

# Experimental Results of Non-Radiative Calibration of a Tower Top Adaptive Array

Justine Mc Cormack, Gerry Corley and Ronan Farrell

*Centre of Telecommunications Value Chain Research,  
Institute of Microelectronics and Wireless Systems,  
National University of Ireland, Maynooth,  
Co. Kildare, Ireland.*

*jmccormack@eeng.nuim.ie  
gcorley@eeng.nuim.ie  
rfarrell@eeng.nuim.ie*

**Abstract**— The need for calibration in antenna arrays is a persistent challenge and is one of the impediments to their widespread integration into communication infrastructures. The choice of antenna array structure dictates the means by which calibration can be achieved. The antenna structure used here is a distributed source array with an interconnected measurement structure for calibration. This non-radiative approach was taken to remove the need for external calibration sources, or computationally expensive modelling. This approach requires a calibration algorithm to utilise the measurement structure to get the best results. This paper will present a set of three such calibration algorithms used on an experimental setup to show the effectiveness of such calibration.

## I. INTRODUCTION

Antenna arrays provide a means of optimizing the radio links, by providing an increase in capacity, interference nulling and direction finding of users [1], [2]. These advantages assume that the elements of the array are amplitude and phase matched, or the differences to be known. However in a practical implementation, these amplitude and phase relationships are altered by finite manufacturing tolerances, path length mismatch, component aging, thermal effects, tower effects, element position variations and mutual coupling [3-16]. These imbalances are in some cases dynamic and angle of arrival dependent [17]. The dynamic nature of the array errors means that once off calibration, such as that done directly after manufacturing, is not sufficient to maintain performance.

These amplitude and phase imbalances or errors have an impact on the radiation pattern, which is to alter their beam pointing direction, sidelobe level, half power beamwidth and null depth [18]. There is a roughly linear relationship between amplitude and phase errors and beam pointing direction [19], the beamwidth [15], sidelobe levels [3], [20] and null depths of the radiation pattern.

The effect on the radiation patterns due to the imbalances in the amplitude and phase relationships make it very important to select an appropriate synchronisation or calibration method. There have been several different approaches taken in the past, such as creating fixed paths to each element of the array [5], [21], using calibration algorithms [11], which can be based

upon array modelling [4], or measurements which in turn can be internal or external [5].

This paper presents a non-radiative approach to calibration. This choice was made because it offers a solution which does not require external sources, machined paths or extensive modelling of the array. The reasons for avoiding these approaches are that as the environment changes so will the performance of the array. Therefore dynamic calibration will be required. The non-radiative approach uses a distributed transceiver system which has an interleaved measurement structure for tower top implementation.

This paper is organised into six sections, the first of which presents the non-radiative measurement structure. This is followed by a section presenting the calibration algorithms that will be implemented on the system. The experimental structure is presented in the next section. The results are then presented and discussed.

## II. NON-RADIATIVE TOWER TOP STRUCTURE

The non-radiative tower top structure is a distributed transceiver array, which consists of low power distributed transceiver elements, interwoven with reference elements, as is shown in fig 1. The non-radiative calibration is achieved by means of a measurement path for each array element. These measurement or calibration paths consist of the transceiver element, a directional coupler [22], and a

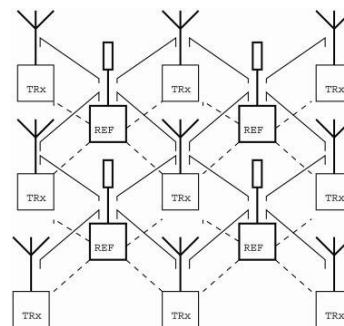

Figure 1: Distributed Transceiver System, with built in Calibration Infrastructure.

reference element, where feedback is provided digitally, as seen in fig 2. The advantage of this non-radiative calibration infrastructure is that it removes the need to have an external source or calibration system, so that calibration can be performed dynamically.

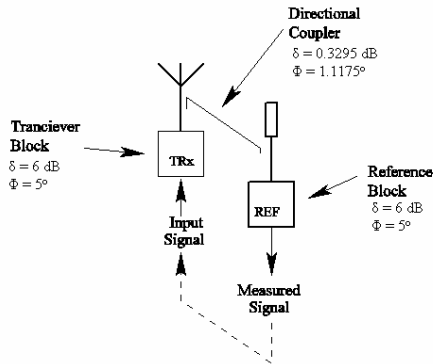

Figure 2: Calibration Path for an Antenna Element

This system provides a set of interconnecting reference elements, these reference elements provide at least one calibration path for each of the elements of the array, and in some cases, multiple calibration paths are provided. Each of these calibration paths consists of the transceiver element, the interconnecting directional coupler path, the reference element and the digital feed back provided in the baseband. This is more clearly seen in fig 2. Calibration algorithms utilise this unique structure to calibrate the array.

Another advantage of using this measurement structure is that it provides a rigid structure to the antenna array. This has the effect of removing element position errors from the calibration problem.

### III. CALIBRATION ALGORITHMS

This paper compares three previously presented calibration algorithms with varying calibration accuracies, so that their effectiveness can be compared. The three calibration algorithms are a top left reference calibration algorithm, middle reference calibration algorithm [23] and a dual path calibration algorithm [24].

The top left reference calibration algorithm is a comparison only algorithm. It selects a reference antenna element in the top left corner of the array. Then performs comparisons with the elements connected to the reference antenna element. The calibration progresses through the array using these one to one comparisons. It has an RMS standard deviation of 0.6361 dB and 2.1418° for a 5 by 5 planar array, calculated over 10,000 simulated array calibrations.

The middle reference calibration algorithm is a comparison only algorithm. It selects a reference antenna element in the middle of the array, and performs the same calibration process as top left calibration algorithm. It has an RMS standard deviation of 0.5472 dB and 1.8548° for a 5 by 5 planar array, calculated over 10,000 simulated array calibrations.

The dual path algorithm is another comparison based calibration algorithm, but it takes two paths to each element.

The calibration is set up the same way as the middle reference algorithm. Instead of using only one to one comparisons, the algorithm takes two paths of identical length to each element of the array from the reference antenna. These two paths are averaged to reduce the effect of coupler mismatch errors, to give overall consistency. It has an RMS standard deviation of 0.4716 dB and 1.6036° for a 5 by 5 planar array, calculated over 10,000 simulated array calibrations.

### IV. EXPERIMENTAL SETUP

The experimental setup presented uses a 2 by 4 array, which is shown in fig. 3. The experimental setup is a representative structure as apposed to a full transceiver implementation. The transceiver elements are represented by voltage controlled attenuators (Mini-Circuits RVA-3000) and phase shifters (Mini-Circuits JSPHS-2484) to emulate the variations between each of the array elements. For the purposes of measurement, the antenna elements have been replaced by connections to a high speed scope (Agilent infiniium 54853A DSO 2.5GHz). The structure is fed by a signal generator, which supplies a single 2.46GHz signal. This signal is split into 8 signals. Each of these signals flow into each elements voltage controlled attenuators and phase shifters. These attenuators and phase shifters are set so that each path has a different amplitude and phase variation, which can be seen in fig. 4.

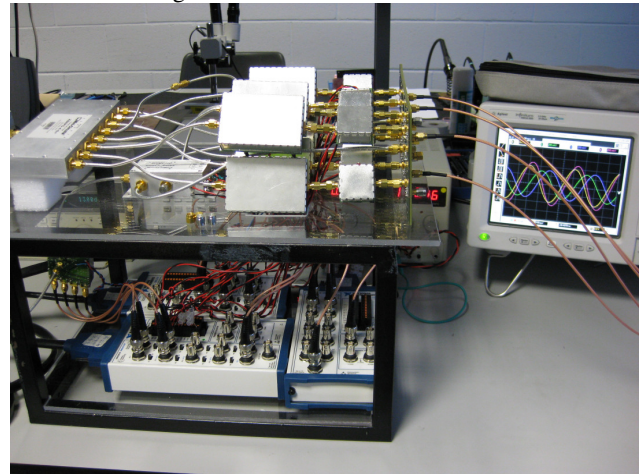

Figure 3: A photo of the 2 by 4 experimental array, where the antennas are replaced by a high speed scope.

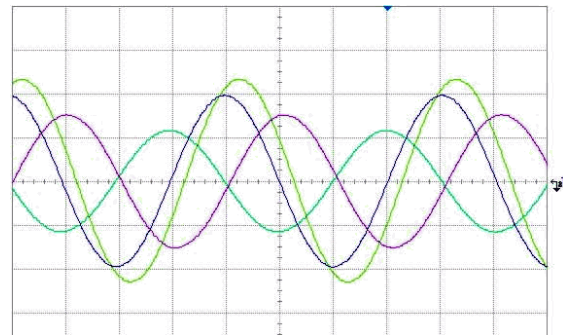

Figure 4: High Speed Scope Display of Uncalibrated Output Signals.

The calibration algorithms are implemented using Labview (National Instruments) via digital feedback provided by a set of two National Instruments PCI cards (6723 and 6251) and three breakout boxes (BNC-2110).

### V. EXPERIMENTAL RESULTS

As mentioned above, the top left reference calibration algorithm, the middle reference calibration algorithm and the dual path calibration algorithm need to be implemented upon the non-radiative measurement structure to achieve calibration. The experimental results from these calibration algorithms are presented in terms of the simulation predictions for a 2 by 4 array. The simulated probability density function (PDF) of the algorithm is determined from 1000 non-ideal arrays calibrated by the calibration algorithm under investigation. The non-ideal arrays are generated with randomly generated component variances, which are based upon the mean value ( $\mu$ ) and the standard deviation ( $\sigma$ ) of the component value from this mean, these parameters are defined in table 1. The PDF of the experimental data is presented to highlight the performance of the array. This PDF has been centred at zero to by removing common offsets, for a clearer comparison of results.

TABLE I  
COMPONENT IMBALANCES

Component (i,j)	$\mu_{(i,j)A}$	$\sigma_{(i,j)A}$	$\mu_{(i,j)\Phi}$	$\sigma_{(i,j)\Phi}$
Tx S21	50 dB	3 dB	10°	5°
Ref S21	60 dB	6 dB	85°	5°
Coupler S21	20.3295dB	0.3295dB	90.197°	1.1175°

First we will consider the top left reference calibration algorithm. The sinusoidal waveforms measured by the high speed scope are presented in fig. 5, when compared to the uncalibrated signals shown in fig. 4; it shows the effectiveness of the calibration. However for a more detailed analysis the experimental results are compared to the simulated performance of the calibration algorithm. This comparison of the simulated probability density of the calibrated errors with the experimental results is shown in Fig. 6 and 7. The performance achieves the criterion of less than 1dB. However, the phase criterion of less than 5° has been achieved for all but two of the phase values, 5.13° and 5.7°.

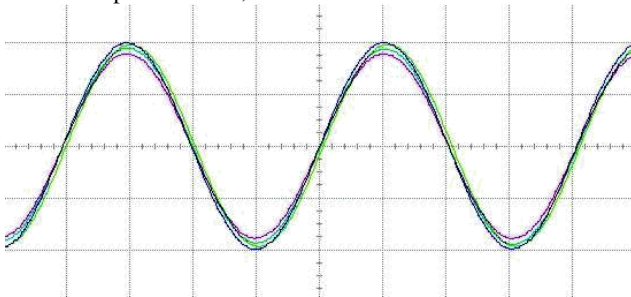

Figure 5: High Speed Scope Display of top left reference calibrated Output Signals.

Secondly, the sinusoidal waveforms measured by the high speed scope are presented in fig. 8, when compared to the

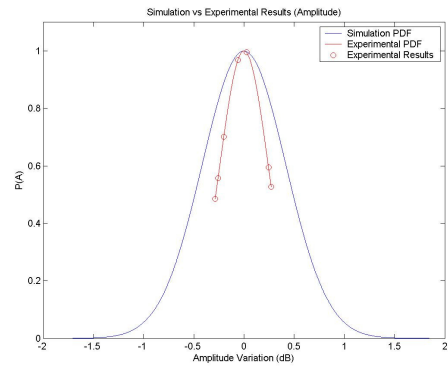

Figure 6: The Amplitude Simulation Results vs. Amplitude Experimental Results for the Top Left Reference Calibration Algorithm for a 2 by 4 array.

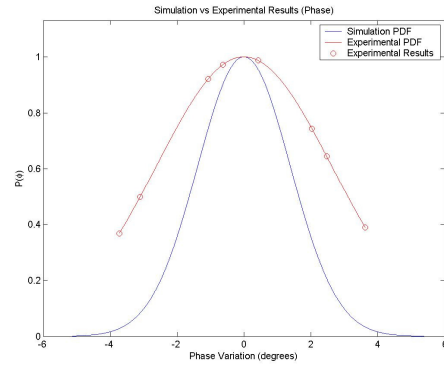

Figure 7: The Phase Simulation Results vs. Phase Experimental Results for the Top Left Reference Calibration Algorithm for a 2 by 4 array.

uncalibrated signals shown in fig. 4; it shows the effectiveness of the calibration. As before, a more detailed analysis of the experimental results is achieved when compared to the simulated performance of the calibration algorithm, which is shown in Fig. 9 and 10. The performance achieves the criterion of less than 1dB. It must be noted that the amplitude values from the experimental results have a narrower distribution than the top left reference calibration experimental results. However, the phase criterion of less than 5° has been achieved for all but one of the phase values 5.7°.

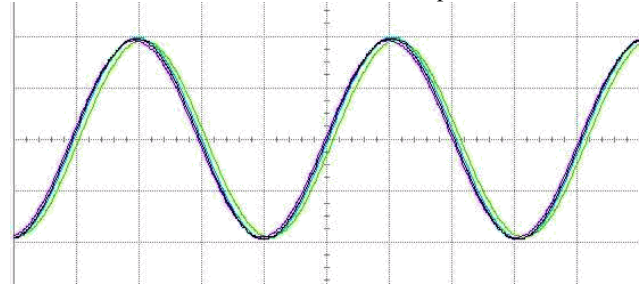

Figure 8: High Speed Scope Display of Middle Reference Calibrated Output Signals.

Finally, the sinusoidal waveforms measured by the high speed scope are presented in fig. 11. When compared to the uncalibrated signals shown in fig. 4; it shows the effectiveness

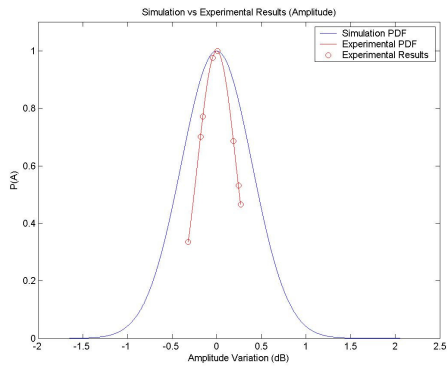

Figure 9: The Amplitude Simulation Results vs. Amplitude Experimental Results for the Middle Reference Calibration Algorithm for a 2 by 4 array.

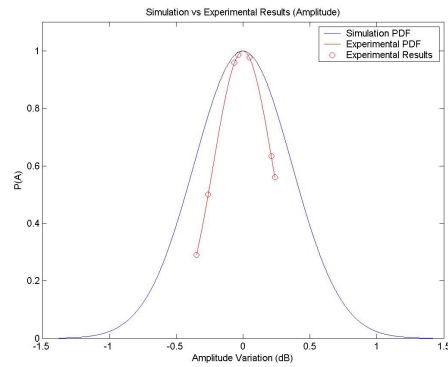

Figure 12: The Amplitude Simulation Results vs. Amplitude Experimental Results for the Dual Path Calibration Algorithm for a 2 by 4 array.

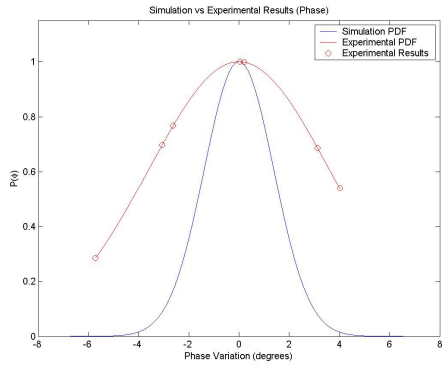

Figure 10: The Phase Simulation Results vs. Phase Experimental Results for the Middle Reference Calibration Algorithm for a 2 by 4 array.

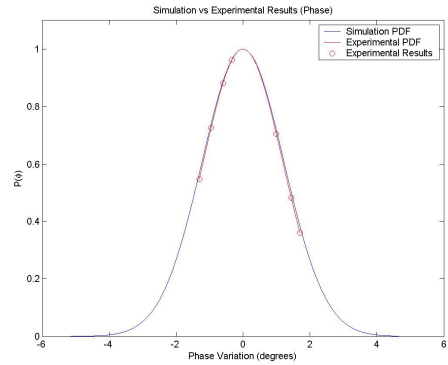

Figure 13: The Phase Simulation Results vs. Phase Experimental Results for the Dual Path Calibration Algorithm for a 2 by 4 array.

of the calibration. The comparison of the simulated performance of the calibration algorithm with that of the experimental results gives a better comparison and is shown in Fig. 12 and 13. The performance achieves the criterion of less than  $1dB$ . It must be noted that the amplitude values from the experimental results have a narrower distribution than that of the middle reference calibration experimental results, except for a single outlier. The phase criterion of less than  $5^\circ$  has been achieved for all element of the array, which surpasses either of the previous two algorithms.

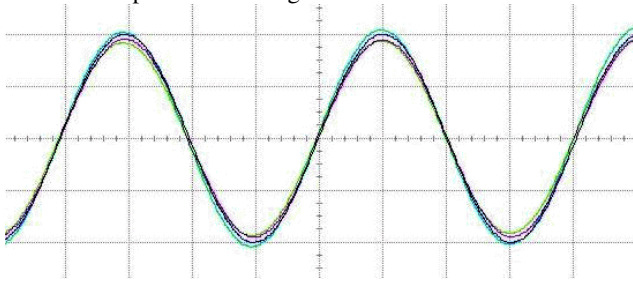

Figure 11: High Speed Scope Display of Dual Path Calibrated Output Signals.

## VI. DISCUSSION

The experimental results are consistent with the predicted performance from the calibration algorithms simulations. The

performance can be seen to gradually improve from the first calibration algorithm considered, top left reference calibration algorithm, to the final calibration algorithm that is considered here, dual path calibration algorithm. The reason for this gradual performance improvement is based on the fact that each of these algorithms is comparison based. The reason for this choice of calibration base technique is due to the fact that this non-radiative calibration structure is based on the sensor elements interleaved in the array. These sensor elements are not ideal and therefore will introduce calibration errors themselves. The effect of these errors can be reduced by using comparisons at each sensor elements; this prevents the sensor element errors propagating through the array.

The performance of the middle reference calibration algorithm is predicted to be better than the top left reference calibration algorithm as the reference antenna element is moved from the top left corner to the middle of the array, reducing the overall path length. The experimental data agrees with this prediction, the distribution of the values is wider for top left reference algorithm, and there are two phase outliers. There is however not a large improvement in our experimental setup array (2 by 4) as the reference antenna element in only moves in by one element due to the small size of the array.

The performance of the dual path calibration algorithm is predicted to have improved performance over the top left

reference calibration algorithm and the middle reference algorithm. The experimental results hold up this prediction, particularly in the phase results, as the dual path algorithm has met the less than  $5^\circ$  criterion, when neither of the other two algorithms have. This improvement is due to the use of two paths to each element of the array instead of one. These comparisons are taken along paths of equal length from the reference antenna element to the calibrated element. The length criterion is used so that the number of coupler errors included in the comparisons is the same, so that there is not an increase in calibration errors from comparing two different path lengths. The two comparisons taken for each element are averaged. The reason for this averaging is to reduce the impact of coupler variations on the calibration performance, which has not been removed by the comparisons.

## VII. CONCLUSIONS

This paper has presented a non-radiative calibration structure for an antenna array. This structure provides a rigid measurement structure which eliminates the position errors from the calibration problem as well as providing multiple measurement paths for all array elements except for the corner elements. These measurement paths are utilized by calibration algorithms. Three such calibration algorithms were implemented on a representative experimental setup, top left reference, middle reference and dual path calibration algorithms. These algorithms are all comparison based algorithms, to reduce the propagation of errors. The experimental performances of these algorithms were compared to Matlab simulations to show the effectiveness of this non-radiative calibration performance. The algorithms have shown their progressive performance improvement, so that the criterion of amplitude variance of less than 1 dB and phase variance of less than  $5^\circ$ .

## ACKNOWLEDGMENT

This material is based upon work supported by Science Foundation Ireland under Grant No. 03/CE3/I405 as part of the Centre for Telecommunications Value-Chain Research (CTVR) at the National University of Ireland, Maynooth.

## REFERENCES

- [1] B. Lindmark, S. Lundgren, J. R. Sanford, and C. Beckman, "Dual-polarized array for signal-processing applications in wireless communications," *Antennas and Propagation, IEEE Transactions on*, vol. 46, pp. 758-763, 1998.
- [2] C. Passmann, F. Hickel, and T. Wixforth, "Investigation of a calibration concept for optimum performance of adaptive antenna systems," presented at Vehicular Technology Conference, 1998. VTC 98. 48th IEEE, 1998.
- [3] R. Elliott, "Mechanical and electrical tolerances for two-dimensional scanning antenna arrays," *Antennas and Propagation, IRE Transactions on*, vol. 6, pp. 114-120, 1958.
- [4] C. M. S. See, "A method for array calibration in parametric sensor array processing," presented at Singapore ICCS '94. Conference Proceedings, 1994.
- [5] K. R. Dandekar, L. Hao, and X. Guanghan, "Smart antenna array calibration procedure including amplitude and phase mismatch and

- mutual coupling effects," presented at Personal Wireless Communications, 2000 IEEE International Conference on, 2000.
- [6] W. H. Von Aulock, "Properties of Phased Arrays," *Proceedings of the IRE*, vol. 48, pp. 1715-1727, 1960.
- [7] K. Yoon-Won and D. Pozar, "Correction of error in reduced sidelobe synthesis due to mutual coupling," *Antennas and Propagation, IEEE Transactions on*, vol. 33, pp. 1025-1028, 1985.
- [8] P. S. Carter, "Circuit Relations in Radiating Systems and Applications to Antenna Problems," *Proceedings of the Institute of Radio Engineers*, vol. 20, pp. 1004 - 1041, 1932.
- [9] B. Friedlander and A. J. Weiss, "Direction finding in the presence of mutual coupling," *Antennas and Propagation, IEEE Transactions on*, vol. 39, pp. 273-284, 1991.
- [10] C. M. S. See, "Sensor array calibration in the presence of mutual coupling and unknown sensor gains and phases," *Electronics Letters*, vol. 30, pp. 373-374, 1994.
- [11] N. Boon Chong and S. Chong Meng Samson, "Sensor-array calibration using a maximum-likelihood approach," *Antennas and Propagation, IEEE Transactions on*, vol. 44, pp. 827-835, 1996.
- [12] A. L. Swindlehurst and T. Kailath, "A performance analysis of subspace-based methods in the presence of model errors. I. The MUSIC algorithm," *Signal Processing, IEEE Transactions on*, vol. 40, pp. 1758-1774, 1992.
- [13] W. S. Youn and C. K. Un, "Eigenstructure method for robust array processing," *Electronics Letters*, vol. 26, pp. 678-680, 1990.
- [14] R. Mailloux, "Array grating lobes due to periodic phase, amplitude, and time delay quantization," *Antennas and Propagation, IEEE Transactions on*, vol. 32, pp. 1364-1368, 1984.
- [15] N. Jablon, "Effect of element errors on half-power beamwidth of the Capon adaptive beamformer," *Circuits and Systems, IEEE Transactions on*, vol. 34, pp. 743-752, 1987.
- [16] W. Wasyliwskij, "Mutual coupling effects in semi-infinite arrays," *Antennas and Propagation, IEEE Transactions on*, vol. 21, pp. 277-285, 1973.
- [17] C. Roller and W. Wasyliwskij, "Effects of mutual coupling on super-resolution DF in linear arrays," presented at Acoustics, Speech, and Signal Processing, 1992. ICASSP-92., 1992 IEEE International Conference on, 1992.
- [18] J. K. Hsiao, "Design of error tolerance of a phased array," *Electronics Letters*, vol. 21, pp. 834-836, 1985.
- [19] K. Carver, W. Cooper, and W. Stutzman, "Beam-pointing errors of planar-phased arrays," *Antennas and Propagation, IEEE Transactions on*, vol. 21, pp. 199-202, 1973.
- [20] M. Smith and Y. Guo, "A comparison of methods for randomizing phase quantization errors in phased arrays," *Antennas and Propagation, IEEE Transactions on*, vol. 31, pp. 821-828, 1983.
- [21] J. Andersen and H. Rasmussen, "Decoupling and descattering networks for antennas," *Antennas and Propagation, IEEE Transactions on*, vol. 24, pp. 841-846, 1976.
- [22] T. S. Cooper, G. Baldwin, and R. Farrell, "Six-port precision directional coupler," *Electronics Letters*, vol. 42, pp. 1232-1233, 2006.
- [23] J. McCormack, T. Cooper, and R. Farrell, "Tower-Top Antenna Array Calibration Scheme for Next Generation Networks," *EURASIP Journal on Wireless Communications and Networking*, vol. 2007, pp. 12, 2007.
- [24] J. McCormack, T. Cooper, and R. Farrell, "A Multi-Path Algorithmic Approach to Phased Array Calibration," presented at Antennas and Propagation, 2007. EuCAP 2007. The Second European Conference on, 2007.