

Molecular and Epidemiological Studies of
Trichoderma aggressivum f. *europaeum*

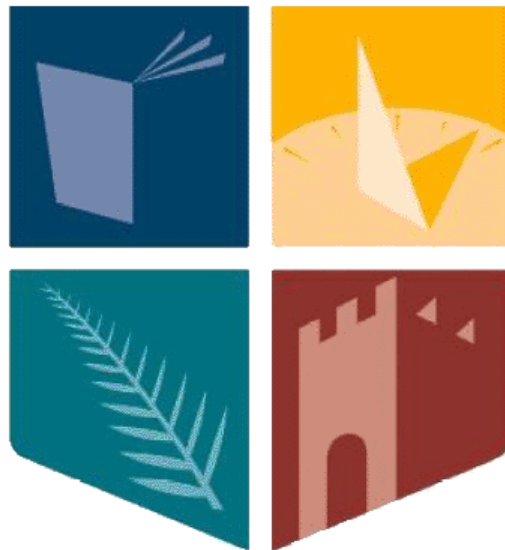

Ollscoil na hÉireann Má Nuad

Matthew O'Brien

Thesis submitted for the degree of doctor of Philosophy in the National
University of Ireland, Maynooth

Supervisors:

Dr. Kevin Kavanagh

Dr. Helen M. Grogan

Head of Department:

Prof. Paul Moynagh

October 2012

CONTENTS

Table of Contents	i
Abstract	vii
Presentations and Publications	ix
Acknowledgements	xi
Declaration	xii
List of Figures	xiii
List of Tables	xvi
List of Abbreviations	xvii
1. <i>Introduction</i>	1
1.1 Kingdom: Fungi	1
1.2 Genus: <i>Trichoderma</i>	2
1.2.1 Anamorphs and Teleomorphs	7
1.2.2 Taxonomy of the <i>Trichoderma harzianum</i> group	7
1.3 <i>Trichoderma aggressivum</i>	8
1.3.1 Early identification	10
1.3.2 Species assignment	10
1.3.3 Cultural and morphological characteristics	14
1.4 Cultivation of <i>Agaricus bisporus</i>	15
1.4.1 Mushroom cultivation systems	16
1.4.2 The Bulk Phase III system	22
1.5 <i>Trichoderma aggressivum</i> in the mushroom industry	23
1.5.1 Symptoms and identification	23
1.5.2 Impact on crops	26
1.5.3 Mechanism of action	26
1.5.4 Epidemiology and spread	31
1.5.5 Points of entry	32

1.5.6	Treatment and control	34
1.6	Aims and Objectives of this Study	35
2.	<i>Materials and Methods</i>	36
2.1	Fungal cell culture	36
2.1.1	Culture media	36
2.1.2	Sterile water	38
2.1.3	Strain maintenance and reference isolates	38
2.1.4	Long term strain storage	38
2.1.5	Liquid culture of <i>Trichoderma</i> isolates	39
2.1.6	Liquid culture of <i>Trichoderma aggressivum</i> with <i>Agaricus bisporus</i> tissue and Bulk Phase III mushroom substrate	40
2.1.7	Colony counting methods	40
2.1.8	Culture waste disposal	42
2.2	Proteomic reagents	42
2.2.1	Protein extraction buffer	42
2.2.2	10X sample buffer	42
2.2.3	10 % w/v APS solution	43
2.2.4	10 % w/v SDS solution	43
2.2.5	SDS-PAGE running buffer	43
2.2.6	Iso-electric focusing (IEF) buffer	43
2.2.7	IEF equilibration buffer	43
2.2.8	Polyacrylamide gels	44
2.2.9	Agarose sealing solution	44
2.2.10	Staining solutions	45
2.3	Proteomic methods	45
2.3.1	Cellular protein extraction	45
2.3.2	Protein quantification by Bradford assay	46
2.3.3	Acetone precipitation of proteins	46
2.3.4	2-Dimensional SDS-PAGE	46
2.3.5	Image acquisition and analysis	48
2.4	Mass spectrometry	48
2.4.1	Reagents	48

2.4.2	Sample preparation for mass spectrometry	49
2.4.3	LC-MS analysis of trypsin digested proteins	50
2.5	Mushroom cropping experiments	50
2.5.1	Statistical analysis	51
2.6	Molecular biology methods	51
2.6.1	DNA extraction methods	51
2.6.2	Cell homogenisation buffer	53
2.6.3	TAE buffer	53
2.6.4	Determination of DNA concentration by UV absorbance	54
2.6.5	DNA gel electrophoresis and visualisation	54
2.6.6	Endpoint PCR using Sigma Accutaq	54
2.6.7	Endpoint PCR using Bioline 2X Mastermix	55
2.6.8	Quantitative real-time PCR (qPCR)	55
2.6.9	Primers	56
2.7	HPLC	57
2.7.1	HPLC extraction buffer	57
2.7.2	HPLC Buffer A	57
2.7.3	HPLC Buffer B	57
2.7.4	Organic extraction of fungal metabolites for analysis by HPLC	58
2.7.5	Reverse phase HPLC analysis of fungal metabolites	58
2.7.6	Comparison of metabolite profiles	60
3.	<i>Cellular proteomics of Trichoderma aggressivum</i>	61
3.1	Introduction	61
3.2	2-D electrophoretic profile of <i>Trichoderma aggressivum</i> across a pH 4-7 range	63
3.3	Identification of protein homologs in <i>Trichoderma aggressivum</i> strain CBS 433.95 by LC/MS analysis of tryptic digests	63
3.4	Identification of protein homologs in <i>Trichoderma aggressivum</i> strain CBS 100526 by LC/MS analysis of tryptic digests	72

3.5	2-D electrophoretic analysis of <i>Trichoderma aggressivum</i> strain CBS 100526 grown in the presence of mushroom substrate and mushroom tissue.	80
3.6	Differential protein expression in <i>Trichoderma aggressivum</i> strain CBS 100526 grown in the presence of Bulk Phase III mushroom substrate and mushroom tissue.	82
3.7	Discussion	89
3.7.1	Protein homologies	89
3.7.2	Differentially expressed proteins and the virulence of <i>Trichoderma aggressivum</i>	94
4.	<i>Trichoderma aggressivum</i> in Bulk Phase III mushroom substrate	99
4.1	Introduction	99
4.1.1	Epidemiology of <i>Trichoderma aggressivum</i> in Bulk Phase III mushroom substrate	99
4.1.2	Methods for the detection of <i>Trichoderma aggressivum</i> in mushroom substrate	100
4.1.3	Aim of the study	102
4.2	Experimental	103
4.2.1	Fungal strains	103
4.2.2	Preparation of inoculum	103
4.2.3	Infection of Bulk Phase III substrate	105
4.2.4	Cropping experiment 1	106
4.2.5	Cropping experiment 2	106
4.2.6	Cropping experiment 3	107
4.2.7	Quantification and detection of <i>Trichoderma aggressivum</i> infection in inoculated Bulk Phase III mushroom substrate	107
4.3	Results	108
4.3.1	Cropping experiment 1	108
4.3.2	Cropping experiment 2	109
4.3.3	Cropping experiment 3	110

4.3.4	Comparison of microbiological and molecular methods for quantifying <i>Trichoderma aggressivum</i> infection level in Bulk Phase III mushroom substrate	112
4.4	Discussion	115
4.4.1	The effect of substrate infection rate, supplementation and mixing on mushroom yield in <i>Trichoderma aggressivum</i> infected crops	115
4.4.2	Detection of <i>Trichoderma aggressivum</i> in Bulk Phase III mushroom substrate	116
5.	<i>Interspecific Molecular and Chemical Variation in Trichoderma Isolates</i>	120
5.1	Identification of fungi using PCR	120
5.1.1	Differentiation of fungi based on secondary metabolite profiles	121
5.2	Evaluation of DNA extraction methods for the purification of PCR amplifiable DNA from <i>Trichoderma</i> cultures	123
5.2.1	Manual DNA extraction by salt precipitation	123
5.2.2	DNA extraction with Qiagen Plant DNeasy spin kit (®)	124
5.2.3	DNA extraction with Sigma Plant Genomic DNA extraction kit (®)	125
5.2.4	DNA extraction with Promega Wizard Magnetic Food DNA extraction kit	126
5.2.5	DNA extraction with Chemagen Chemagic Food DNA extraction kit	127
5.2.6	DNA extraction with ZR Fungal/ Bacterial DNA extraction kit	128
5.2.7	Summary	129
5.3	Sequence analysis and novel selective primers	130
5.3.1	Primer efficiency and standard curves	133
5.3.2	Melt curve analysis	136
5.3.3	Comparison of novel and existing primers for differentiating <i>Trichoderma</i> isolates	139
5.4	Differentiation of <i>Trichoderma</i> isolates using HPLC metabolite profiling	142

5.4.1	Optimisation of elution protocol	142
5.4.2	Metabolite profiles of <i>Trichoderma</i> isolates grown on dif- ferent media	142
5.4.3	Comparison of <i>Trichoderma</i> metabolite profiles to a <i>Tri- choderma aggressivum</i> reference profile	145
5.5	Discussion	147
5.5.1	DNA extraction methods	147
5.5.2	Identification of <i>Trichoderma aggressivum</i> by real-time PCR	149
5.5.3	HPLC metabolite profiling	151
6.	<i>General Discussion</i>	153
	<i>Bibliography</i>	160

ABSTRACT

Trichoderma aggressivum is the causal agent of severe green mould disease in the cultivated mushroom *Agaricus bisporus* (Samuels *et al.*, 2002). This fungus was first isolated in Ireland in 1987 during an epidemic of green mould disease and has subsequently been isolated from mushroom farms across Europe and North America (Largeteau *et al.*, 2010). There are two subspecies *T. aggressivum* f. *aggressivum* and *T. aggressivum* f. *europaeum* which are found in North America and Europe respectively, the latter is the subject of this work.

The purpose of this study was to investigate the interaction of *T. aggressivum* with *A. bisporus* and mushroom substrate, to study the epidemiology of *T. aggressivum* in Bulk Phase III mushroom systems and to develop methods for the detection of *T. aggressivum*. A separate results chapter is presented for each area of research.

T. aggressivum has specific attributes which allow it to grow better in mushroom substrate than other *Trichoderma* species, resist inhibition by *A. bisporus* metabolites and ultimately cause more severe reductions in mushroom yield (Largeteau *et al.*, 2000b; Mumpuni *et al.*, 1998). A proteomic method was employed to study the effect of mushroom substrate and *A. bisporus* tissue on *T. aggressivum in vitro*. Proteins involved in the oxidative stress response were up-regulated in *T. aggressivum* in both treatments. *In vivo* the production of oxidative stress response proteins may be part of the ability of *T. aggressivum* to resist inhibition by the microbial population of mushroom substrate and by *A. bisporus*, thereby colonising the substrate and reducing mushroom yields (Largeteau *et al.*, 2000b; Savoie *et al.*, 2001a; Williams *et al.*, 2003a).

Much of the research on the epidemiology of *T. aggressivum* in mushroom production was performed in *in situ* spawn run systems. The Bulk Phase III system has become more common in Europe in recent years but there is little

information about *T. aggressivum* in this system. Cropping experiments were carried out to investigate the epidemiology of *T. aggressivum* in Bulk Phase III with particular emphasis on the effect of bulk handling of spawn-run substrate on infection. Infection of Bulk Phase III substrate during bulk handling was shown to be possible. The severity of infection depended on *T. aggressivum* load and on the amount of mixing performed during bulk handling.

Identification of *T. aggressivum* can be problematic due to morphological similarities with *Trichoderma harzianum* and other *Trichoderma* species found on mushroom farms (Seaby, 1996a). The most common method for differentiating *T. aggressivum* from other species is the use of PCR (Chen *et al.*, 1999a) with selective primers. In this study a real-time PCR method for identification of *T. aggressivum* was developed, novel selective primers were designed and compared to existing *T. aggressivum* selective primers and HPLC analysis of secondary metabolite profiles was assessed as an alternative method for the identification of *T. aggressivum*.

Keywords: *Agaricus bisporus*, Bulk Phase III, green mould disease, proteomics, real-time PCR, *Trichoderma aggressivum*

PRESENTATIONS AND PUBLICATIONS

- **O' Brien, M.**, Grogan H. and Kavanagh K. 2010. Epidemiology and detection of *Trichoderma aggressivum* in bulk phase 3 mushroom systems. Biology Departmental Research Day, National University of Ireland Maynooth. Oral presentation.
- **O' Brien, M.**, Grogan H. and Kavanagh K. 2011. Protein profiling of *Trichoderma aggressivum* f. *europaeum*, fungal pathogen of the button mushroom. Society for General Microbiology Spring Meeting, Queens University Belfast. Oral presentation.
- Grogan, H. and Noble, R. and Dobrovin-Pennington A, and Lane, C. and Nixon, T. and **O'Brien, M.** and Gaze, R. 2011. *Trichoderma aggressivum* f. *europaeum* (Th2): Epidemiology in bulk Phase III systems. Horticultural Development Company Report M50. Technical report.
- **O' Brien, M.**, Grogan H. and Kavanagh K. 2011. Molecular and epidemiological studies of *Trichoderma aggressivum*. Biology Departmental Research Day, National University of Ireland Maynooth. Oral presentation.
- **O' Brien, M.**, Grogan H. and Kavanagh K. 2011 Pathogenesis of *Trichoderma aggressivum*. Irish Fungal Society Meeting, Trinity College, Dublin. Oral presentation.
- **O' Brien, M.**, Kavanagh K and Grogan H. 2011. Characterisation of *Trichoderma aggressivum* infection in Bulk Phase III mushroom systems. 7th International Conference on Mushroom Biology and Mushroom Products, Arcachon, France. Poster presentation, conference proceedings p 225.

- **O' Brien, M.**, Kavanagh K and Grogan H. 2011. Green mould in bulk Phase III. Irish Mushroom Conference and Trade Show, Monaghan. Poster presentation, winner of best poster award.
- Grogan, H., **O' Brien, M.**, Kavanagh, K., Dobrovin-Pennington, A., Nixon, T. and Lane, C. 2012. Epidemiology of *Trichoderma aggressivum* in Bulk Phase III compost for *Agaricus bisporus* production. Proceedings of the 18th Congress of the International Society for Mushroom Science p 336-342. Conference proceedings.

ADMHÁLACHA - ACKNOWLEDGEMENTS

Ar dtús ba mhaith liom buíochas a ghabháil le Helen Grogan agus Kevin Kavanagh as ucht stiúir agus comhairle a thabhart dom le trí bliana anuas. Tá mé faoi chomaion agaibh.

Chabhraigh Brian McGuinness, Pat Rafferty agus Eugene O' Gorman liom agus mé ag sathrú beacán, tá mé an bhuíoch as sin. Thug mic léin foirgnimh Challan ar fad cabhair dom le turgnaimh agus níos mó, is dócha go dtuigeann sibh féin an tábhacht a baineann le sin.

Is iad na cairde a bhí liom le linn na hoibre seo a rinne éasca é. Gach éinne a chonaigh liom i dTeach Maigh Eo, beidh cuimhne agam oraibh le fada an lá. A fhoireann cic-dornálaíochta, bhí sibh mar leigheas ar mo chuid frustrachais. Mo seanchairde, thug mé neamhaird oraibh ach rinne sibh a mhalairt. Agus Muireann, le fáth atá follasach ann féin.

Ar deireadh, caithfidh mé an buíochas is mó a ghabháil le mo chlann. Murach sibhse ní bhéinn anseo chor ar bith. Tá grá agam daoibh uilig.

-Matt

DECLARATION

This thesis has not been submitted in whole or in part to this or any other university for any degree and is the original work of the author except where otherwise stated.

Signature:-----

Date:-----

LIST OF FIGURES

1.1	Genome sequencing projects for <i>Trichoderma</i> species. Accessed from GenBank September 2012.	6
1.2	Phylogenetic tree of <i>Trichoderma harzianum sensu lato</i> based on rDNA sequencing and RFLP analysis.	9
1.3	Phylogenetic relationship of mushroom associated <i>Trichoderma harzianum</i> biotypes.	13
1.4	Conidiophores of <i>Trichoderma aggressivum</i> f. <i>europaeum</i> (Left) and <i>Trichoderma aggressivum</i> f. <i>aggressivum</i> (Right).	14
1.5	Annual output of top 10 mushroom producing nations from 1990-2010	15
1.6	Outline of mushroom production process.	19
1.7	Symptoms of <i>Trichoderma aggressivum</i> infection at different stages of the cropping cycle	25
1.8	Spent mushroom substrate colonised by <i>Trichoderma aggressivum</i> and <i>Agaricus bisporus</i>	29
2.1	Example of results of most probable number assay	41
2.2	Example of results of a direct plating assay.	42
2.3	HPLC gradient profiles.	59
3.1	2-D electrophoretic profile of <i>Trichoderma aggressivum</i> strain CBS 433.95.	64
3.2	2-D electrophoretic profile of <i>Trichoderma aggressivum</i> strain CBS 100526.	65
3.3	Protein spots analysed by LC/MS from <i>Trichoderma aggressivum</i> strain CBS 433.95.	67

3.4	Protein spots analysed by LC/MS from <i>Trichoderma aggressivum</i> strain CBS 100526.	74
3.5	2-Dimensional protein profile of <i>Trichoderma aggressivum</i> strain CBS 100526 grown in different media.	81
3.6	Differentially expressed protein in <i>Trichoderma aggressivum</i> strain CBS 100526 with exposure to <i>Agaricus bisporus</i> tissue and/or Bulk Phase III mushroom substrate.	83
3.7	Relative expression levels of differentially expressed proteins in <i>Trichoderma aggressivum</i> strain CBS 100526 when exposed to <i>Agaricus bisporus</i> tissue and Bulk Phase III mushroom substrate.	90
4.1	Production of <i>Trichoderma aggressivum</i> infected Phase 3 compost.	104
4.2	Effect of infection level and supplement on mushroom yield - experiment 1.	108
4.3	Effect of infection rate and supplement on mushroom yield - experiment 2.	109
4.4	Effect of infection level and supplement on mushroom yield - experiment 3.	110
4.5	Composite image of mushroom growth - experiment 3	111
5.1	EtBr gel of genomic DNA extracted by Aljanabi & Martinez (1997) method.	123
5.2	DNA extract by Qiagen Plant Genomic method from <i>T. aggressivum</i> mycelium (A) and colonised Bulk Phase III mushroom substrate (B).	124
5.3	DNA extract by Sigma Plant Genomic method from <i>T. aggressivum</i> mycelium (A), colonised Bulk Phase III mushroom substrate (B) and PCR product of mushroom substrate extract (C).	125
5.4	DNA extract by Promega Magnetic method from <i>T. aggressivum</i> mycelium (A) and spore suspension (B)	126
5.5	DNA extract by Chemagen Magnetic method from <i>T. aggressivum</i> spore suspension (Left) and colonised Bulk Phase III mushroom substrate (Right).	127

5.6	EtBr gel of Genomic DNA extracted with ZR Fungal/ Bacterial DNA extraction kit	128
5.7	MegaBlast search sequence alignment of genes homologous with <i>T. aggressivum</i> tef1.	131
5.8	Sequences aligning with <i>T. aggressivum</i> tef1 query sequence.	132
5.9	Standard curves of <i>T. aggressivum</i> DNA amplified with novel and existing primers	135
5.10	Melt curve analysis of products from primer standard curves	138
5.11	Reactivity of novel and existing primers with <i>Trichoderma</i> isolates.	141
5.12	HPLC chromatogram of <i>Trichoderma</i> metabolites using standard HPLC Method (Abs 254 nm).	143
5.13	HPLC chromatogram of <i>Trichoderma</i> metabolites using modified HPLC Method (Abs 254 nm).	143
5.14	Reference metabolite profile for <i>Trichoderma aggressivum</i>	146

LIST OF TABLES

2.1	<i>Trichoderma</i> isolates used in this work.	39
2.2	Iso-electric focusing protocol for pH 4-7 IPG strips	47
2.3	Search parameters for Mascot searches	50
2.4	PCR amplification protocol using Sigma AccuTaq	55
2.5	PCR amplification protocol using Bioline Mastermix	55
2.6	Real-time PCR cycling parameters	56
2.7	Primers used in this study	57
2.8	HPLC elution methods.	59
3.1	Proteins displaying homology with LC/MS analysed <i>T. aggressivum</i> strain CBS 433.95 proteins.	68
3.2	Accession number, Mascot score and additional information for proteins analysed from <i>Trichoderma aggressivum</i> strain CBS 433.95.	71
3.3	Proteins displaying homology with LC/MS analysed <i>Trichoderma aggressivum</i> strain CBS 100526 proteins.	75
3.4	Accession number, Mascot score and additional information for proteins analysed from <i>Trichoderma aggressivum</i> strain CBS 100526.	78
3.5	Normalised expression levels and relative fold changes of spots differentially expressed in <i>Trichoderma aggressivum</i> strain CBS 100526 in response to <i>Agaricus bisporus</i> tissue or Bulk Phase III mushroom substrate.	85
3.6	Mascot search results for analysed peptides from differentially expressed <i>Trichoderma aggressivum</i> strain CBS 100526 proteins.	87
4.1	Generalised treatment composition for cropping experiments	105
4.2	Two way ANOVA of mushroom yield - experiment 1.	108
4.3	Two way ANOVA of mushroom yield - experiment 2.	109

4.4	Two way ANOVA of mushroom yield - experiment 3.	110
4.5	Detection of <i>Trichoderma aggressivum</i> in Bulk Phase III mushroom substrate by qPCR, MPN and DPA - experiment 2.	113
4.6	Detection of <i>Trichoderma aggressivum</i> in Bulk Phase III mushroom substrate by qPCR, MPN and DPA - experiment 3.	114
4.7	Correlation analysis of methods used for the detection of <i>T. aggressivum</i>	114
5.1	Nucleotide sequence of <i>tef1</i> gene from <i>T. aggressivum</i> strain CBS 100526	130
5.2	<i>In silico</i> analysis of primer specificity.	134
5.3	Validation of novel and existing primers for identification of <i>T. aggressivum</i> isolates using real-time PCR.	140
5.4	Cophenetic correlation of metabolite profiles from <i>Trichoderma</i> isolates.	144

LIST OF ABBREVIATIONS

Abs	Absorbance
APS	Ammonium persulfate
bp	Base pair
BSA	Bovine serum albumin
°C	Degrees celsius
cfu/g	Colony forming units per gram fresh weight
CHAPS	3-[(3-cholamidopropyl)dimethylammonio]-1-propanesulfonate
cm	Centimeter
Cp	Crossing point
CT	Cycle-threshold
CV	Co-efficient of variability
DMSO	Dimethyl sulfoxide
DNA	Deoxyribonucleic acid
dNTP	Deoxynucleotide 5'-triphosphate
DPA	Direct plating assay
DTT	Dithiothreitol
EDTA	Ethylenediamine tetra-acetic acid
FA	Formic acid
Fig.	Figure
g	Gram
GC	Guanine-cytosine
GC/MS	Gas chromatography-mass spectrometry
HPLC	High performance liquid chromatography
hr	Hour
IAA	Iodoacetamide
IEF	Isoelectric focusing

IPG	Immobilised pH gradient
KCl	Potassium chloride
K ₂ HPO ₄	Di-potassium hydrogen phosphate
kDa	Kilodalton
kg	Kilogram
L	Litres
LC/MS	Liquid chromatography-mass spectrometry
M	Molar
m	Meter
MEA	Malt extract agar
MEAS	Malt extract, streptomycin sulphate agar
min	Minutes
mg	Milligramms
MgSO ₄	Magnesium sulphate
ml	Millilitre
mM	Millimolar
MPN	Most probable number
n/a	Not applicable
nd	No data
ng	Nanogram
nm	nanometer
PAGE	Polyacrylamide gel electrophoresis
PCR	Polymerase chain reaction
pg	Picogram
pI	Isoelectric point
PPE	Personal protective equipment
ppm	Parts per million
qPCR	Quantitative real-time PCR
Q-TOF-MS	Quadrupole time-of-flight mass spectrometry
RAPD	Random amplified polymorphic DNA
rcf	Relative centrifugal force
RFLP	Restriction fragment length polymorphism
rpm	Revolutions per minute

RNA	Ribonucleic acid
rDNA	Ribosomal DNA
rRNA	Ribosomal RNA
sec	Second
SEM	Standard error of mean
SDS	Sodium dodecyl sulfate
sp.	Species (singular)
spp.	Species (plural)
Tab	Table
TAE	Tris acetate buffer
TEMED	N,N,N,N-Tetramethyl-ethane-1,2-diamine
TFA	Trifluoroacetic acid
TLCK	N α -Tosyl-L-lysine chloromethyl ketone hydrochloride
T _m	Melting temperature
UPLC	Ultra performance liquid chromatography
UV	Ultra violet light
V	Volt
v/v	Volume per volume
WMA	Weed mould analysis
w/v	Weight per volume
μ l	Microlitre
μ M	Micromolar

1. INTRODUCTION

1.1 *Kingdom: Fungi*

Fungi are heterotrophic eukaryotes previously classified as plants which were subsequently assigned their own kingdom (Whittaker, 1969) and can be shown to be more closely related to animals in evolutionary terms (Nikoh *et al.*, 1994), although some authors have suggested that fungi are divergent from both animals and plants (Veuthey & Bittar, 1998). The largest subdivision within the fungal kingdom is the subkingdom Dikarya which contains $\sim 98\%$ of all described species and is further divided into the phyla Ascomycota and Basidiomycota (Hibbett *et al.*, 2007; Stajich *et al.*, 2009).

Phylum Ascomycota includes yeasts, filamentous fungi and some macrofungi. Ascomycetes are primarily haploid but during sexual reproduction form diploid offspring within an ascus which generally rapidly return to the haploid form. Asexual reproduction in the phylum is achieved through the production of conidia, which are thought to be the sole method of reproduction of those species with no known sexual stage. The majority of fungi known to cause disease in plants, animals and other fungi are members of phylum Ascomycota but others are known for their beneficial applications in areas such as brewing, biotechnology and biocontrol (Stajich *et al.*, 2009).

Phylum Basidiomycota includes rusts, smuts and mushrooms in their own subphyla (Pucciniomycotina, Ustilagomycotina and Agaricomycotina, respectively) and accounts for most macro-fungi, other than Morels. Members of the phylum include plant pathogens, insect pathogens, mycorrhizal fungi, wood degrading fungi, the human pathogen *Cryptococcus* (Nguyen *et al.*, 2010) and edible mushrooms, the most important in relation to this work being *Agaricus bisporus* (Hibbett *et al.*, 2007).

1.2 Genus: *Trichoderma*

Ascomycete fungi of the genus *Trichoderma* are ubiquitously distributed in nature and commonly account for the majority of fungi cultured from soil samples from a variety of habitats (Harman *et al.*, 2004) including arid near-desert, subtropical, tropical, temperate, sub-arctic and urban environments (Johnson *et al.*, 1987; Druzhinina *et al.*, 2005; Idress *et al.*, 2012). However, the diversity of *Trichoderma* species observed in soil is poor (Hagn *et al.*, 2007) and it has been suggested that these fungi adapted to the soil environment relatively late in their evolutionary history (Friedl & Druzhinina, 2012). Morphological characteristics common to most *Trichoderma* species include rapid growth and the production of abundant conidia (often green in colour) *in vitro*. Conidia are most commonly dry, small (<5 µm) and round or oval but are sometimes surrounded by a liquid droplet (*Gliocladium* like conidia) and may be smooth or rough. Chlamydospores are larger than conidia and are formed within the hyphae, or terminally, or not at all (Samuels, 1996).

Morphological methods for distinguishing *Trichoderma* are of limited usefulness as there is a high degree of similarity between species. Morphology may also vary within a population of a given species and with environmental factors. The lack of a sexual stage further complicates matters, as mating type identification is not possible for all species. These factors often lead to morphological taxonomy of *Trichoderma* species being limited to the identification of 'species-aggregates' which may contain a number of distinct species sharing common morphological characteristics (Samuels, 1996).

Molecular analysis of *Trichoderma* species can differentiate between species at a higher level of resolution than morphological methods because molecular characteristics vary more readily in *Trichoderma* than morphological ones (Taylor *et al.*, 2006). Molecular methods for distinguishing *Trichoderma* species include RAPD, selective PCR, DNA hybridisation, RFLP and comparative sequence analysis (Ospina-Giraldo *et al.*, 1998; Chen *et al.*, 1999a; Lu *et al.*, 2000; Staniaszek *et al.*, 2010). All of these methods can distinguish between morphologically identical *Trichoderma* species because divergent fungal populations can develop significant differences on a genetic level before any observable phenotypic

changes occur (Taylor *et al.*, 2006; Meincke *et al.*, 2010).

Non-DNA based molecular methods for species differentiation have also been applied to *Trichoderma* taxonomy. These methods rely on chemical analyses to describe phenotypes of *Trichoderma* species and classify them accordingly. This method of classification is described as chemotaxonomy and involves techniques such as HPLC (Thrane *et al.*, 2001) and LC/MS (Kang *et al.*, 2011) analysis of secondary metabolites, and the characterisation of specific enzymes and gene products which vary between species (Schickler *et al.*, 1998).

Species assignment based on a single product of metabolism can be subjective and careful attention must be given to assess the distribution of the compound in nature, but it is useful for analytical purposes when the production of the compound is the most relevant phenotypic characteristic exhibited by the fungus, as is the cases with compounds such as mycotoxins (Keller *et al.*, 2005). Chemotaxonomy based on a range of metabolites is more reliable and is referred to as metabolite profiling. Reference profiles can be generated from known species and directly compared to unknown isolates (Thrane *et al.*, 2001). This can allow species assignment as well as construction of phylogenetic trees based on profile similarity (Kang *et al.*, 2011). The presence and relative abundance of certain metabolites can be affected by culture conditions and age so standardisation is of utmost importance (Smedsgaard, 1997; Nielsen & Smedsgaard, 2003; Polizzi *et al.*, 2011). A chemical approach to taxonomy is an attractive compromise between morphological and molecular methods because it combines the advantage of grouping fungi displaying similar phenotypic characteristics and the ability to differentiate between similar species at a high level of resolution (Kang *et al.*, 2011). However chemotaxonomy is a relatively unexplored area of fungal taxonomy, with the overwhelming amount of research focusing on comparative sequence analysis (Mukherjee *et al.*, 2012).

Comparative sequence analysis is an expensive and time consuming method for species identification but from a taxonomic perspective it is the most useful because it allows direct comparison of data published by different authors. This means that classifications can be reviewed more easily in the light of new information. The principle of comparative sequence analysis is that genes common to related species differ somewhat in sequence due to mutations accumulated over

time. The degree of sequence divergence gives an indication of the evolutionary relatedness of the species. The most common application of comparative sequence analysis in *Trichoderma* taxonomy is ribotyping, in which conserved genes from the rDNA region of the genome are amplified by PCR and then sequenced (Dodd *et al.*, 2000). Conserved genes are desirable for this type of analysis because they are certain to be present in all specimens studied, however, a high degree of conservation limits the level of species resolution based on these genes (Druzhinina & Kubicek, 2005). The internally transcribed spacer regions (ITS 1 and ITS 2) are particularly popular targets for this type of analysis, but the validity of these genes as a criterion for species differentiation has been called into question based on the high degree of sequence similarity between closely related species and observation of paralogous copies of the genes in the same organism (Dodd *et al.*, 2000).

An inherent problem with comparative sequence analysis is that different genes evolve at different rates, either randomly, or due to selective pressure. So, it is possible for two species to be quite far removed in evolutionary terms, but to still share genes with identical sequences. Increasingly, molecular characterisations of microbes employ a multi-gene approach (Kullnig-Gradinger *et al.*, 2002; Chaverri *et al.*, 2003; Błaszczuk *et al.*, 2011). Each gene, when analysed separately, may produce a different clustering pattern for closely related species, by combining multiple genes a better overall picture is obtained, with species segregation being improved the more genes are analysed (Druzhinina & Kubicek, 2005).

The most powerful tool for the study of fungi on a molecular level is genomics. To date, full genome sequences have been produced for three *Trichoderma* (Figure 1.1); *Trichoderma reesei*, *Trichoderma atroviride* and *Trichoderma viride* (Martinez *et al.*, 2008; Kubicek *et al.*, 2011). Based on comparison of these genomes Kubicek *et al.* (2011) proposed mycoparasitism as the ancestral life-style of all *Trichoderma*. They found that *T. viride* and *T. reesei* are derived relative to *T. atroviride* but that *T. atroviride* and *T. viride* both shared a significant portion of mycoparasitism related genes. Kubicek *et al.* (2011) proposed that the most recent ancestor of the three species was a mycoparasite, but *T. reesei* (a plant necrotroph) subsequently lost many of the genes associated with this niche.

Martinez *et al.* (2008) found that while *T. reesei* has a considerably reduced mycoparasitic repertoire, it still maintains a significantly higher number of fungal cell wall degrading enzymes and non-ribosomal peptide synthetases than might be expected for a fungus which lives off decaying plant matter. *T. reesei* also possesses a surprisingly poor number of genes coding for plant cell wall degrading enzymes, to the point that it is incapable of fully degrading woody plant tissues.

Authors have proposed that many *Trichoderma* species are mycoparasite derived opportunists which are adapted to a wider range of ecological niches primarily due to their ability to suppress and antagonise other microbes which would otherwise out-compete them (Harman *et al.*, 2004; Druzhinina *et al.*, 2011). The presence of prey fungi in association with plant material and in the soil may have enticed ancestral *Trichoderma* species into new environments in which they gained a competitive edge by antagonising their competitors using the same mechanisms previously employed to parasitise host fungi. Kubicek *et al.* (2011) suggested that *T. reesei* is more suited to growth in wood that has been partially degraded by other microbes and that the nitrate reductase gene that is one of its adaptations to this niche (and which was obtained by horizontal gene transfer (Slot & Hibbett, 2007)) may even have even been co-opted from its ancestral Basidiomycete prey.

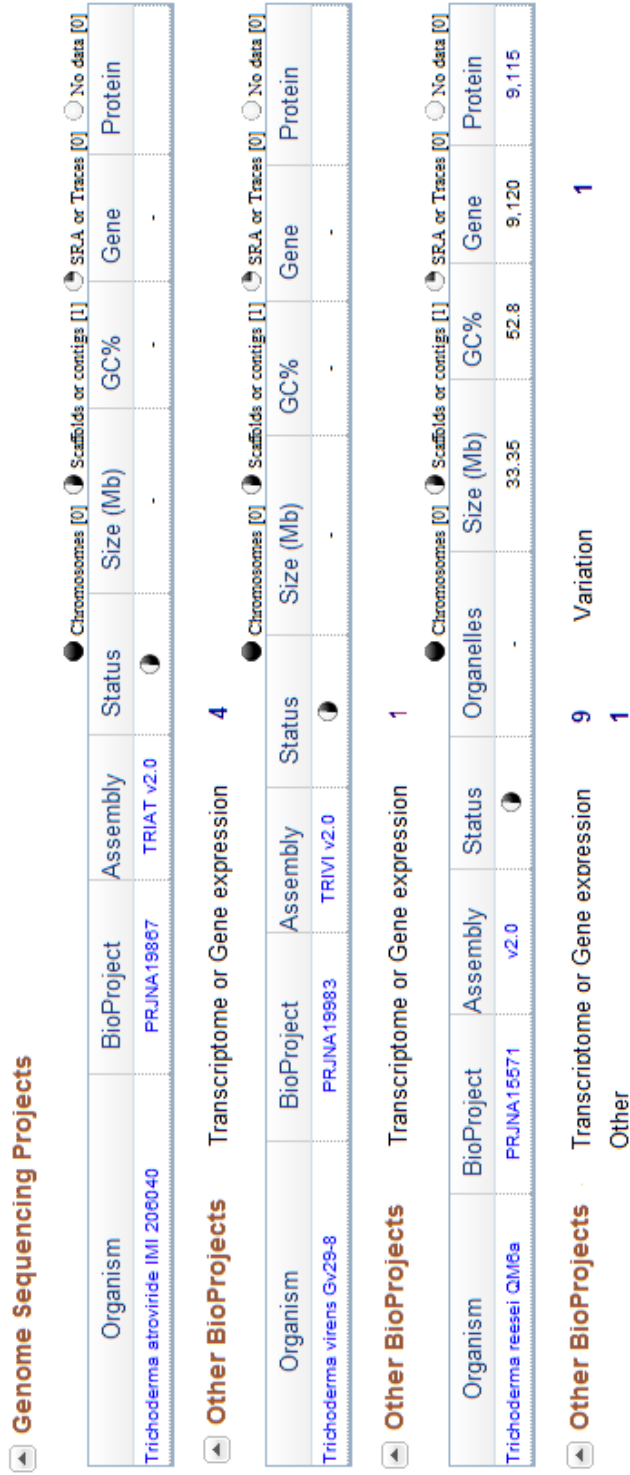

Fig. 1.1: Genome sequencing projects for *Trichoderma* species. Accessed from GenBank September 2012.

1.2.1 Anamorphs and Teleomorphs

Fungi from the genus *Trichoderma* are pleiomorphic, the asexual (anamorphic) and sexual (teleomorphic) life-cycle stages display distinct morphologies and ecologies. Teleomorphs of *Trichoderma* are found in the genus *Hypocrea*, a group of fungi first described in 1825 (Fries, 1825). Morphologically identical *Trichoderma* species may be distinguishable based on the morphology of their *Hypocrea* teleomorphs, however, some morphologically identical *Hypocrea* may have anamorphs classified as distinct *Trichoderma* species and *vice versa* (Dodd *et al.*, 2003). Not all *Trichoderma* have a teleomorph, some (like *Trichoderma aggressivum*) have only been described in the asexual state (Chaverri & Samuels, 2003). Classification of *Trichoderma* with no known teleomorphs is complicated by the reduced variety of morphological features and because the production of viable offspring through sexual reproduction is at the core of the biological concept of species.

At the time of writing the standard for naming of *Trichoderma/Hypocrea* species for which the entire lifecycle has been described is to assign the *Hypocrea* name to the species. Due to the genetic identity of anamorph and teleomorph there is an increase in the use of *Trichoderma* as the species name for *Hypocrea* with *Trichoderma* anamorphs. This will be the standard convention as of January 2013 (Druzhinina *et al.*, 2011).

1.2.2 Taxonomy of the *Trichoderma harzianum* group

Trichoderma harzianum as described by Rifai (1969) is one of the largest subgroups of *Trichoderma*. It can be divided into *T. harzianum sensu stricto*, the species *T. harzianum*, and *T. harzianum sensu lato*, a range of morphologically similar and related species (Druzhinina & Kubicek, 2005).

Gams & Meyer (1998) described the type specimen of *T. harzianum sensu stricto* (CBS 226.95) by analysis of rDNA sequence and RFLP. The species clusters with other *T. harzianum* and *Trichoderma inhamatum* strains and is more closely related to specimens which went on to be renamed *Trichoderma aggressivum* than to *Trichoderma atroviride* or *Trichoderma viride* (Figure 1.2). Further work by Dodd *et al.* (2000), Samuels *et al.* (2002), Kullnig-Gradinger *et al.*

(2002) and Chaverri *et al.* (2003) showed similar findings, and went some way to describing the diversity of species within the *T. harzianum* cluster as well as showing *T. harzianum sensu stricto* to be the asexual stage of *Hypocrea lixii*.

Reliable species assignment within the *T. harzianum* group has been an important topic of research because they are used in industry for the production of enzymes and as biological control agents for plant pathogenic fungi. At the same time related species are the cause of major economic losses within the mushroom industry (Ospina-Giraldo *et al.*, 1999). In order for safe application in the areas of biotechnology and biocontrol strict species identifications are absolutely necessary for safety evaluation. Patenting of products containing, or produced from *T. harzianum* also calls for accurate species description. In spite of this, phylogeny within the *T. harzianum* cluster is still poorly described and there are strains described as *T. harzianum* which may be distinct species or subspecies (Druzhinina & Kubicek, 2005). Some of the strains used in industry are described as *T. harzianum*, in spite of them differing significantly from *T. harzianum sensu stricto* (Mach *et al.*, 1999). Since the degree of genetic and phenotypic difference required to define new subspecies is poorly defined this is likely to remain the case for some time.

1.3 *Trichoderma aggressivum*

Trichoderma aggressivum is a *Trichoderma harzianum*-like species found exclusively in association with the cultivation of the edible mushroom *Agaricus bisporus*. It is the most significant causative agent of green mould disease in *A. bisporus* cultivation. Green mould disease describes the growth of *Trichoderma* species in the substrate and casing used for mushroom production. This causes reduced mushroom formation and damage to *A. bisporus* fruiting bodies, resulting in economic losses in the mushroom industry. The condition can be caused by many *Trichoderma* species but in the cultivation of *A. bisporus*, *T. aggressivum* is the only species known to cause total crop failure.

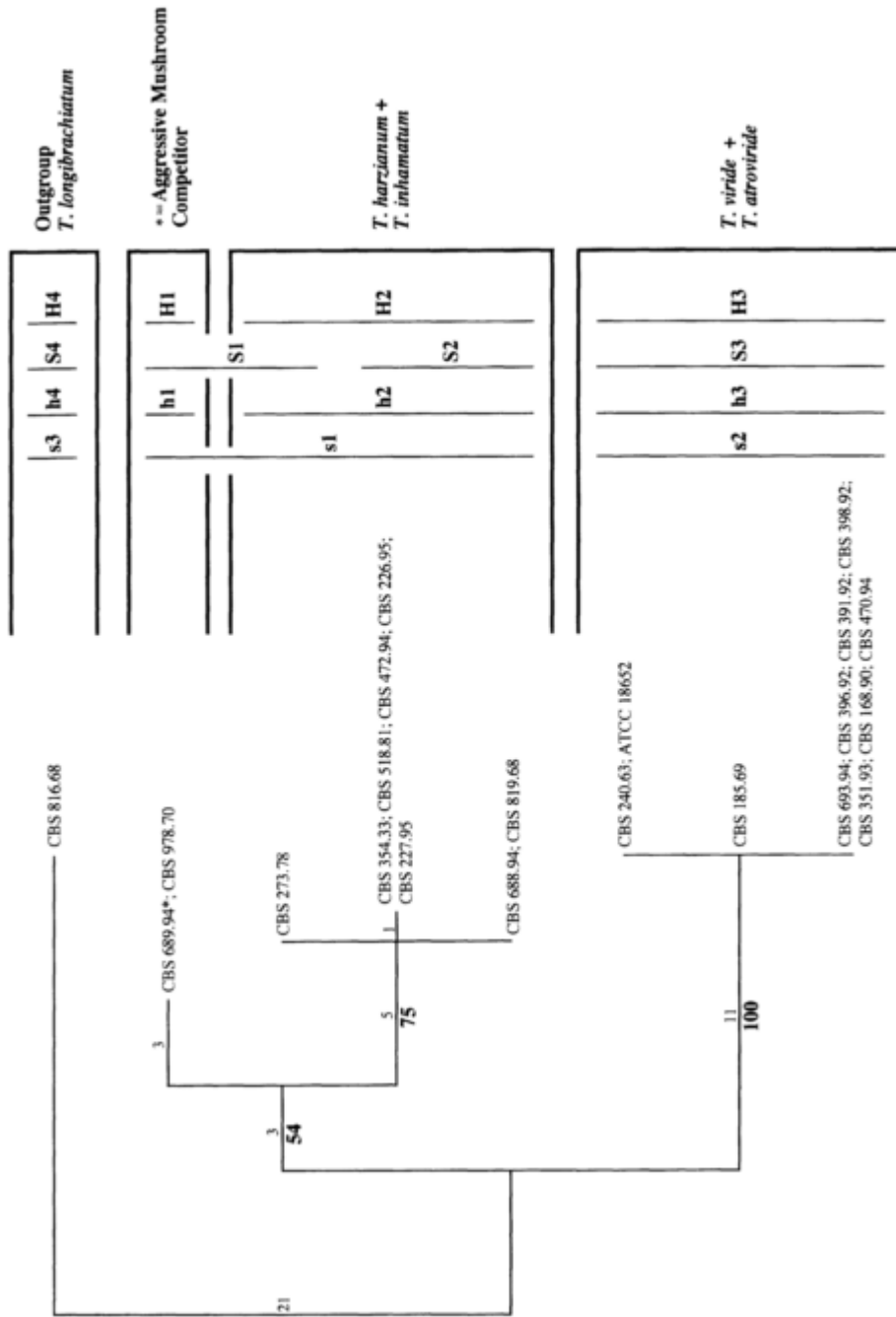

Fig. 1.2: Phylogenetic tree of *Trichoderma harzianum sensu lato* based on rDNA sequencing and RFLP analysis.

Reproduced from Gams & Meyer (1998).

1.3.1 Early identification

Trichoderma aggressivum was originally identified in Ireland during an outbreak of severe green mould disease in the late 1980s (Seaby, 1987; Staunton, 1987; Seaby, 1989). Seaby (1987) identified three subgroups of *Trichoderma harzianum* involved in the outbreak which were distinct from each other but all exhibited morphology typical of *T. harzianum* (Rifai). These subgroups were assigned the names Th1, Th2 and Th3. The Th2 subgroup was found to be the most significant group involved in the outbreak and the one causing the most severe damage to mushroom crops.

Subsequent outbreaks of severe green mould disease were reported in Britain (Muthumeenakshi *et al.*, 1994), the US (de la Fuente *et al.*, 1998), Canada (Royse *et al.*, 1999), Spain (Hermosa *et al.*, 1999), France (Largeteau *et al.*, 2000a) and across Northern Europe (Kredics *et al.*, 2010; Sobieralski *et al.*, 2010). The Th2 group was found to be the cause of the outbreaks in *A. bisporus* crops in Europe, while phylogenetically distinct but related species are responsible for severe green mould disease of *A. bisporus* in North America (Th4) and in the production of other edible mushrooms worldwide (*Trichoderma pleurotum*, *Trichoderma pleuroticola* and others) (Muthumeenakshi *et al.*, 1998; Hatvani *et al.*, 2007; Komon-Zelazowska *et al.*, 2007; Kredics *et al.*, 2009).

1.3.2 Species assignment

Most of the literature published regarding *Trichoderma* in mushroom production during the 1990s uses the biotype nomenclature, classifying the most relevant *Trichoderma* strains as *Trichoderma harzianum* biotypes Th1, Th2, Th3 and Th4. These biotypes were distinguishable based on morphology and growth rates, but due to the continuum of morphologies and growth types observed within *T. harzianum sensu lato* identification and comparison based on these traits is problematic. During the fifteen years following the first description of the biotypes there was an increasing amount of molecular data pointing towards evolutionary divisions between the biotypes.

Muthumeenakshi *et al.* (1994) described intraspecific polymorphisms between 81 *Trichoderma* isolates using RFLP of the mitochondrial DNA and PCR am-

plified rDNA as well as ITS 1 sequence and RAPD. Their results distinguished aggressive Th2 strains from the non-aggressive Th1 and Th3 biotypes as well as showing that strains exhibiting the aggressive phenotype which had been previously classified as Th1 or Th3 based on morphology clustered better with the Th2 strains based on molecular similarities.

Seaby (1996a) differentiated the biotypes based on extensive microbiological methods. The growth characteristics of each biotype and several other *Trichoderma* species were assessed at a range of temperatures and they were examined microscopically on different growth media. Using different growth conditions a wider range of morphologies was observed which can allow better differentiation of species which exhibit very similar morphologies and growth rates under the same culture conditions.

Muthumeenakshi *et al.* (1998) compared Th2 strains and aggressive strains isolated from mushroom farms in North America to assess whether they were the same biotype, which might indicate that they had spread to North America from Europe. Their findings reinforced the genetic segregation of the Th1, Th2 and Th3 biotypes and showed that aggressive North America isolates were genetically distinct from Th2. They proposed that the North American mushroom competitors was not imported from Europe, but was a closely related indigenous strain exploiting the same niche as Th2. They continued the use of the term Th4 to describe this North American biotype, as had already been done by Seaby (1996a).

Castle *et al.* (1998) used a similar approach to Muthumeenakshi *et al.* (1994) to study *Trichoderma* strains isolated from mushroom farms across North America. In this study a subgroup of 40 % of isolates which exhibited the same RAPD character were identified as being those most commonly associated with severe green mould disease. This study also confirmed that these Th4 isolates were similar to Th2 isolates from Europe but that the two were genetically distinct.

Ospina-Giraldo *et al.* (1998) used sequence analysis of the ITS-1, ITS-2 and 5.8S rDNA genes to delineate the biotypes Th1, Th2 and Th4 from Th3, which was shown to display more genetic identity with *Trichoderma atroviride*. Their analysis showed that the biotypes Th1, Th2 and Th4 showed a small number of nucleotide differences in the sequenced regions relative to one and other and that

they grouped together, with Th2 and Th4 being more similar to each other than to Th1. Th3 by contrast was highly divergent and did not group with any of the other *T. harzianum* biotypes (Figure 1.3). The term *T. harzianum* Th3 was subsequently abandoned, in favour of *T. atroviride* to describe these strains.

Several papers published in 1999 showed that the Th2 and Th4 biotypes were divergent from other *Trichoderma* strains that are used in biocontrol (Ospina-Giraldo *et al.*, 1999), and that the Th4 biotype was not the primary variety associated with green mould disease in the United States prior to the epidemic of the early 1990s (Chen *et al.*, 1999b). A PCR based test which could distinguish the Th2 and Th4 biotypes from non-aggressive strains was developed based on a RAPD fragment unique to those biotypes (Chen *et al.*, 1999a). These results again emphasised that there is more genetic similarity between the Th2 and Th4 biotypes than there is between those biotypes and other *Trichoderma* varieties.

Dodd *et al.* (2000) used multiple gene sequences from the rDNA region to describe the relationship between *Trichoderma* strains. This data supports that of Ospina-Giraldo *et al.* (1998) in classifying biotype Th3 as *T. atroviride* and grouping the other biotypes together but, depending on which gene was used for tree construction four different evolutionary relationships between biotypes Th1, Th2 and Th4 were supported with no consensus tree and low bootstrap values in all cases. This is likely as a result of the low-level of rDNA polymorphism between these biotypes observed by Ospina-Giraldo *et al.* (1998).

In 2002 the three remaining mushroom associated *Trichoderma* biotypes were reclassified. Based on available sequence data as well as novel sequences for the *tef-1* gene Samuels *et al.* (2002) reclassified Th1 isolates as *T. harzianum sensu stricto* while the European and North American mushroom competitors Th2 and Th4 were reclassified as *Trichoderma aggressivum* f. *europaeum* and *Trichoderma aggressivum* f. *aggressivum*, respectively. Further multi-gene sequencing analyses supported this assessment, with both *T. aggressivum* subspecies being closely related but distinctly divergent from *T. harzianum sensu stricto* (Kullnig-Gradinger *et al.*, 2002; Chaverri *et al.*, 2003).

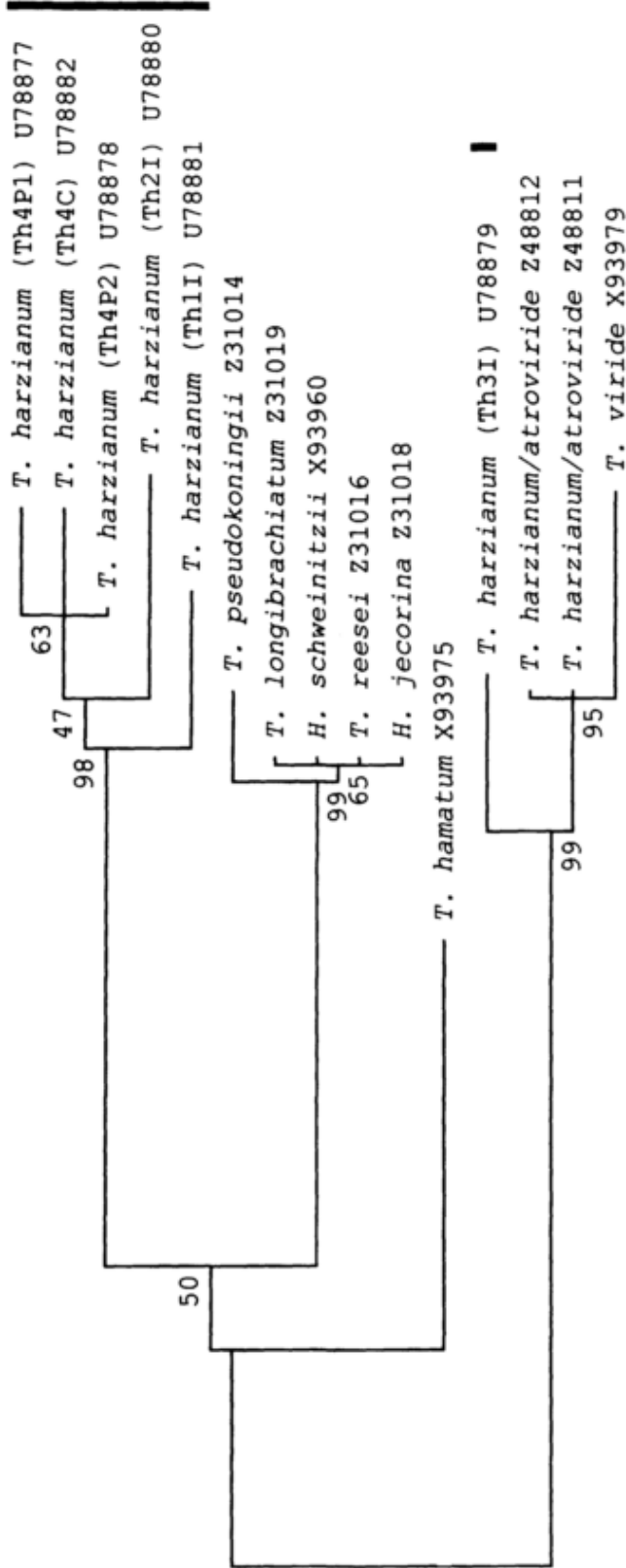

Fig. 1.3: Phylogenetic relationship of mushroom associated *Trichoderma harzianum* biotypes. Reproduced from Ospina-Giraldo *et al.* (1998). Tree obtained from comparative sequence analysis of rDNA region. Mushroom associated specimens indicated with sidebars.

1.3.3 Cultural and morphological characteristics

Trichoderma aggressivum is fast growing, MEA cultures typically grow $\sim 1\text{mm/hr}$ at $27\text{ }^\circ\text{C}$ and half that rate at $17\text{ }^\circ\text{C}$ (Seaby, 1996a). Optimum growth temperature is in the $25\text{-}30\text{ }^\circ\text{C}$ range on PDA, growth is significantly reduced at $35\text{ }^\circ\text{C}$ (Samuels *et al.*, 2012). Conidia are smooth, green, obovoid and $\sim 3.4\text{ }\mu\text{m}$ in diameter. Conidiation is typically observed at the colony edge and in central pustules within ~ 96 hours in the dark (Seaby, 1996a). Early conidiation is enhanced by growth under a light source but formation of conidia is not light dependent (O' Brien, unpublished data).

Phialides are flask shaped and held in branched conidiophores. Conidiophore branching may be paired or unpaired. Long 'internode' regions are frequently observed between clusters of conidiophores. Chlamydospores are formed rarely or not at all. The European and North American subspecies are not distinguishable at a microscopic level (Samuels *et al.*, 2012).

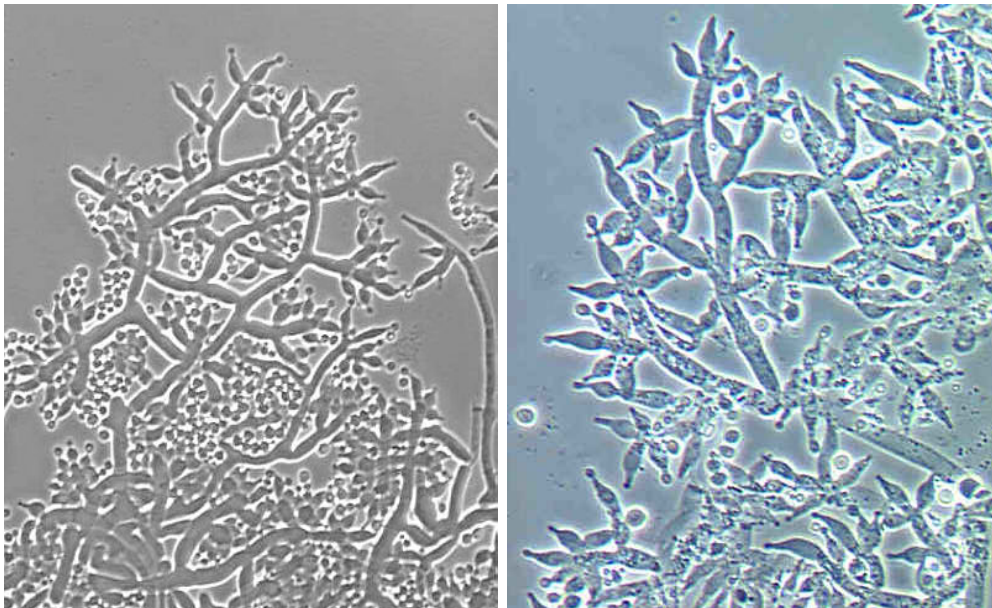

Fig. 1.4: Conidiophores of *Trichoderma aggressivum* f. *europaeum* (Left) and *Trichoderma aggressivum* f. *aggressivum* (Right).

Images reproduced from Samuels *et al.* (2012)

1.4 Cultivation of *Agaricus bisporus*

Mushrooms of the genus *Agaricus* have been cultivated for consumption since the 18th century (Abercrombie, 1779). Today *Agaricus bisporus*, the white button mushroom is the most commonly cultivated mushroom in Europe and North America. Other *Agaricus* varieties such as *Agaricus subrufescens* and *Agaricus bitorquis* are popular in warm climates such as Brazil due to their ability to produce fruiting bodies at higher ambient temperatures (Hernández *et al.*, 2011). Most *A. bisporus* strains cultivated worldwide are hybrids, valued for their smooth, white sporophores and high yields of good quality mushrooms (Diamantopoulou & Philippoussis, 2001).

Worldwide production of mushroom is in the order of tens of millions of metric tonnes. Figure 1.5 shows the production of mushrooms by the top nine mushroom producing nations since 1990. The most significant trend is the increase in production in China, which is by far the largest producer of mushrooms globally, but of this *A. bisporus* only accounts for only a fraction (Chen *et al.*, 2008). Most nations show a gradual increase in production over the 20 years apart from the UK and France, in which production declined (France was one of the top producers until 2008); the USA, which remained mostly constant; and Italy, in which production increased considerably between 2006 and 2010.

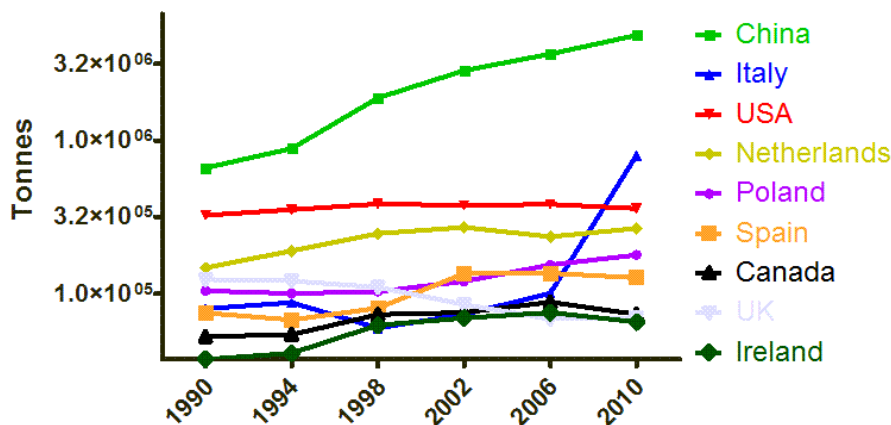

Fig. 1.5: Annual output of top 10 mushroom producing nations from 1990-2010

Figures from faostatistics.

1.4.1 Mushroom cultivation systems

Mushroom production is a multi-step process (Figure 1.6). The first 2 phases involve the production of mushroom substrate from raw materials by biological composting processes. The substrate and casing is colonised by *Agaricus bisporus* mycelium in subsequent phases, then fruiting body formation is induced and mushrooms are harvested. Each of these steps is carefully controlled to maximise mushroom yield and quality and to minimise the opportunity for contamination with unwanted micro-organisms. Each phase is described in detail below.

Phase I

Phase I is the first stage of mushroom substrate production. The raw materials for this phase are straw (preferably wheat straw), manure (poultry, horse, or other, depending on local availability) and gypsum (Pecchia *et al.*, 2002). Raw materials are mixed and wetted in piles; this process may take place in an open air yard or covered bunkers may be used (Sharma *et al.*, 2000). Piles are turned and wetted repeatedly to ensure the components are thoroughly mixed and to prevent the production of excessive heat or anaerobic conditions within the compost (Royse & Chalupa, 2009).

There is no requirement for the addition of heat during Phase I; the breakdown of the nutrient rich straw and manure by naturally occurring micro-organisms produces significant amounts of heat (Anastasi *et al.*, 2005). Temperatures can reach up to 80 °C in the centre of compost piles (Van Griensven & Vogels, 1990) with thermophilic microbes proliferating as temperatures rise. Thermophilic bacteria and fungi are important to the Phase I process (Fordyce, 1970; Straatsma *et al.*, 1991; Maheshwari *et al.*, 2000; Singh *et al.*, 2005; Sanchez *et al.*, 2008). These organisms partially breakdown the raw materials and sequester inorganic nitrogen and carbon, making the substrate more amenable to the growth of *Agaricus bisporus* and less accessible to competitors. The dynamic microbial population during Phase I a key part of the production of high yielding mushroom substrate and inoculation of the compost with cultures of beneficial microbes has been studied as a means of improving substrate quality (Straatsma *et al.*, 1991; Singh *et al.*, 2005; Adams & Frostick, 2008).

There is increasing interest in the use of by-products from food, agriculture and other industries in the production of mushroom substrate (Kurbanoglu *et al.*, 2004; Stoknes *et al.*, 2008; Parati *et al.*, 2011; Philippoussis & Diamantopoulou, 2011; Savoie *et al.*, 2011). The primary materials used in the production of substrates for the cultivation of *A. bisporus* and other mushrooms are by-products of the production of cereals and livestock. Bioconversion of agricultural and other waste products into edible mushrooms improves food production efficiency and promotes sustainability (Savoie *et al.*, 2011). In addition, as both wheat straw and chicken manure are in demand for other uses and contribute significantly to the cost of producing mushroom substrate, so the utilisation of other raw materials can reduce the cost of mushroom production (Martin, 2008).

Phase II

The next stage of composting takes place in aerated bunkers. Compost temperature is raised to 60 °C for 8 hr to pasteurise the compost with the intention of killing any unwanted microbes which may be present in the raw materials of Phase I. Modern composting facilities typically make use of forced aeration through channels in the bunker floor to ensure that the process is fully aerobic as well as for temperature control (Noble & Gaze, 1994). After pasteurisation the temperature is reduced to 45 °C and composting proceeds until all ammonia and other readily available nitrogen sources in the compost have been re-assimilated by compost micro-flora (Noble & Gaze, 1996).

Inefficient aeration and temperature control during Phase II can lead to the production of unwanted gases such as H₂S and ammonia vapour and can result in the production of substrate which produces low yields of mushrooms and is susceptible to infection with other micro-organisms (Noble & Gaze, 1996). After Phase II the compost is a uniform brown colour with softened straws of short length and no odour. At this point the substrate is ready for inoculation with *Agaricus bisporus*.

The objective of Phase II is to produce a substrate which is free from microbes which are pathogens or competitors of *A. bisporus* and which has a low concentration of readily available nitrogen and carbohydrate. Low abundance of easily acquired nutrition favours the growth of *A. bisporus* over undesired

organisms in the later stages of production. *A. bisporus* is a secondary decomposer of plant matter which is able to degrade difficult-to-digest components of plant cells such as lignin (Patyshakuliyeva & De Vries, 2011). The degradation of lignin in mushroom compost and also increases the availability cellulose and hemi-cellulose, which in turn can be broken down into high energy molecules such as glucose and 5-carbon sugars (ten Have *et al.*, 2003). Well prepared Phase II compost acts as a semi-selective medium for the growth of *A. bisporus* as it does not contain carbon or nitrogen sources which are readily available to organisms which do not have the enzyme complement necessary to break down this complex substrate (Durrant *et al.*, 1990).

Phase III

Phase III is the first stage in the growth of *Agaricus bisporus* but is also described as one of the stages of compost production. Mushroom spawn is added to the Phase II compost, ambient temperature is adjusted to 25 °C and air humidity is raised to 90 %, this process is commonly referred to as spawn-run. After Phase III the substrate is fully colonised with *A. bisporus* mycelium and mottled white in appearance.

Mushroom spawn is a pure culture of *A. bisporus* mycelium grown on grains such as barley or rye which is used to inoculate the Phase II compost (Sánchez, 2004). *A. bisporus* strains are produced through selective breeding (Sonnenberg *et al.*, 2011), mycelium is used as inoculum instead of spores to prevent sexual recombination which might alter the properties of the strain and because spores have a low germination rate and may transfer viral diseases. Measures are usually taken by the producer to prevent the exposure of substrate or casing material to spores from mature mushrooms on-site to prevent the transmission of viral diseases and crossing between spores and mycelium (Callac *et al.*, 2006).

The most important microbe during Phase III is *A. bisporus*. Pains are taken to exclude any other organisms from the substrate at this point and the mushroom spawn is produced under high levels of sanitation to produce culturally and genetically pure spawn (Scrase, 1995; Sharma *et al.*, 2008).

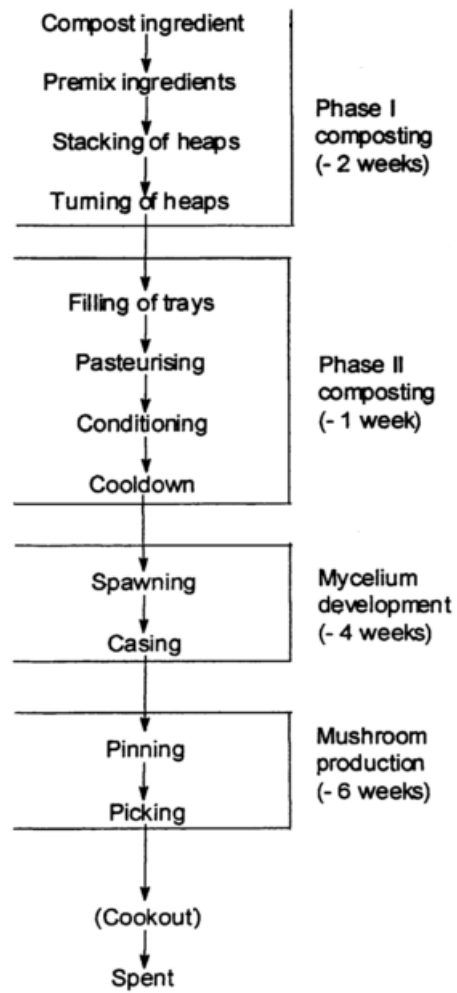

Fig. 1.6: Outline of mushroom production process.

Modified from (Iiyama *et al.*, 1994).

Phase IV

Phase IV of mushroom production begins with the addition of a layer of casing soil to the top of the *Agaricus bisporus* colonised substrate. The casing layer is typically made up of a blend of peat, sphagnum moss and lime (Barry *et al.*, 2008). Mushroom compost may be commercially available as Phase IV, pre-cased substrate but it is more common for the casing to be added by the grower in-house.

After the addition of casing a period of time is assigned to allow the *A. bisporus* to fully colonise the casing layer, casing inoculum matching the strain used in Phase III may be added to speed the colonisation process. Substrate temperature is reduced to ~ 20 °C, humidity is maintained at 95-100 % and the crop is watered on a regular basis until the formation of fruiting body primordia (pins) becomes visible on the casing surface (Royse & Chalupa, 2009). Water is essential to the formation of fruiting bodies as fruiting body tissue has a high water content, however application of water directly on fruiting bodies impedes their growth (Noble & Spurdens, 2000) and may cause damage or discolouration, so water is typically withheld from the onset of pinning till the end of each flush of cropping.

After mushrooms have been harvested from the substrate undersized pins and residual fruiting body tissue are removed and watering begins again. In this way a new flush of mushrooms is induced to form. Five or more flushes of mushrooms may be obtained from a single batch of substrate but with each successive flush the yield per unit area is reduced and the likelihood of pests and diseases occurring increases (Staunton & Dunne, 1997). For this reason most commercial mushroom producers harvest mushrooms in 3 flushes or less (Van Griensven & Van Roestel, 2004).

Casing soil is a vital component of the mushroom production system, fruiting bodies cannot be induced to form without the addition of casing (Noble *et al.*, 2003). The role of the casing layer is three-fold, it must: absorb and hold moisture, increasing the level of water available for the formation of fruiting bodies and preventing damage cause by drying out of the substrate; have a consistency which facilitates penetration of mycelial strands which supply nutrients and water

to fruiting bodies from the substrate; and contain the microbial content necessary to induce the formation of fruiting bodies (Vernooij, 2008).

The exact mechanism by which casing induces fruiting body formation is unknown. The activities of *Pseudomonas putida* is known to stimulate fruiting body formation, but whether the stimulation is caused by secreted factor from the bacterium or an indirect result of the growth of *P. putida* is not clear (Zarenejad *et al.*, 2012). Fruiting body formation has been observed in casing substitutes devoid of *P. putida*, so it has been suggested that the interaction may involve the removal of an endogenous suppressor of fruiting body formation produced by *A. bisporus* (Noble *et al.*, 2003).

Post harvest and spent mushroom substrate

After the cropping cycle mushroom substrate, casing and facilities are treated with high temperature steam. This process kills pests which may have been present in the crop, prevents cross contamination between crops and cleans the facilities for the next batch of substrate. The spent mushroom substrate (SMS) is then disposed of.

After the growth of *A. bisporus* SMS still contains a significant organic matter content as well as essential nutrients (Jordan *et al.*, 2008). SMS has been used for a long time as a soil supplement. It increases the porosity of heavy clay soils and the water holding capacity of light sandy soils as well as adding nitrogen and phosphorus which are available for uptake by plants; however, it often has a high electrolyte content as well as a heterogenous composition which must be assessed for effective use as a fertiliser (Rao *et al.*, 2007; Jordan *et al.*, 2008; Paredes & Medina, 2009; Danai *et al.*, 2011). SMS has a complex and variable microbial content, even after steam treatment, however the absence of potential human pathogens such as *Campylobacter* and *Salmonella* which are commonly associated with manure based soil amendments makes it more suitable for use on agricultural soils (Watabe *et al.*, 2004; Rao *et al.*, 2007).

Spent mushroom substrate is also biologically active and has been used in such applications as bioremediation of contaminated soils (Chiu *et al.*, 2009), detoxification of textile effluents (Ahlawat & Singh, 2009), as a source of raw enzymes (Singh *et al.*, 2003), a supplement for animal feed (Ayala *et al.*, 2011) and as a

replacement for casing soil in the production of further mushroom crops (Barry *et al.*, 2008). These add to the potential of mushroom cultivation in promoting sustainable agriculture as it allows waste organic material from other industries to be transformed into a food-source, while the by-products of mushroom production themselves can be recycled into other useful materials.

1.4.2 The Bulk Phase III system

The Bulk Phase III mushroom system involves the production of mushroom substrate up until the end of spawn-run in large batches by the compost producer before it is transferred to the mushroom producer for Phase IV and the cropping cycle. This system is different to older *in situ* spawn-run systems where Phase III is carried out in-house by the mushroom grower.

Bulk Phase III production is advantageous to the grower because it allows for a faster cropping cycle and therefore more crops per year (Van Griensven & Van Roestel, 2004). The Phase III substrate is already colonised by *Agaricus bisporus* mycelium and the grower need only apply the casing layer and allow it to become colonised before the cropping cycle can begin. The faster turn-around of crops generally leads to a more productive mushroom farm which offsets the higher cost of Phase III substrate over Phase II substrate.

The production of Bulk Phase III substrate is more technologically advanced than older production systems. Facilities are purpose built with environmental control and sanitation in mind and there is a high level of automation. This means that Bulk Phase III substrate is usually more consistent, more productive and less susceptible to pests.

Bulk Phase III produced substrate is transported from the producer to the grower in large volumes. Unlike older production systems the substrate is not typically dispensed into bags during shipping and spawn run *in situ*. Instead it is emptied directly into trucks and transported to the grower where it is filled into trays or shelves and cased. This process is referred to as bulk handling.

While this system is less prone to contamination with unwanted micro-organisms the nature of bulk substrate production raises concern over the impact that contamination at such a facility could have. Many mushroom producers may source substrate from the same supplier so contamination of a single batch of Bulk Phase

III substrate could have more serious knock-on effects than the smaller volumes produced in Phase II systems. The division of substrate into bags in Phase II production systems may also present a barrier to the spread of infected material within a batch of substrate (Seaby, 1996b). Bulk handling at the end of Phase III can cause substrate from different parts of the Phase III tunnel to be mixed together, which may spread infection throughout the substrate if it escaped detection during the Phase III process.

The Bulk Phase III is becoming more common in Europe but there is still relatively little information on the transmission and propagation of various mushroom pests and diseases within the system. While outbreaks of *Trichoderma aggressivum* green mould disease are less common with the use of Bulk Phase III substrate they still occur (Lemmers, 2010).

1.5 *Trichoderma aggressivum* in the mushroom industry

1.5.1 Symptoms and identification

The point at which *Trichoderma* green mould infection is identified in a mushroom crop varies with the severity and stage of infection as well as the *Trichoderma* species responsible. *Trichoderma aggressivum* is the species most commonly found growing within the mushroom substrate (Largeteau *et al.*, 2000a), it may become evident to visual inspection after Phase III (Figure 1.7 A) but depending on the severity of infection the onset of symptoms may be delayed.

T. aggressivum infection is often identified during the cropping cycle when green-sporulating patches of mycelium become visible on the casing surface (Figure 1.7 B). Growers may be aware of a problem before the first appearance of spores due to a restricted pattern in pinning or colonisation of casing layer by *Agaricus bisporus* mycelium or by an inability to control compost temperature during room venting caused by increased biological activity in infected compost. At this stage the damage is already done to the crop as *T. aggressivum* colonises the mushroom substrate below the casing layer first and becomes highly antagonistic towards *A. bisporus* upon sporulation (Largeteau *et al.*, 2000b).

Other species of *Trichoderma* which occasionally grow on mushroom substrate or casing are difficult to distinguish from *T. aggressivum* visually (Seaby, 1996a).

A positive identification of species requires a PCR test, usually after culturing the fungus *in vitro* (Chen *et al.*, 1999a; Williams *et al.*, 2003b). If a *Trichoderma* species other than *T. aggressivum* is the cause of the green mould then the damage will likely be limited, but if *T. aggressivum* is present then there is a higher likelihood of widespread contamination; it may be advisable to terminate the crop early and proceed immediately to steam cook-out (Staunton & Dunne, 1997).

Early detection of infection is crucial when *T. aggressivum* is involved. Culture based screening of compost and raw materials is a method for monitoring *Trichoderma* levels on a farm or composting facility, however species assignment in such cases is usually presumptive, so this method is most useful for producers who have experienced problems with *T. aggressivum* previously. A direct PCR method can be used to detect *T. aggressivum* from mushroom substrate, which may be useful for monitoring purposes (Grogan *et al.*, 2012), but this cannot be employed in stages of the cropping process from which personnel are excluded (i.e. bunker stages of Phases 2 and 3). Baars *et al.* (2011) developed a method for detecting specific volatiles emitted by *T. aggressivum* growing in mushroom substrate *in vitro* using GC/MS which is further developed in Baars *et al.* (2012). This presents an attractive potential method for the detection of *T. aggressivum* by sampling head-space gases from sealed tunnels, identifying *Trichoderma* infection on a species specific level while eliminating the requirement for access and sampling problems associated with other methods.

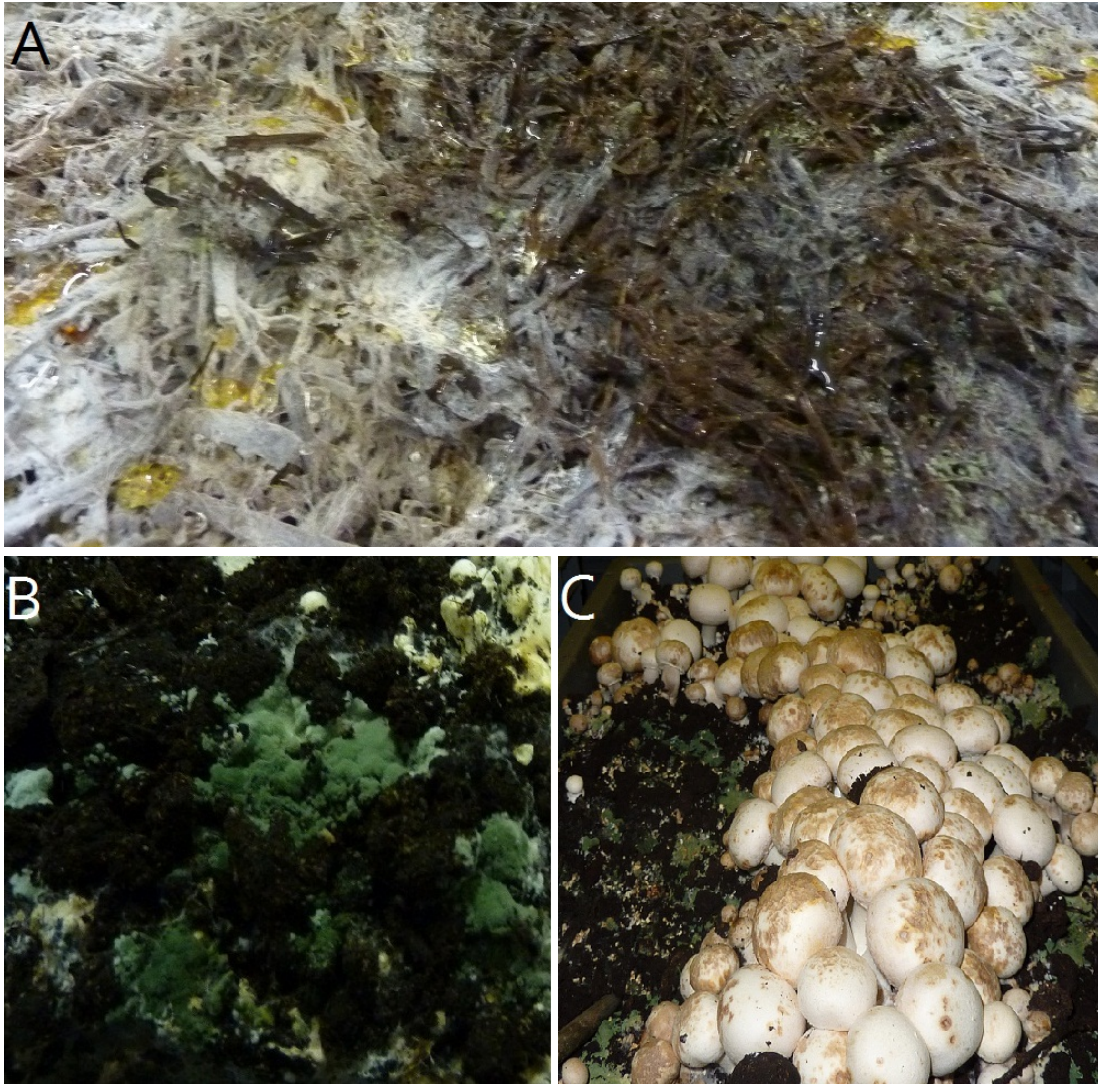

Fig. 1.7: Symptoms of *Trichoderma aggressivum* infection at different stages of the cropping cycle

A - *T. aggressivum* colonisation of Phase III compost visible as dark patch with low-levels of green-sporulation. B - Heavy sporulation of *T. aggressivum* on casing surface during cropping first flush. C - Discolouration of *Agaricus bisporus* sporocarps during second flush caused by contact with *T. aggressivum*.

1.5.2 Impact on crops

Trichoderma aggressivum grows in mushroom substrate below the casing layer, the same area occupied by the bulk of *Agaricus bisporus* mycelium and the primary source of nutrients for the formation of fruiting bodies. The general effect of *T. aggressivum* is observed as the presence of bare areas on the casing surface from which no mushrooms form, caused by the activities of *T. aggressivum* beneath the surface which may then grow through the casing layer producing visible green spoulation. The presence of *T. aggressivum* may also cause cap spotting (Figure 1.7 C) and deformation of fruiting bodies (Sharma *et al.*, 1999). This is a secondary effect of infection but also contributes to loss of saleable mushrooms.

Yield losses have been recorded in the region of 5-100 % (Sobieralski *et al.*, 2010; Rinker, 1997; Sharma *et al.*, 1999; Danesh *et al.*, 2000; Grogan *et al.*, 2012), considerably higher than with other species of *Trichoderma* (Sharma *et al.*, 1999; Grogan *et al.*, 2000). The economic impact of *T. aggressivum* on the mushroom industry has been estimated in the millions of euro (Seaby, 1996a; Kredics *et al.*, 2010).

Recovery of crops after the initial outbreak of green mould has been observed (Guthrie & Castle, 2006). Fruiting bodies may form in areas that were previously colonised by *T. aggressivum*, but due to the delay and reduction in yield this is usually not enough to allow for the grower to recover the costs of substrate, staff and power.

1.5.3 Mechanism of action

The exact mechanisms by which *Trichoderma aggressivum* interacts with *Agaricus bisporus* and impedes fruiting body formation are unknown. There are two main hypotheses, the first is that *T. aggressivum* exhibits a parasitic activity towards *A. bisporus*, the second is that competition for space and nutrients in the mushroom substrate is the primary cause of fruiting inhibition, there is evidence for both.

Parasitism of *A. bisporus* by *T. aggressivum* is plausible given the ecological niche occupied by many *Trichoderma* species. Most *Trichoderma* species are either mycoparasites (many of which primarily prey upon Basidiomycetes) or

are derived from species with this lifestyle (Kubicek *et al.*, 2011; Druzhinina *et al.*, 2011). The species most closely related to *T. aggressivum* is *Trichoderma harzianum*, which is a hyperparasite used in the biological control of several plant pathogenic fungi (Druzhinina & Kubicek, 2005; Thornton & Dewey, 1996).

Mycoparasitic *Trichoderma* species possess a variety of adaptations which allow them to feed directly on living fungal tissues. These adaptations include sensory faculties which allow the detection of other fungi (Inbar & Chet, 1995; Seidl *et al.*, 2009); a range of antifungal secreted metabolites which are induced in the presence of prey fungi (Rubio *et al.*, 2009; Montero-Barrientos *et al.*, 2011), including cell wall degrading enzymes (Carsolio *et al.*, 1999; Sanz *et al.*, 2005; da Silva Aires *et al.*, 2012); the ability to detoxify suppressive metabolites secreted by other fungi (Seidl *et al.*, 2009); and the formation of specialised hyphal structures which allow penetration of host hyphae and the direct absorption of nutrients from the intercellular space (Harman *et al.*, 2004). Several, but not all of these characteristics have been observed during interaction between *T. aggressivum* and *A. bisporus* (Williams *et al.*, 2003b).

T. aggressivum is described as the *Trichoderma* species most commonly found growing in areas of mushroom substrate colonised by *A. bisporus* (Seaby, 1996a) and while *T. aggressivum* is capable of growing in mushroom substrate in the absence of *A. bisporus* it does not sporulate as heavily in such a situation (Largeau *et al.*, 2000b). Other species of *Trichoderma* occurring in compost are more often found in areas devoid of *A. bisporus* with a clear divide between the areas occupied by the two fungi (Sharma *et al.*, 1999). Observed co-localisation *in vivo* as well as studies showing that the growth of *T. aggressivum* is promoted by metabolites produced by *A. bisporus in vitro*, while other *Trichoderma* species are impaired (Mumpuni *et al.*, 1998) support the hypothesis that *T. aggressivum* may grow toward *A. bisporus* in a directed fashion.

Several metabolites secreted by *T. aggressivum* have been shown to hamper the growth of *A. bisporus* (Mumpuni *et al.*, 1998; Krupke *et al.*, 2003). These include enzymes which degrade components of the fungal cell wall (Williams *et al.*, 2003a; Guthrie & Castle, 2006). However metabolites secreted by *T. harzianum* have a more severe impact on the growth of *A. bisporus in vitro* (Mumpuni *et al.*, 1998). *T. harzianum* is known for its highly antagonistic activity towards

a range of fungal species, it is used industrially for the production of chitinase (Nampoothiri *et al.*, 2004) as well as in the biological control of several fungal diseases of plants (Otieno *et al.*, 2003; Verma *et al.*, 2007; Montero-Barrientos *et al.*, 2011). While *T. harzianum* is a highly successful, opportunistic mycoparasite and often found on mushroom farms it is a relatively minor problem compared to *T. aggressivum*.

The ability of *T. aggressivum* to overcome inhibition by *A. bisporus* has been displayed *in vitro* by its ability to overgrow 'brown-rings' formed by the secretion of laccase and other enzymes which are part of the response of *A. bisporus* to the growth of competitors (Savoie *et al.*, 2001b; Savoie & Mata, 2003). The ability to overcome inhibition by substrate micro-flora other than *A. bisporus* is also considered key to the activity of *T. aggressivum* (Savoie *et al.*, 2001a). The biological conditioning during Phases I and II of substrate production produce a complex diversity of microbes in the substrate which inhibit the growth of many competitor moulds, but not *T. aggressivum* (Largeteau *et al.*, 2000b).

Hyphal coiling and the formation of appressoria like structures is usually associated with mycoparasitism in *Trichoderma* species (Harman *et al.*, 2004). Despite attempts to induce this kind of interaction between *T. aggressivum* and *A. bisporus* it has rarely been observed (Williams *et al.*, 2003b), whereas with other *Trichoderma* species found on mushroom farms it occurs readily *in vitro* (Goltapeh & Danesh, 2000). The absence of hyphal coiling and the ability of *T. aggressivum* to grow in mushroom substrate in the absence of *A. bisporus* have led some researchers to suggest that antagonism of *A. bisporus* by *T. aggressivum* is an example of aggressive competition, rather than true parasitism.

Mushroom substrate contains a limited amount of available nutrients and the objective of mushroom cultivation is to convert as much of these nutrients into *A. bisporus* fruiting bodies as possible. The growth of any microbes which cannot subsequently be digested by *A. bisporus* sequesters some nutrients, reducing the biological efficiency of mushroom production. In biocontrol strains of *Trichoderma* parasitism of plant pathogenic fungi has been described as opportunistic, competitive antagonism (Harman *et al.*, 2004). These species exhibit parasitic behaviour towards a range of fungi but typically obtain most of their nutrition from other sources, suggesting that they use mycoparasitism to maintain their

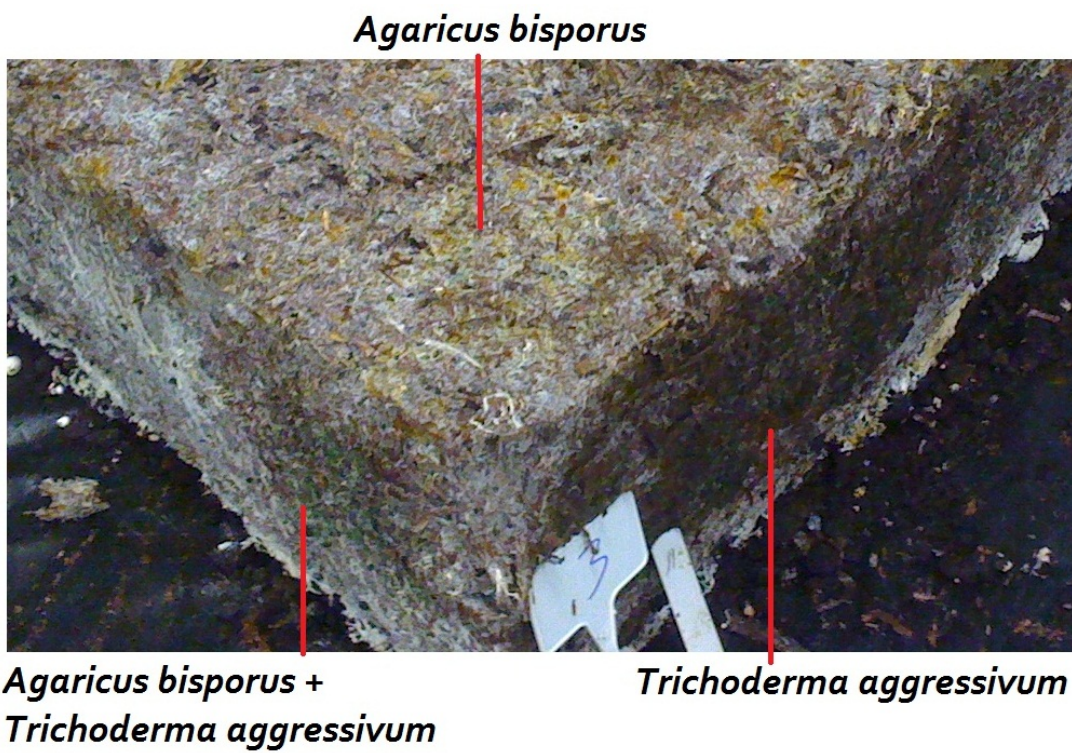

Fig. 1.8: Spent mushroom substrate colonised by *Trichoderma aggressivum* and *Agaricus bisporus*.

place in the rhizosphere free of competitors.

The ability of *T. aggressivum* to grow in mushroom substrate has been attributed to its resistance to inhibition by a greater number of substrate micro-flora (including *A. bisporus*) than *T. harzianum* or *Trichoderma atroviride*, rather than a greater ability to obtain nutrition from the substrate (Largeteau *et al.*, 2000b; Savoie *et al.*, 2001a). Both of *T. atroviride* and *T. harzianum* are facultative mycoparasites and produce metabolites which are more detrimental to *A. bisporus* than those of *T. aggressivum* (Mumpuni *et al.*, 1998). However when *T. harzianum* or *T. atroviride* grow in mushroom substrate colonised by *A. bisporus* the fungi exhibit a level of mutual antagonism towards each other; they do not grow in the same space. This response is typical of many fungi in co-culture, hyphae at the point of contact accumulate toxic metabolites to prevent the growth of the competitor but cannot grow themselves, resulting in a kind of deadlock scenario (Silar, 2005; Verma *et al.*, 2007).

T. aggressivum can colonise a large areas of substrate which also contain *A. bisporus* mycelium before any apparent antagonism becomes evident (Figure 1.8). This situation does not last indefinitely, *T. aggressivum* eventually supplants the *A. bisporus* mycelium although some *A. bisporus* may remain and replace *T. aggressivum* subsequently (Guthrie & Castle, 2006). During interactions between biocontrol strains of *T. atroviride* and fungal plant pathogens the majority of genes upregulated in *T. atroviride* are involved in the cellular stress response, more so than those involved in attacking the host (Seidl *et al.*, 2009). *T. aggressivum* produces metabolites less toxic towards *A. bisporus* than *T. atroviride* but it may have a similar system for detoxifying metabolites of *A. bisporus* which allows the two fungi to grow in the same area without inhibiting each other.

During vegetative growth *A. bisporus* degrades lignin in the substrate, this increases the bioavailability of holocellulose (ten Have *et al.*, 2003). During fruiting body formation the metabolism of cellulose and hemi-cellulose by *A. bisporus* is increased (Durrant *et al.*, 1990). *Trichoderma reesei* is known for its ability to degrade ligno-cellulosic substrates but obtains most of its nutrition from cellulose derivatives liberated by the breakdown of lignin than from the lignin itself (Kubicek *et al.*, 2011; Martinez *et al.*, 2008). If *T. aggressivum* exhibits a similar preference for cellulose as a nutrient source, then the secretion of lignin degrading

enzymes by *A. bisporus* may provide a food-source for *T. aggressivum*. The two fungi may occupy different ecological niches in the substrate environment, one primarily decomposing lignin and the other utilising more easily available carbon sources, with limited interaction. Nutrient limitation may then induce the opportunistic antagonistic side of *T. aggressivum*, causing it to become antagonistic toward *A. bisporus*.

Chitinase production has been linked to the antagonistic effect of *T. aggressivum* on *A. bisporus* (Guthrie & Castle, 2006) and chitinase production in other *Trichoderma* species is linked to starvation. Under nutrient limiting conditions *T. aggressivum* may produce chitinase and other metabolites which harm *A. bisporus* in order to remove competition or to obtain additional nutrition. Without the ability to obtain nutrients from the more recalcitrant components of the substrate such as lignin *T. aggressivum* may then lose its selective edge and be displaced by *A. bisporus* mycelium moving in from unaffected areas of substrate.

1.5.4 Epidemiology and spread

The epidemiology of *Trichoderma aggressivum* is a complex, multifactorial problem. Researchers have described the activities of *T. aggressivum* in laboratory and farm scale experiments and in industry (Grogan *et al.*, 1996; Seaby, 1996b; Chen *et al.*, 1999b; Royse *et al.*, 1999; Rinker & Alm, 2000; Beyer *et al.*, 2000). Results sometimes vary between researchers as the conditions and materials used in mushroom production worldwide vary considerably and *T. aggressivum* infection can progress differently *in vitro* than in a larger scale.

In the mushroom industry there is usually a delay between the time of infection and the first observation of symptoms, which can make pin-pointing the point of entry difficult. The severity of infection can depend upon the point at which *T. aggressivum* is introduced, the type of spawn used, compost quality and probably the subspecies and strain of *T. aggressivum* in question, all of which vary between producers and over time. These factors can complicate investigations into the epidemiology of *T. aggressivum*.

1.5.5 Points of entry

The presence of *T. aggressivum* on the raw materials for Phase I of substrate production and ineffective pasteurisation during Phase II has been proposed as one avenue of entry for the microbe (Seaby, 1996b). The incidence of *Trichoderma* green mould is generally higher in crops grown on unpasteurised substrate (Danesh *et al.*, 2000). Reports vary on the susceptibility of *T. aggressivum* to heat treatment; *in vitro* test have shown that 60 °C for 9 hr is sufficient to kill *T. aggressivum* (Morris *et al.*, 2000), other researchers state that *T. aggressivum* can often survive industry standard pasteurisation to some extent (Beyer *et al.*, 2000; Rinker & Alm, 2000). A recent report showed that while standard pasteurisation at 60 °C for 12 hr will reduce *T. aggressivum* to undetectable levels, but reduction in the temperature to 57 °C and time to 8 hr makes pasteurisation considerably less effective (Grogan *et al.*, 2012). Local temperature fluctuations in the order of a few degrees within a large mass of substrate are conceivable, so it may be the case that sub-optimal pasteurisation could lead to a reduction, rather than removal of *T. aggressivum* from the substrate which may not become apparent until the later stages of production, when *T. aggressivum* proliferates.

Spawning has been described as a prime point for infection of substrate by *T. aggressivum*. The spawning process necessitates access to the substrate which may allow transmission of *T. aggressivum* on workers and equipment (Rinker & Alm, 2000). The spawn itself may present a source of easily available carbohydrate to give *T. aggressivum* a foothold in the substrate (Fletcher, 1997) and colonisation of the spawn grains before the outgrowth of *Agaricus bisporus* is likely to have severe impact on the crop. Infection of substrate at spawning has been shown to reduce yields considerably more than after the substrate is colonised by *A. bisporus* (Rinker, 1997; Beyer *et al.*, 2000) so the exclusion of *T. aggressivum* from this process is a high priority for mushroom producers. Contamination of the spawn itself with *T. aggressivum* has been blamed for the introduction of the fungus, although considering the level of sanitation used in the production of spawn this seems unlikely.

In *in situ* spawn run systems the possibility of introducing *T. aggressivum* after spawn run is minimal (Seaby, 1996b). Contamination of the casing or

upper layer of compost can lead to superficial infections which reduce yield by a relatively small amount. Emergence of severe green mould symptoms after casing may occur as a result of infection at spawning with low levels of visible sporulation. In the Bulk Phase III system bulk handling of substrate during the emptying of Phase III tunnels, transport to the grower and filling offer an additional opportunity for *T. aggressivum* to gain access to the substrate. There is currently little information regarding infection of crops at this point and it is assessed in part in Chapter 4 of this work.

On farms where *T. aggressivum* is a problem it tends to persist. Seaby (1996b) described lagoon water, dust debris and equipment as prime sources of *T. aggressivum* infection. Infected material can be spread on workers clothing and equipment (Royse *et al.*, 1999) so separation of workers from areas where spore loads are high (such as emptying of SMS) and areas susceptible to infection (such as spawning) is crucial (Rinker & Alm, 2000).

Insect and arthropod pests have been linked to the spread of *Trichoderma aggressivum* (Seaby, 1996a). Mites of the genus *Pygmephorus* are sometimes associated with *T. aggressivum* infection and can become vectors for the transmission of infection (Seaby, 1996b). Sciarid and phorid flies are associated with mushroom production (Jess *et al.*, 2007). They are a problem in and of themselves and transmit disease-causing fungi such as *Verticillium fungicola* (Shamshad *et al.*, 2009) so they may also transmit *Trichoderma* spores. The Bulk Phase III system reduces the risk of *Trichoderma* spread on arthropod vectors in general as spawn-run is separated from later stages of production, where flies and mites are more common.

Contamination during the cropping cycle typically leads to less severe infection than at spawning. However, as *T. aggressivum* is capable of colonising substrate and casing previously colonised by *A. bisporus* (Largeteau *et al.*, 2000b) infection early in the cropping cycle will become increasingly severe with each flush. Spent mushroom substrate can contain very high levels of disease-causing organisms and special considerations must be taken in its disposal.

1.5.6 Treatment and control

Fungicides can be used to control the growth of *Trichoderma aggressivum*. Direct application of carbendazim to mushroom spawn reduces the risk of infection at spawning (Grogan *et al.*, 1996). Prochloraz, carbendazim, benomyl and thiabendazol reduce the level of substrate colonisation by *T. aggressivum* (Abosriwil & Clancy, 2004). Benomyl, chlorothalonil, thiabendazole and thiophanate methyl reduce the level of casing colonisation (Rinker & Alm, 2008).

The number of fungicides approved for use in mushroom production varies between countries, in the EU the number is becoming increasingly small. There have also been reports of *T. aggressivum* strains resistant to fungicides (Romaine *et al.*, 2008). These factors have prompted research into alternatives to fungicides for the control of *T. aggressivum* such as spawn strain resistance (Anderson *et al.*, 2000), plant essential oils (Regnier *et al.*, 2012) and biological control (Györfi & Geösel, 2008).

Currently, rigorous hygiene is considered the best method for prevention of *T. aggressivum* infection. Steam cook-out after every crop and use of disinfectant on surfaces and equipment are now standard practice for reducing spread of all mushroom diseases. Physical separation of the different stages of production reduces the chance of material being transferred from the latter stages of cropping (where disease levels may be high) and those in the earlier stages (which are more vulnerable to infection) (Rinker & Alm, 2000; den Ouden, 2012). The use of any chemical agent to deal with *T. aggressivum* adds to the cost of mushroom production as well as raising food safety and resistance issues. A rigorously applied hygiene management system can reduce the occurrence of all mushroom diseases, not just *T. aggressivum*.

1.6 Aims and Objectives of this Study

The overall objectives of this study were:

- To investigate the reaction of *Trichoderma aggressivum* to *Agaricus bisporus* tissue and to mushroom substrate using a proteomic approach.
- To study the effect of bulk handling on *T. aggressivum* infected mushroom substrate and its epidemiology in the Bulk Phase III mushroom system.
- To compare and evaluate methods for the detection and quantification of *T. aggressivum* in Bulk Phase III mushroom substrate.
- To develop a method for the identification of *T. aggressivum* using real-time PCR with novel selective primers.
- To assess HPLC profiling of secondary metabolites as a method of differentiating *T. aggressivum* from other *Trichoderma* species.

2. MATERIALS AND METHODS

All chemicals apart from enzymes were purchased from Sigma-Aldrich Limited unless otherwise noted. Enzymes were purchased from Promega unless otherwise noted.

2.1 *Fungal cell culture*

2.1.1 *Culture media*

Malt extract agar (MEA)

Malt extract agar (25 g) or 10 g each of malt extract and agar (technical grade) were added to 500 ml of distilled water and autoclaved at 115 °C for 10 min. The liquid agar was allowed to cool to ~55 °C and aseptically transferred into sterile plastic Petri dishes (~20 ml agar per dish) in a laminar flow hood. The medium was allowed to cool for 1 hr and either stored at 4 °C or used immediately.

Trichoderma minimal medium (TMM)

Ammonium tartrate (0.5 g), MgSO₄ (0.1 g), K₂HPO₄, KCl (0.08 g) and glucose (5 g) were dissolved in distilled water (500 ml). Agar (7.5 g) was added and the medium was sterilised by autoclaving at 121 °C for 15 minutes. The liquid agar was allowed to cool to ~55 °C and aseptically transferred into sterile plastic Petri dishes (~20 ml agar per dish) in a laminar flow hood. The medium was allowed to cool for 1 hr and either stored at 4 °C or used immediately. Adapted from (Williams *et al.*, 2003a).

Malt extract agar/ streptomycin sulphate (MEAS)

Malt extract agar was prepared as above. After cooling the sterile agar to ~ 55 °C and prior to dispensation into Petri dishes streptomycin sulphate stock solution (1 ml per 100 ml) was added. The final concentration of streptomycin sulphate in the medium was 10 ppm.

Ohio agricultural experimental station medium (OAES)

Glucose (5 g), yeast extract (2 g), sodium nitrate (1 g), magnesium sulphate (0.5 g), potassium phosphate monobasic (1 g), dessicated ox bile (1 g) and sodium propionate (1 g) were dissolved in 1 L distilled water. Agar (15 g) was added and the medium was sterilised by autoclaving at 121 °C for 15 minutes. The molten agar was kept at 55 °C until use and streptomycin sulphate stock solution (1 ml per 100 ml) was added. Adapted from (Kaufman *et al.*, 1963).

Streptomycin sulphate stock solution

Streptomycin sulphate was dissolved as a 1 % w/v solution in autoclave sterilised water in a sterile container under aseptic conditions. The solution was stored at 4 °C for up to 1 month.

Malt extract broth

Malt extract was dissolved in distilled water as a 1% or 2 % w/v solution. The solution was transferred to 250 ml conical flasks in 100 ml volumes and sealed with cotton-wool and tinfoil prior to autoclaving at 115 °C for 10 min. Sterile broth was stored in the autoclaved containers at room temperature for up to 4 days.

Malt extract broth with Bulk Phase III mushroom substrate

Bulk Phase III mushroom substrate was obtained from Carbury compost Ltd at end of spawn run and lyophilised. Lyophilised bulk Phase III mushroom substrate (1 g) was added to malt extract (1 g) and 100 ml distilled water in a 250 ml conical

flask, sealed with cotton wool and covered with tinfoil. The medium was sterilised by autoclaving at 115 °C for 10 minutes and stored at room temperature.

Malt extract broth with Agaricus bisporus cap tissue

Closed sporocarps of *Agaricus bisporus* were obtained from Barretstown Farm Ltd. Caps were finely chopped and the tissue (1 g) was added to malt extract (1 g) and 100 ml distilled water in a 250 ml conical flask, sealed with cotton wool and covered with tinfoil. The medium was sterilised by autoclaving at 115 °C for 10 minutes and stored at room temperature.

2.1.2 Sterile water

Distilled water was autoclaved at 121 °C for 15 min, sealed tightly and stored at room temperature.

2.1.3 Strain maintenance and reference isolates

Trichoderma aggressivum reference isolates were acquired from Centraalbureau voor Schimmelcultures (CBS, Royal Netherlands Academy of Arts and Sciences, Utrecht, the Netherlands) and were added to the National University of Ireland, Maynooth culture collection under liquid nitrogen. Additional *Trichoderma* strains were retrieved from long term storage at -70 °C in the Teagasc Kinsealy culture collection. A list of *Trichoderma* isolates used in this work is given in Table 2.1.

Primary cultures were inoculated onto MEA from long term storage and grown for three days at 20 °C before being used to inoculate secondary cultures for experimental work. Subcultures were performed every 6-8 weeks but no more than three secondary subcultures were performed before retrieving a fresh primary culture from storage.

2.1.4 Long term strain storage

Trichoderma isolates were cultured on MEA at 20-25 °C with periodic illumination for 5 days to promote of sporulation. Plugs (5 mm diameter) were excised from the growing edge of the culture and added to cryotubes containing 1 ml 60

Tab. 2.1: *Trichoderma* isolates used in this work.

Code	Classification	Source
100526	<i>T. aggressivum</i> f. <i>europaeum</i>	CBS
433.95	<i>T. aggressivum</i> f. <i>europaeum</i>	CBS
K417	<i>Trichoderma aggressivum</i> biotype Th2	AFBI Loughall
FM 2	<i>Trichoderma harzianum</i> biotype Th1	FERA
FM 5	<i>Trichoderma harzianum</i> biotype Th1	FERA
FM 10	<i>T. aggressivum</i> f. <i>europaeum</i>	FERA
FM 11	<i>T. aggressivum</i> f. <i>europaeum</i>	FERA
FM 18	<i>T. aggressivum</i> f. <i>europaeum</i>	FERA
K387	<i>Trichoderma aggressivum</i> biotype Th2	Teagasc Kinsealy
K363	<i>Trichoderma</i> sp.	Teagasc Kinsealy
355	<i>Trichoderma atroviride</i>	Teagasc Kinsealy
T. atro	<i>Trichoderma atroviride</i>	Teagasc Kinsealy
413	<i>Trichoderma</i> sp.	Teagasc Kinsealy
433	<i>Trichoderma</i> sp.	Teagasc Kinsealy
430	<i>Trichoderma harzianum</i>	Teagasc Kinsealy
K517	Non-aggressive <i>Trichoderma</i> sp.	Poland
K516	Non-aggressive <i>Trichoderma</i> sp.	Poland

% (v/v) autoclave sterilised glycerol (3 plugs per tube). Cryotubes were stored at -70 °C and/or in liquid nitrogen.

2.1.5 Liquid culture of *Trichoderma* isolates

Plugs (5 mm diameter) were cut from the growing edge of *Trichoderma* mycelium cultured on malt extract agar for 3 days at 25 °C. Plugs were aseptically transferred to 100 ml of sterile liquid growth medium and incubated in the dark at 25 °C on a shaking incubator at 100 rpm.

2.1.6 Liquid culture of *Trichoderma aggressivum* with *Agaricus bisporus* tissue and Bulk Phase III mushroom substrate

Malt extract broth (1 %, control), malt extract broth with Bulk Phase III mushroom substrate and malt extract broth with *Agaricus bisporus* cap tissue were inoculated with *Trichoderma aggressivum* strain CBS 100526 as per section 2.1.5 and cultured for 7 days.

2.1.7 Colony counting methods

All colony counting procedures were carried out in a class 2 biological safety cabinet under aseptic conditions. All incubations were carried out at 25 °C in the dark. For full weed mould analysis and most probable number analysis one plate per sample showing growth of *Trichoderma* was retained and the species was confirmed as *Trichoderma aggressivum* by PCR. In some experiments where counts were performed on *T. aggressivum* infected mushroom substrate corresponding mushroom substrate subsamples were sent to FERA, UK for q-PCR testing.

Full weed mould analysis

Mushroom substrate subsamples (20 g) were mixed with sterile water (200 ml) in a polythene bag using a BagMixer 400 R (Interscience) stomacher at 100 cycles per minute for 1 minute, left stand for 5 minutes and mixed for a further 1 minute. The homogenised compost extract was then serially diluted from 10^{-1} - 10^{-9} in sterile water and 1 ml subsamples were added to plastic Petri dishes in duplicate. Molten OAES medium (\sim 20 ml) which had been cooled to \sim 55 °C was added to the Petri dishes. The extract was mixed with the agar by gentle swirling and allowed to set. OAES plates were incubated for 2 days and *Trichoderma* colonies were counted on plates showing 20-200 colonies. The count was repeated 1 day later. The initial fungal load in the compost was calculated in terms of cfu/g fresh weight by multiplying the mean number of colonies observed by the dilution factor of the extract used (the neat extract had a dilution factor of 10).

Most probable number (MPN) analysis

Homogenized compost extract was prepared as per full weed mould analysis and a dilution series was prepared in the range of 10^{-1} - 10^{-6} . Five 10 μ l drops of diluted compost extract were spotted onto MEAS plates, distributed evenly. Plates were incubated for 3 days and each plate was scored for the number of drops showing growth of *Trichoderma aggressivum*. The count was repeated after a further 2 days incubation. The total score was measured for each dilution level and the initial fungal load in the compost was estimated in terms of cfu/g fresh weight by using the MPN method (Halvorson & Ziegler, 1933; Briones *et al.*, 1999; Herigstad *et al.*, 2001).

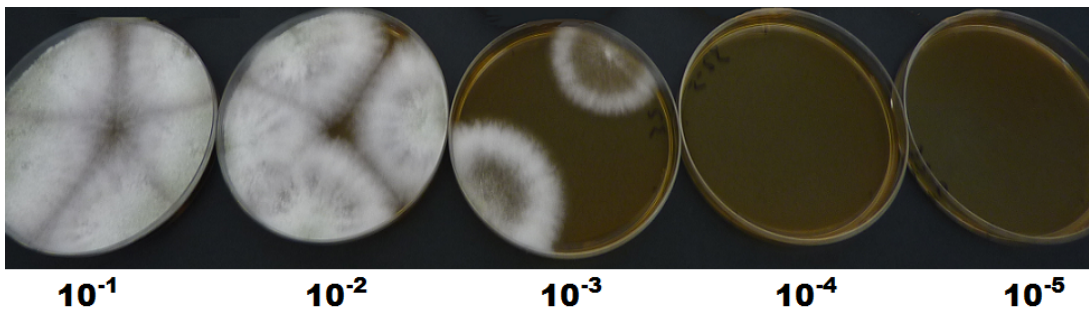

Fig. 2.1: Example of results of most probable number assay
Test performed on a single substrate subsample serially diluted 5 times and plated.

Direct plating assessment

Individual straws of mushroom substrate were removed from a thoroughly mixed subsample of mushroom compost and cut to approximately 3 cm in length using sterilised forceps and scissors. Cut straw pieces (10 per sample) were placed aseptically onto 140 mm diameter MEAS plates and incubated for 2-4 days. The amount of *T. aggressivum* in the substrate was scored based on the number of compost pieces from which growth of *Trichoderma* was observed. The plates were re-incubated and recounted after a total of 7 days.

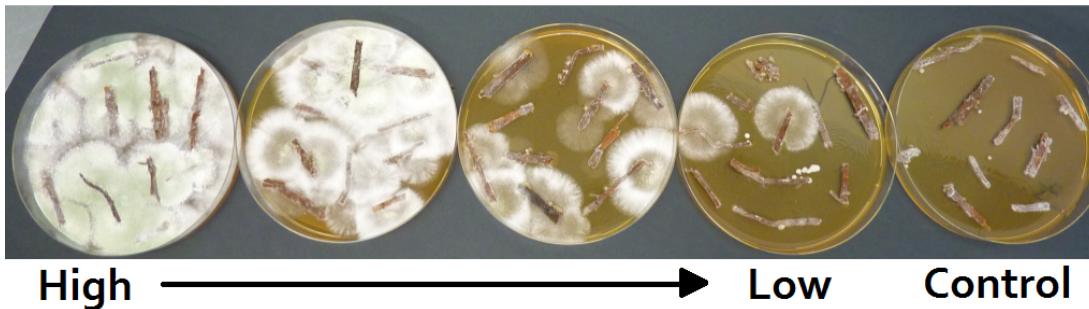

Fig. 2.2: Example of results of a direct plating assay.

Trichoderma aggressivum mycelium is visible growing from more straws in substrate infected at higher levels. No growth is observed from the control substrate.

2.1.8 Culture waste disposal

Used agar plates, liquid media and all gloves and other non-sharp materials which were used in microbial culture were autoclave sterilised at 130 °C for 30 minutes. Contaminated sharps were disposed of in a contaminated sharps bin and destroyed by incineration.

2.2 Proteomic reagents

2.2.1 Protein extraction buffer

Protein extraction buffer was prepared by adding 1 µl/ ml of a 10 mg/ ml solution of the protease inhibitors pepstatin A, TLCK, leupeptin and aprotinin to cell homogenisation buffer (Section 2.6.2).

2.2.2 10X sample buffer

SDS (2 g), DTT (1.54 g), Bromophenol Blue (2 ml), 50 % (w/v) sucrose solution (2 ml), 3 M Tris-HCl (2.1 ml, pH 6.7) and 200 mM EDTA (0.5 ml, pH 7.0) were added to a disposable 15 ml falcon tube and the volume was adjusted to 10 ml with Milli-Q water (3.4 ml). The buffer was stored at -20 °C as 500 µl aliquots.

2.2.3 10 % w/v APS solution

APS (1 g) was added to Milli-Q water (10 ml) in a sterile 15 ml Falcon tube and allowed to dissolve at room temperature. The solution was stored at -20 °C as 1 ml aliquots.

2.2.4 10 % w/v SDS solution

SDS (10 g) was added to Milli-Q water (100 ml) and dissolved at room temperature with constant stirring. The solution was stored at room temperature. Note: as SDS is highly irritating to the eyes and respiratory tract it must be weighed in a fume cabinet or appropriate PPE must be worn to prevent exposure to dust.

2.2.5 SDS-PAGE running buffer

10X SDS-PAGE running buffer was prepared by dissolving Tris-base (30.2 g/L), SDS (10 g/L) and glycine (144 g/L) in Milli-Q water with constant stirring. The pH of the buffer was adjusted to 8.9 if necessary. Prior to use the buffer was diluted 10:1 for a final concentration of 25 mM Tris, 0.1 % (w/v) SDS and 192 mM glycine.

2.2.6 Iso-electric focusing (IEF) buffer

Urea (48 g), Triton X100 (1 ml), CHAPS (4 g), Tris-HCL (0.158 g) and Thiourea (15.22 g) were added gradually to an initial volume 20 ml Milli-Q water with constant stirring. After all solutes had dissolved the final volume was adjusted to 100 ml with Milli-Q water for a final concentration of 8 M Urea, 1 % (v/v) Triton X100, 4 % (w/v) CHAPS, 10 mM Tris-HCL and 2 M Thiourea. It is necessary to start with a small initial volume of water as the urea increases the volume of the solution as it dissolves. The IEF buffer was stored at -20 °C in 2 ml aliquots.

2.2.7 IEF equilibration buffer

Glycerol (150 ml), SDS (10 g), Urea (180.18 g) and Tris-base (3.94 g) were added to 350 ml Milli-Q water with constant stirring. The pH of the solution was

adjusted to pH 6.8 prior to adjusting the volume to 500 ml with Milli-Q water. The buffer was stored at -20 °C as 40 ml aliquots.

2.2.8 *Polyacrylamide gels*

1-D Separating gel (12.5 %)

Sufficient separating gel to cast two 1-D gels was prepared by adding Protogel (5 ml), 1.5 M Tris-Base (3 ml, pH 8.8), 10 % SDS (120 µl), 10% APS (75 µl) and TEMED (3 µl) to Milli-Q water (3.8 ml). APS solution and TEMED were added immediately before mixing and pouring the gel as they cause the mixture to begin to set.

1-D Stacking gel (5 %)

Sufficient stacking gel to cast two 1-D gels was prepared by adding Protogel (830 µl), 0.5 M Tris-HCL (630 µl, pH 6.8), 10 % w/v SDS (50 µl, 10 % APS (50 µl) and TEMED (5 µl) to Milli-Q water (3.4 ml). APS solution and TEMED were added immediately before mixing and pouring the gel as they cause the mixture to begin to set.

2-D Separating gel

To prepare 4 gels Protogel (100 ml), 1.5 M Tris (60 ml, pH 8.8), 10 % SDS (2.4 ml), 10 % APS (1.5 ml) and TEMED (60 µl) were added to Milli-Q water (76 ml). APS solution and TEMED must be added immediately before mixing and pouring the gel.

2.2.9 *Agarose sealing solution*

Molecular biology grade Agarose (1 g) and bromophenol blue (~0.01 g) were added to 1X SDS-PAGE running buffer (100 ml) and heated in a microwave oven until the agarose dissolved. The solution was prepared on the day of use and allowed to cool to ~50 °C before application.

2.2.10 Staining solutions

Coomassie stain

Brilliant blue (2 g) was added to Methanol (450 ml), acetic acid (100 ml) and Milli-Q water (450 ml). The stain was stored at room temperature in a flammables cabinet.

Coomassie destain buffer

Acetic acid (100 ml) and ethanol (200 ml) were added to Milli-Q water (700 ml). The solution was stored at room temperature

Protein fixing solution

Ethanol (500 ml) and phosphoric acid (30 ml) were added to Milli-Q water (470 ml). The solution was stored at room temperature.

Pre-incubation buffer

Ethanol (340 ml), ammonium sulphate (170 g) and phosphoric acid (30 ml) were added to Milli-Q water (630 ml). The solution was stored at room temperature in a flammables cabinet.

2.3 Proteomic methods

2.3.1 Cellular protein extraction

Protein was extracted from *Trichoderma* mycelium grown in liquid culture for 7 days. The whole mycelial mass was filtered through a double layer of autoclaved Miracloth and washed twice with sterile water to remove residual culture medium. The mycelium was then press dried and flash frozen in liquid nitrogen. To lyse cells mycelium (4 g fresh weight) was ground to a fine powder using an autoclaved mortar and pestle which had been cooled with liquid nitrogen. Protein extraction buffer (4 ml) was added to the powder and allowed to freeze (additional liquid nitrogen was added at this point if the buffer did not freeze readily). The mycelium was then ground further until the homogenisation buffer had fully

thawed. Using a wide-bore pipette tip the cell lysate was transferred to 1.5 ml Eppendorf tubes in 1 ml aliquots and centrifuged at 1,000 rcf for 5 minutes at 4 °C. The supernatant containing the protein was transferred to a fresh Eppendorf tube and the pellet discarded.

2.3.2 *Protein quantification by Bradford assay*

Protein extract (20 µl) prepared as per Section 2.3.1 was added to pre-diluted (1/5) Biorad protein assay reagent to (980 µl) in a 1 ml plastic cuvette. Absorbance at 595 nm was measured using an Eppendorf Biophotometer and protein concentration was determined using standard curve of range of 100 µg/ml to 1,500 µg/ml calibrated using BSA standard (M.M., 1976).

2.3.3 *Acetone precipitation of proteins*

A volume of protein extract containing the desired quantity of protein was added to 3 volumes of ice cold acetone and incubated at -20 °C for at least one hour. The protein was pelleted by centrifugation at 16,000 rcf for 30 min at 4 °C. The supernatant was discarded and the pellet retained and dried.

2.3.4 *2-Dimensional SDS-PAGE*

Iso-electric focusing

Protein samples were acetone precipitated to give a pellet of 350 µg protein. The protein was resuspended in IEF buffer (250 µl) amended with pH 4-7 ampholytes (2 µl) and DeStreak reagent (1 µl). When fully dissolved the sample was transferred to a porcelain coffin at the negative end and an IPG strip (pH 4-7, 14 cm) was placed on top of it (gel side down) so that the sample became evenly distributed across the length of the strip. Any air bubbles between the strip and the base of the coffin were removed and IPG cover fluid was layered on top of the strip. Iso-electric focusing was carried out according to the protocol in Table 2.2.

Tab. 2.2: Iso-electric focusing protocol for pH 4-7 IPG strips

Cycle Stage	Step Type	Voltage (V)	Time (hr)
1	Step	50	10
2	Step	250	0.25
3	Gradient	8000	5
4	Step	8000	8

Immobiline Drystrip equilibration

After focusing, Immobiline Drystrips were carefully removed from coffins and transferred to clean 20 ml test-tubes. Strips were incubated on a rocker at room temperature in IEF equilibration buffer containing DTT (0.01 g/ml) for 20 minutes and IAA (0.0125 g/ml) for a further 20 minutes. Excess equilibration buffer was removed by dipping the strips in 1X SDS-PAGE running buffer prior to the second dimension of focusing.

Protein separation in the second dimension

Slab gels (12.5 %, 1.5 cm thickness) for 2-D electrophoresis were cast in bulk in a Biorad Protean II multi-gel casting chamber to minimise gel to gel variation. Focused and equilibrated IEF strips were laid on top of the gel and sealed with agarose sealing solution. Gels were run in triplicate for 18 hr at a constant wattage of 1.5 Watts per gel in a Biorad Protean Plus Dodeca-Cell system using 1X SDS-PAGE running buffer at 10 °C.

Colloidal coomassie staining

Gels were carefully removed from between glass plates and incubated in fixing solution (200 ml/ gel) in a sealed plastic container for a minimum of 3 hours on an orbital shaker at 40 rpm at room temperature. Gels were washed 3 times in Milli-Q water and transferred to pre-incubation buffer for 20 min under the same conditions as above. Serva blue powder (0.5 g/100 ml) was added to the pre-incubation buffer and the gels were left to stain for 7 days. After this period

the gels were transferred to a clean plastic container and destained by rinsing with Milli-Q water until no colloidal Serva remained.

2.3.5 *Image acquisition and analysis*

Stained proteins were visualised on an Epson ImageScanner III (Epson (UK) Ltd., Westside London Road, Hemel Hempstead, Hertfordshire, UK) and scanned as transparencies at 16 bit, 600 dpi, greyscale. This method was determined empirically to be the optimum on the basis of maximising bit depth and resolution without introducing saturation or producing files of unmanageable size.

Images were analysed using Progenesis same spots software version 3.3 (Non-linear Dynamics). All experimental gels were aligned to a reference gel and spots were detected and filtered. Images were then separated into treatment groups, with 3 replicate gels per group and spots were analysed to determine significant changes between treatments by densitometry and one-way ANOVA analysis. Spots with p value scores lower than 0.05 were taken to have changed significantly in expression and were analysed by LC/MS.

2.4 *Mass spectrometry*

2.4.1 *Reagents*

All solutions used in these procedures made up in HPLC grade solvents and were prepared on the day of use unless otherwise noted.

Ammonium bicarbonate solution (100 mM)

Ammonium bicarbonate (0.3953 g) was dissolved in water (50 ml).

Spot destain buffer

Ammonium bicarbonate solution (5 ml, 100 mM) was added to HPLC grade water (5 ml).

Formic acid solution (5 % v/v)

Formic acid (1 ml) was added to water (19 ml).

Peptide extraction buffer

Formic acid solution (3 ml, 5 % v/v) was added to acetonitrile (6 ml).

Peptide resuspension buffer

Formic acid solution (0.1 ml, 5 % v/v) was added to water (4.9 ml).

Trypsin reconstitution buffer

Acetonitrile (1 ml) was added to 10 mM ammonium bicarbonate (1 ml) and water (8 ml).

Trypsin solution

Sequencing grade trypsin (Promega) was reconstituted in trypsin reconstitution buffer (1 ml) and stored at -20 °C. The final concentration of trypsin was 13 ng/μl.

LC-MS buffer A

Formic acid (1 ml) was added to water (1 L) and stored at room temperature.

LC-MS buffer B

Formic acid (1 ml) was added to acetonitrile (900 ml) and water (100 ml). The solution was stored at room temperature.

2.4.2 Sample preparation for mass spectrometry

Individual protein spots were manually excised, transferred to sterile Eppendorf tubes (1.5 ml) and destained with spot destain buffer (100 μl) by incubation at room temperature for 30 minutes. Spot destain buffer was removed, acetonitrile (500 μl) was added and the plugs were incubated at room temperature until they had become dehydrated (up to 30 min). The acetonitrile was removed and reconstituted trypsin (50 μl) was added to the plug followed by overnight incubation at 37 °C. Peptide extraction buffer (100 μl) was added and the samples were incubated at 37 °C for 10 minutes. The supernatant was removed and

lyophilised in a vacuum centrifuge. Lyophilised peptides were stored at -20 °C until the day of analysis. Peptide resuspension buffer (20 µl) was added and samples were sonicated for 10 min. Resuspended peptides were passed through a 0.22 µm filter and transferred to autosampler vials (Shevchenko *et al.*, 2006).

2.4.3 LC-MS analysis of trypsin digested proteins

Trypsin digested peptides were separated on an Agilent 1200 series nanoflow liquid chromatograph and analysed with an Agilent 6340 series ion trap mass spectrometer. Capillary voltage was set to 1800 V with a constant capillary flow rate of 2 µl/ min. The mobile phase consisted of water and 90 % acetonitrile both containing 0.1 % v/v formic acid. Sample injection size was 5 µl. Compounds were generated from the obtained spectra using Agilent software and exported as Mascot generic (.mgf) files. Protein homologies were obtained by performing Mascot MS/MS Ion Search (Matrix Science, London, UK) of the NCBI nr and SwissProt databases under the parameters listed in Table 2.3.

Tab. 2.3: Search parameters for Mascot searches

Enzyme	Trypsin
Missed cleavages	Up to two
Fixed modifications	Carboxymethyl (C)
Variable modifications	Oxidation (M)
Peptide tolerance	2 Da
MS/MS tolerance	1 Da
Peptide charge	1+, 2+ and 3+
Precursor m/z	n/a
Instrument	ESI-TRAP

2.5 Mushroom cropping experiments

Cropping experiments were performed at the Teagasc Kinsealy mushroom research unit under standard mushroom growing conditions. Bulk Phase III and

pre-spawned Phase II mushroom substrate were purchased from Carbury Compost Ltd. (Kildare, Ireland) or Kaybeyun compost Ltd. (Monaghan, Ireland). Mushroom substrate supplement (Nutrigain [®]) was obtained from Carbury Compost Ltd. The details of the methods are closely related to the experimental design and so are described in a separate experimental section in Chapter 4 (Section 4.2).

2.5.1 *Statistical analysis*

Statistical analysis was carried out using GraphPad Prism 5. Data were checked for normality using Lilliefors's test prior to applying parametric analysis. Mushroom yield data was analysed by 2 way ANOVA. Colony count and qPCR data was tested using Pearson's correlation test with 2 tailed P values and a confidence interval of 95 %.

2.6 *Molecular biology methods*

Filtered pipette tips were used in all DNA extraction and manipulation procedures to prevent cross-contamination between samples. Set-up for PCR and real-time PCR were carried out in a laminar flow hood. All procedures involving ethidium bromide were carried out with extreme care on a designated ethidium bromide workbench and all waste generated was disposed of in an ethidium bromide waste bin.

2.6.1 *DNA extraction methods*

Manual DNA extraction by salt precipitation

DNA was extracted from *Trichoderma aggressivum* mycelium grown in liquid culture (Section 2.1) according to the method of Aljanabi & Martinez (1997). In brief: *Trichoderma aggressivum* mycelium was removed from liquid culture and filtered through 2 layers of autoclaved Miracloth. The mycelial mass was washed with sterile water and snap frozen in liquid nitrogen. Frozen mycelium (4 g) was added to liquid nitrogen in a sterile mortar and ground into a fine powder. Cell homogenisation buffer was added and the frozen mixture was ground until

it thawed. Aliquots (0.4 ml) were removed from the mortar, transferred to 1.5 ml Eppendorf tubes. Proteinase K (8 μ l; 20 mg/ml) and 20% SDS (40 μ l) were added and tubes were incubated at 55 °C for 1 hr, if RNA contamination was expected RNase A (10 μ l) was added at this point. Saturated sodium chloride (300 μ l) was added and samples were vortexed, then centrifuged at 10,000 rcf for 30 min. The supernatant was transferred to a fresh tube with an equal volume of ice cold isopropanol and incubated at -20 °C for 1 hr. DNA was pelleted by centrifugation at 10,000 rcf for 20 min (4 °C), washed with 70 % ethanol (1 ml), resuspended in nuclease free water (100 μ l) and stored at -20 °C.

Qiagen Plant Dneasy spin kit

DNA was extracted from *Trichoderma* mycelium grown in liquid culture (Section 2.1) according the manufacturer's protocol. The whole mycelial mass was filtered through 2 layers of autoclaved Miracloth, washed with sterile water and ground in liquid nitrogen. A \sim 200 mg subsample of ground mycelium was transferred to 1.5 ml Eppendorf tube for DNA extraction. All buffers and reagents were supplied with the kit, apart from molecular grade ethanol.

Sigma Plant genomic DNA extraction kit

DNA was extracted from *Trichoderma* mycelium grown in liquid or solid culture (Section 2.1) according to the manufacturers protocol. For liquid cultures the whole mycelial mass was filtered through 2 layers of autoclaved Miracloth, washed with sterile water and ground in liquid nitrogen. For solid cultures mycelium was removed from a 3 day culture of *T. aggressivum* with a sterile scalpel, transferred to a 2 ml Eppendorf tube and freeze thawed repeatedly in liquid nitrogen. All buffers and reagents were supplied with the kit, apart from RNase A and molecular grade ethanol.

Promega Wizard Magnetic Food DNA extraction kit

DNA was extracted from *Trichoderma* mycelium grown in liquid culture (Section 2.1) or from liquid spore suspensions of *T. aggressivum* (10^6 spore/ ml) according to the manufacturers protocol. Mycelium was ground in liquid nitrogen before

extraction, spore suspensions were added directly to lysis buffer. All buffers and reagents were supplied with the kit, apart from molecular grade ethanol.

Chemagen Chemagic Food DNA extraction kit

DNA was extracted from *Trichoderma aggressivum* mycelium grown in liquid culture (Section 2.1), from *T. aggressivum* spore suspensions (10^6 spore/ ml) and from lyophilised Bulk Phase III mushroom substrate. The manufacturer's protocol was followed in each case, except that brief vortexing was used for mixing in place of repeated pipetting. Prior to extraction lyophilised mushroom substrate was ground in liquid nitrogen and mixed with a *T. aggressivum* spore suspension (10^6 spore/ g substrate). Mycelium was ground in liquid nitrogen before extraction, spore suspensions were added directly to lysis buffer. All buffers and reagents were supplied with the kit, apart from molecular grade ethanol.

ZR Fungal/ Bacterial DNA extraction kit

DNA was extracted from *Trichoderma aggressivum* mycelium grown in liquid culture (Section 2.1) according to the manufacturer's protocol. All buffers and reagents were supplied with the kit.

2.6.2 Cell homogenisation buffer

NaCl, Tris-base and EDTA were dissolved in nuclease free water to concentrations of 1 M, 0.1 M and 0.1 M respectively in separate sterile 50 ml falcon tubes. Tris-Base and EDTA solutions were both adjusted to pH 8. Cell homogenisation buffer was prepared by adding 20 ml, 5 ml and 1 ml respectively of these stocks to 24 ml nuclease free water. The final concentration of reagents in the solution was 0.4 M NaCl, 10 mM Tris and 2 mM EDTA.

2.6.3 TAE buffer

A 50X solution of TAE was prepared by adding Tris-base (242 g), to acetic acid (57 ml) and of 0.5 M EDTA (100 ml, pH 8.0) and filling to 1 L with Milli-Q water. The solution was autoclaved and stored at room temperature. Prior to use 50X

TAE was diluted to 50:1 with Milli-Q water for a final working concentration of 40 mM Tris, 20 mM acetic acid and 1 mM EDTA.

2.6.4 *Determination of DNA concentration by UV absorbance*

DNA concentration was measured using a NanoDrop 1000 spectrophotometer. Samples were kept on ice and 2 μ l aliquots were removed, placed on the pedestal of the spectrophotometer and absorbance was measured. Blank measurements were performed using either nuclease free water or elution buffer in place of sample, depending on the extraction protocol. The concentration of DNA in the sample was calculated automatically by the NanoDrop software and samples with an A 260/280 value of 1.8 were taken to contain pure DNA (A 260/280 is the ratio of absorbance at 260 nm to 280 nm).

2.6.5 *DNA gel electrophoresis and visualisation*

Agarose (1.5 g) was added to 1X TAE (100 ml) and heated in a microwave oven until the agarose dissolved. The solution was allowed to cool to a handleable temperature before adding ethidium bromide solution (1 μ l, 100 mg/ml) and casting gels with 20 μ l wells. Genomic DNA or PCR product were mixed with 6X gel loading dye and 10-20 μ l was loaded into the wells of the gel. Electrophoresis was carried out in a using 1X TAE buffer at 60 V for 10 minutes followed by 80 V for 20 minutes. The DNA was visualised and images were captured on a G-box using UV transillumination and an ethidium bromide lens filter.

2.6.6 *Endpoint PCR using Sigma Accutaq*

Reactions were carried out in 200 μ l PCR tube (nuclease and nucleic acid free) with a reaction volume of 20 μ l containing 10X LAB Buffer (2 μ l), 10 mM dNTP mix (1 μ l), DMSO (0.4 μ l), 20 μ M forward primer (0.5 μ l), 20 μ M reverse primer (0.5 μ l), nuclease free water (14.4 μ l), template DNA (1 μ l) and Sigma Accutaq DNA polymerase (0.2 μ l). An Eppendorf Mastercycler was used for temperature control under the parameters listed in Table 2.4 with a lid temperature of 96 °C.

Tab. 2.4: PCR amplification protocol using Sigma AccuTaq

Step	Temperature (°C)	Time (min:sec)	Cycles
Initial separation	94	5:00	1
Amplification	94	0:30	
	55-60	0:30	
	68	0:45	35
Final amplification	68	7:00	1
Cooling	4 °C	Indefinite	1

2.6.7 Endpoint PCR using Bioline 2X Mastermix

Reactions were carried out in a 20 μ l volume containing Bioline 2X mastermix (10 μ l), template DNA (4 μ l), 20 μ M forward primer (0.5 μ l), 20 μ M reverse primer (0.5 μ l) and nuclease free water (5 μ l). Bioline 2X master mix contains gel loading dye so the product can be run on a gel immediately after the completion of the reaction. An Eppendorf Mastercycler was used for temperature control under the parameters listed in Table 2.5 with a lid temperature of 105 °C.

Tab. 2.5: PCR amplification protocol using Bioline Mastermix

Step	Temperature (°C)	Time (min:sec)	Cycles
Initial separation	94	0:30	1
Amplification	94	0:30	
	55-60	0:30	
	72	0:30	30
Cooling	4	Indefinite	1

2.6.8 Quantitative real-time PCR (qPCR)

Real-time quantitative PCR was carried out on a Lightcycler 480 machine (Roche) using SyBr green as the fluorophore. Reactions consisted of template DNA (1 μ l), Bioline SyBr Green 2X Mastermix (5 μ l), forward primer (0.25 μ l), reverse

primer (0.25 μ l) and nuclease free water (3.5 μ l) and were carried out in opaque, white 96 well plates (Roche). PCR was carried out for 35 cycles according to Table 2.6. Quantitation was performed once per cycle and melt curve analysis was performed at the end of the run. Standard curves, efficiency and melt curves were generated using the Roche Lightcycler software version 1.5.0 SP3.

Quantitative PCR instrumentation was funded by Science Foundation Ireland
Grant no.: SFI/07/RFP/GEN/571/EC07.

Tab. 2.6: Real-time PCR cycling parameters

Step	Temperature (°C)	Time (min:sec)	Ramp rate	Cycles	Quantitation
Activation	94	10:00	4.4	1	None
Amplification	94	00:20	4.4	45	None
	55-60	00:15	2.2		None
	72	00:15	4.4		Single
Melt Curve	95	00:05	4.4	1	None
	70	1:00	2.2		None
	95	n/a	0.11		5/°C
Cooling	40	5:00	2.2	1	None

2.6.9 Primers

Details of primers used for real-time PCR are shown in Table 2.7. Primers were purchased from Integrated DNA technologies (Belgium). Existing *Trichoderma aggressivum* selective primers were designed by Chen *et al.* (1999a) (THF+THR) and Warwick HRI (18SInt+THI Int rev). Novel selective primer sets (41+180, 43+199 and 44+199) were designed as described in Section 5.3.

Tab. 2.7: Primers used in this study

Name	Primer sequence	Orientation	Tm (°C)
THF ¹	CGGTGACATCTGAAAAGTCGTG	Forward	56.1
THR ¹	TGTCACCCGTTCCGGATCATTCG	Reverse	59.4
18S Int ²	TAACAACACGCCTGCTTAAGA	Forward	54.4
ThI Int rev ²	GAGAAGGCTCAGATAGTAAAAAT	Reverse	50.2
41 ³	TTCGAGAAGGTAAGCGCCAACCTGA	Forward	60.1
180 ³	AATCTTGTGTCGCTGCAAAGGAGG	Reverse	59.6
43 ³	AGAAGGTAAGCGCCAACCTGA	Forward	56.5
199 ³	GCACAAGGAACCCCACTAAA	Reverse	55.3
44 ³	GAGAAGGTAAGCGCCAACCTG	Forward	56.0

¹ *Trichoderma aggressivum* selective primers published by Chen *et al.* (1999a)

² *T. aggressivum* f. *europaeum* selective primers developed by Warwick HRI (Grogan, pers. comm.)

³ Novel selective primers designed targeting the *tef1* gene

2.7 HPLC

All reagents used were of HPLC grade unless otherwise noted.

2.7.1 HPLC extraction buffer

Ethyl acetate, dichloromethane and methanol were mixed in a 3:2:1 ratio. This buffer was stored at room temperature in a flammables cabinet. Formic acid was added to a concentration of 1 % (v/v) immediately prior to use.

2.7.2 HPLC Buffer A

Trifluoroacetic acid (1 ml) was added to water (1 L) in a dark glass container. The solution was prepared on the day of use and stored at room temperature

2.7.3 HPLC Buffer B

Trifluoroacetic acid (1 ml) was added to acetonitrile (1 L) in a dark glass container. The solution was prepared on the day of use and stored at room temper-

ature

2.7.4 Organic extraction of fungal metabolites for analysis by HPLC

For the extraction of fungal secondary metabolites *Trichoderma* cultures were grown on MEA or *Trichoderma* minimal medium at 20 °C for 16 days in the dark. Plugs (5 mm diameter) were then excised from the media at 2.5 mm, 22.5 mm and 42.5 mm from the centre of the dish and transferred to a sterile 1.5 ml Eppendorf tube. HPLC extraction buffer (500 µl) was added to each sample followed by sonication for three 20 minute cycles. The water in the sonication bath being replaced between cycles to prevent excessive heating. The buffer was then removed and transferred to a fresh tube. Plugs were discarded and the buffer containing the extracted metabolites was evaporated overnight in a fume cabinet. The extract was redissolved by sonication for 10 minutes in 90 % methanol, 10 % water (20 µl) and transferred to an autosampler vial for reverse phase HPLC analysis (Smedsgaard, 1997).

2.7.5 Reverse phase HPLC analysis of fungal metabolites

Organic extracts from *Trichoderma* cultures were analysed by reverse phase HPLC (RP-HPLC) on an Agilent 1200 series system with a C-18 RP-HPLC column using diode array detection with multiple wavelengths (210, 230, 254 and 280 nm). Prior to use any gas in the machine was purged by opening the column bypass valve and running 95 % HPLC Buffer A, 5 % HPLC Buffer B through the system at a rate of 5 ml/ min for 5 minutes. The flow rate was reduced to 1 ml/min prior to closing the bypass valve. Blank samples were run through the column prior to loading sample to ensure that any previous samples had been fully eluted. Two HPLC methods were used in this study and a wash step was performed at the end of each run to ensure that there was no crossover of samples between experiments. For all methods column flow rate was constant at 1 ml/min and maximum and minimum pressure tolerances of 400 and 0 bar respectively, standard automated sample injection was performed with a sample size of 10 µl. Table 2.8 and Figure 2.3 show the gradients for each of the methods and the wash step.

Tab. 2.8: HPLC elution methods.

Method 1		Method 2		Wash	
Time	% B	Time	% B	Time	% B
0	5	0	5	0	5
5	5	5	5	5	5
25	100	6	20	15	100
28	30	25	80	20	100
30	5	30	100	35	5
		33	100	40	5
		35	5		
		40	5		

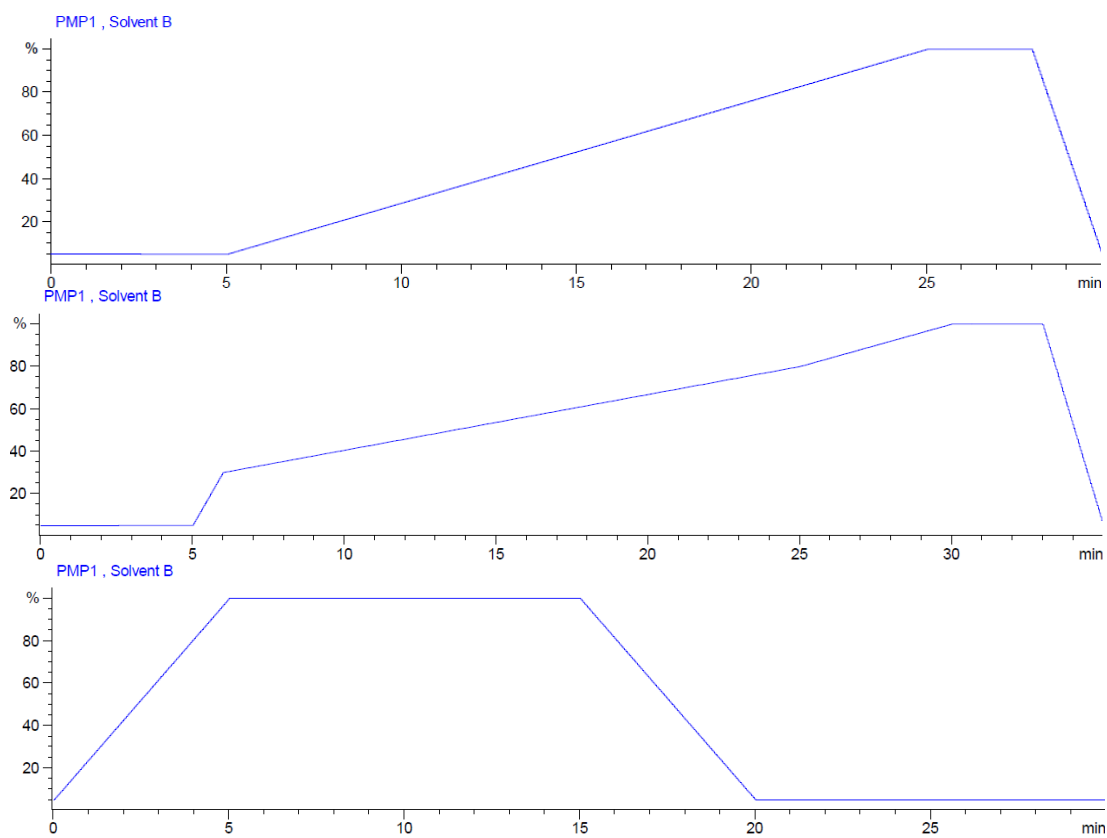

Fig. 2.3: HPLC gradient profiles.

2.7.6 Comparison of metabolite profiles

Metabolite profiles of *Trichoderma* isolate obtained by HPLC were analysed with COWtool (Nielsen *et al.*, 1998). Full unintegrated results for each detector were exported from Agilent Chemstation as .CSV files. For each sample signals from each detector were collated into columns using Microsoft Excel, then transferred to Notepad++. Tabs between signals for each datapoint were replaced with spaces and the spectra were saved as ASCII plain text files. Spectra were opened in COWtool, baseline corrected, log normalised and compared by co-phenetic correlation using the similarity function of COWtool. Reference spectra were prepared from base-line corrected, log normalised spectra using the averaging function of COWtool.

3. CELLULAR PROTEOMICS OF *TRICHODERMA* *AGGRESSIVUM*

3.1 Introduction

Green mould disease of *Agaricus bisporus* is caused by fungi of the genus *Trichoderma* growing in the mushroom substrate and later casing. Green mould disease caused by *Trichoderma aggressivum* causes severe loss of yield whereas other *Trichoderma* species are less harmful.

T. aggressivum was previously classified as a *Trichoderma harzianum* biotype (Samuels *et al.*, 2002). *T. harzianum* is commonly isolated from soil and leaf litter and occasionally occurs in mushroom substrate. *T. aggressivum* has only been reported on mushroom farms, and it has several adaptations which allow it to grow uninhibited in mushroom substrate (Largeteau *et al.*, 2000b; Savoie *et al.*, 2001a)

The activities of *T. aggressivum* in mushroom substrate are poorly understood. It produces metabolites which inhibit the growth of *A. bisporus* (Mumpuni *et al.*, 1998; Krupke *et al.*, 2003; Guthrie & Castle, 2006) and it is able to overgrow *A. bisporus* mycelium (Savoie *et al.*, 2001b) but metabolites produced by other *Trichoderma* are more toxic to *A. bisporus* and *T. aggressivum* is able to grow in mushroom substrate in the absence of *A. bisporus* (Largeteau *et al.*, 2000b). The ability to better colonise mushroom substrate is considered to be a key difference between *T. aggressivum* and other, less harmful *Trichoderma* species, but it also produces enzymes capable of degrading *A. bisporus* cell walls (Williams *et al.*, 2003a; Guthrie & Castle, 2006).

Whether *T. aggressivum* primarily reduces mushroom yields by mycoparasitism of *A. bisporus* or by competing for nutrients in the substrate is unknown, but as *Trichoderma* species are known for opportunistically antagonising and par-

asitising competitors the true relationship is likely a mixture of the two (Kredics *et al.*, 2010; Druzhinina *et al.*, 2011).

Comparative proteomics is a powerful tool used to study disease (Pasini *et al.*, 2010) and host-pathogen interactions (Reales-Calderón *et al.*, 2012) as well as symbiotic and commensal interactions between organisms (Marra *et al.*, 2006; Mathesius, 2009) and the action of antibiotics and fungicides *in vitro* (Wenzel & Bandow, 2011; Seneviratne *et al.*, 2010). In a comparative proteomic study the organism of interest is exposed to different conditions and changes in its protein expression profile are measured, commonly by 2-dimensional gel electrophoresis. Knowing what proteins are increased or decreased in expression under different conditions gives insight into the response of the organism to those conditions.

In this study *T. aggressivum* was exposed to mushroom substrate and *A. bisporus* tissue. Whole cell protein was then extracted, separated and visualised by 2-D SDS-PAGE. Individual proteins were isolated from the gels and tryptic digest of these proteins were analysed by mass spectrometry. This allows the identification of homologous proteins from other fungi from which a can be inferred without requiring sequence data from *T. aggressivum*.

In addition, using densitometric analysis it is possible to determine the relative expression level of proteins in each condition. If a protein is up-regulated or down-regulated when the fungus is grown in the presence of mushroom substrate or *A. bisporus* tissue it can be inferred that the protein in question may play a role in the survival of *T. aggressivum* in mushroom substrate and/or its capacity for reducing mushroom yields.

Better understanding of how *T. aggressivum* operates in mushroom substrate may lead to better treatments or preventative methods for green mould disease. Knowing how *T. aggressivum* resists inhibition by substrate micro-flora and *A. bisporus* may allow for the production of substrate which is selective against *T. aggressivum* growth and understanding the mechanisms by which *T. aggressivum* antagonises *A. bisporus* may aid in the breeding of strains more resistant to green mould disease.

3.2 2-D electrophoretic profile of *Trichoderma aggressivum* across a pH 4-7 range

Whole cellular protein was obtained from 5 day liquid cultures of two reference isolates of *Trichoderma aggressivum f. europaeum*, CBS 433.95 and CBS 100526 (Sections 2.1.5, 2.3.1). Iso-electric focusing was performed across a pH range of 4-7, proteins were separated by mass using 2-D SDS-PAGE (12.5 % gel) and visualised with colloidal coomassie staining (Section 2.3.4). Figure 3.1 and Figure 3.2 show the electrophoretic profile of strain CBS 433.95 and CBS 100526 respectively.

3.3 Identification of protein homologs in *Trichoderma aggressivum* strain CBS 433.95 by LC/MS analysis of tryptic digests

Trichoderma aggressivum strain CBS 433.95 was grown in liquid culture for 5 days and protein was extracted, focused, separated and stained as described previously (Section 2.1.5, 2.3.1, 2.3.4). Figure 3.3 shows each protein spot which was excised, digested and analysed by LC/MS (Section 2.4). Spots were selected for analysis based on good separation, definition and intensity.

Table 3.1 shows results of Mascot searches using the compounds generated from the mass spectra of each protein (Section 2.4), searches were performed against all genera of fungi in the NCBIInr database.

Table 3.2 shows the Uniprot accession number (www.uniprot.org/uniprot) for each homologous protein as well as the Mascot score, coverage, pI (pI^{hom}) and molecular weight. Mascot scores greater than 57 indicate significant homology. The pI of the *T. aggressivum* proteins (pI^{nat}) can be estimated from the gel and are also included for reference.

Of the 41 spots which were processed 37 returned positive hits from the database searches of which 32 have known or inferred functions. The largest portion of the matches were proteins from *Trichoderma* species (8/38 results) with the rest being from various different fungi, *Fusarium solani* being the most commonly occurring (5/38 matches).

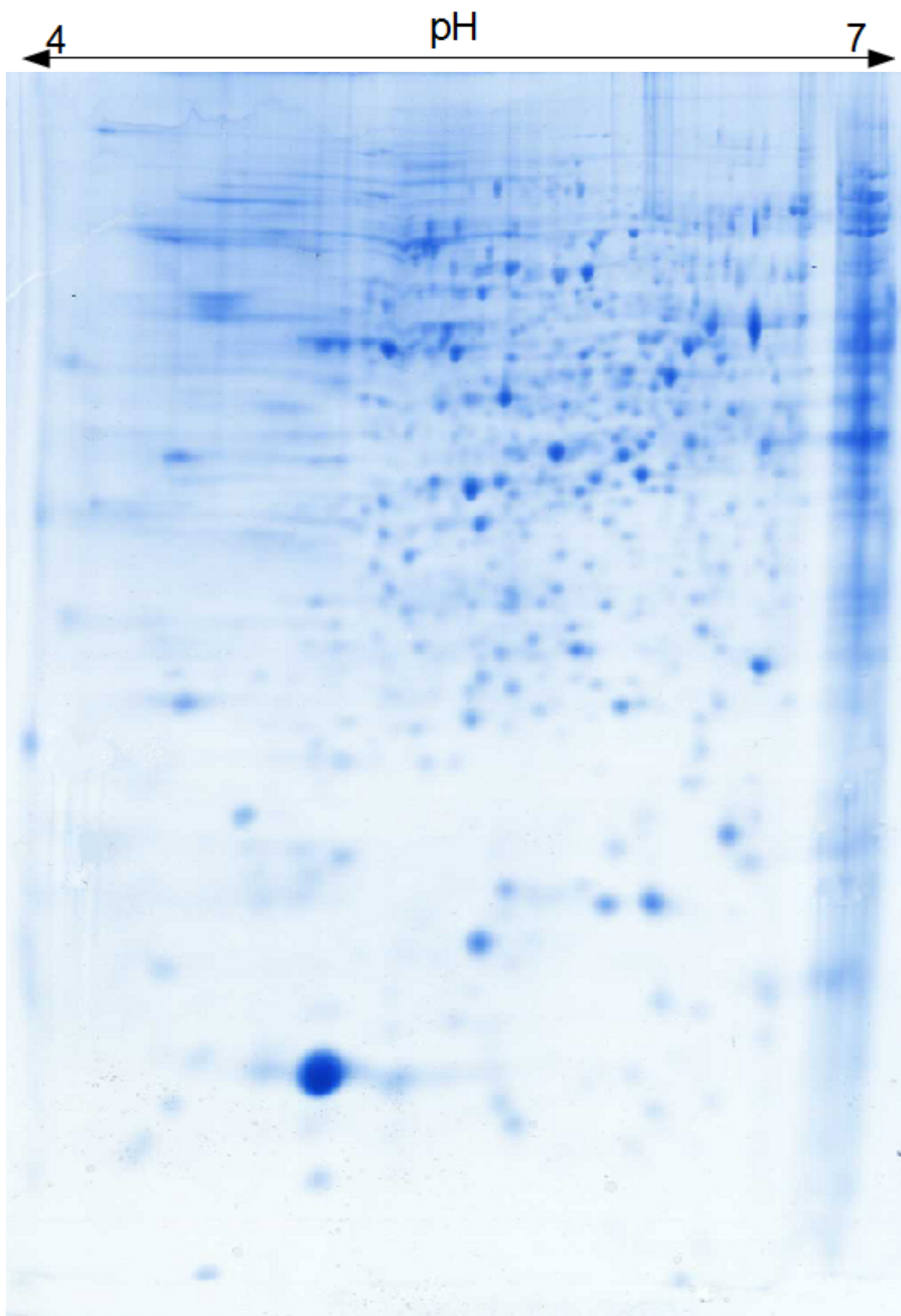

Fig. 3.1: 2-D electrophoretic profile of *Trichoderma aggressivum* strain CBS 433.95.

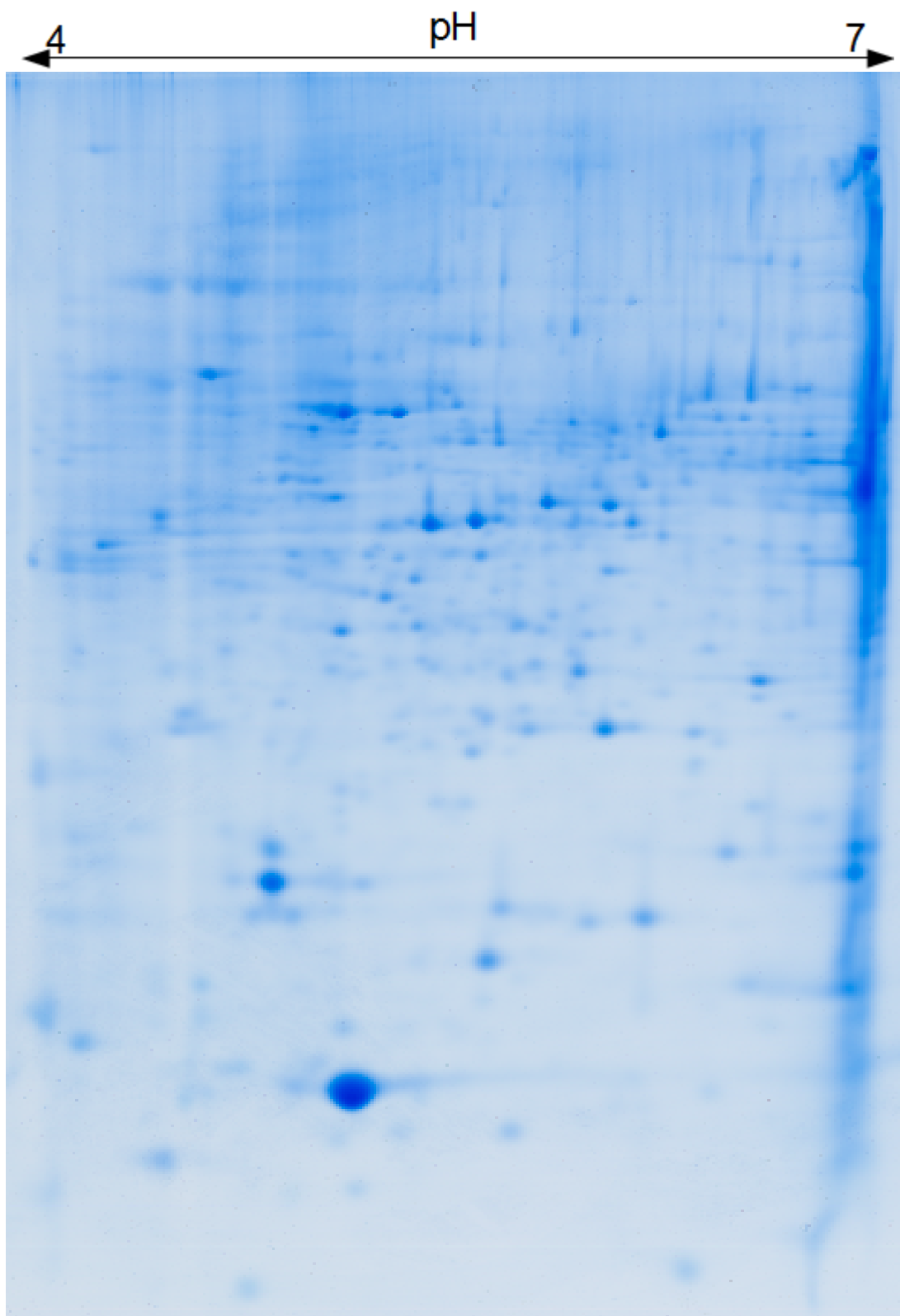

Fig. 3.2: 2-D electrophoretic profile of *Trichoderma aggressivum* strain CBS 100526.

Mascot scores ranged from 58-876 and % coverage ranged from 2-71%. The best matches in terms of Mascot score were for ATP dependent RNA helicase eIF4A from *Botryotinia fuckeliana*, Hsp70-like protein from *Glomerella graminicola* and 14-3-3 like protein from *Metarhizium anisopliae* (Mascot scores 876, 720 and 621, respectively). Three out of four of the highest coverage matches returned were proteins from *Trichoderma harzianum*; protein Hex 1 returned 2 hits with coverages of 52 and 50 % while Copper-Zinc Superoxide dismutase matched to spot 40 with 71% coverage.

The inferred function of the analysed proteins based on the known functions of their homologs covers a broad range of cellular activities. They can be broken down into 7 areas: cell metabolism (8/32), protein processing (7/32), translation (4/32), homeostasis (2/32), oxidation-reduction (2/32), stress response (2/32) and other (7/32).

The pI of the matched proteins were generally close to that measured from the gel for high Mascot score and/or % coverage matches. Matches with low Mascot scores and coverages, on the other hand, diverged widely from their expected pI, including 4 which fell outside of the isoelectric range used (spots 13, 19, 31, 38). Since these analyses were performed using tryptic digests rather than whole proteins it is possible to match one or more small sequences from a larger protein which may have different characteristics from the one which was digested. While it is possible that homologous proteins from 2 different species can have somewhat different pI and retain the same function if the differences occur outside the active site, it seems unlikely that a protein with a pI outside the 4-7 range could be a true homolog of those analysed in this study.

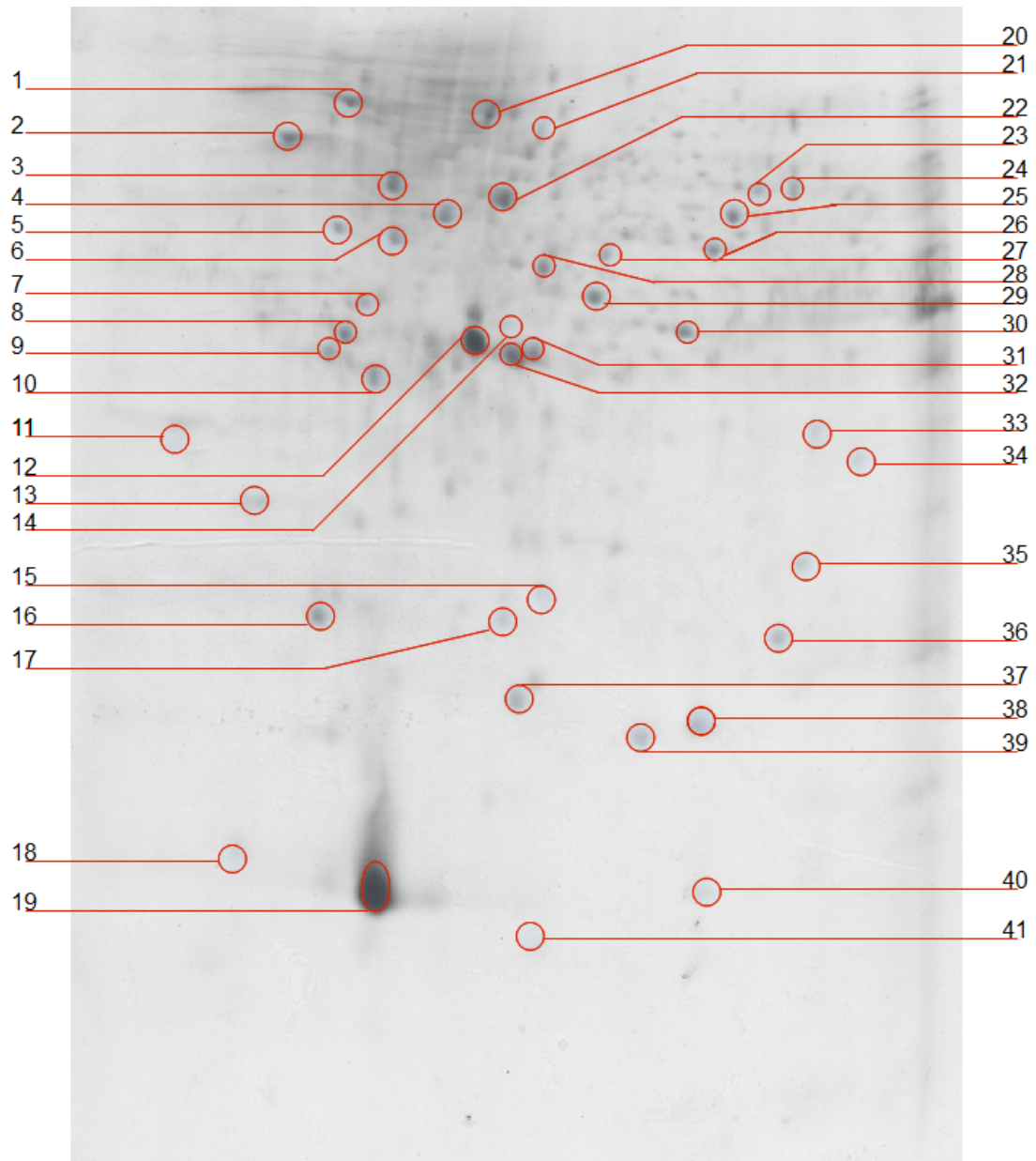

Fig. 3.3: Protein spots analysed by LC/MS from *Trichoderma aggressivum* strain CBS 433.95.

Tab. 3.1: Proteins displaying homology with LC/MS analysed *T. aggressivum* strain CBS 433.95 proteins.

Spot	Homolog name	Source	Function
1	Hsp70-like protein	<i>Glomerella graminicola</i>	Hsp70 like protein
2	Protein disulfide isomerase	<i>Trichoderma reesei</i>	Redox homeostasis
3	None found	-	Unknown
4	Enolase	<i>Botryotinia fuckeliana</i>	Glycolysis
5	ATP synthase subunit beta	<i>Aspergillus nidulans</i>	ATP synthesis
6	ATP-dependent RNA helicase eIF4A	<i>Botryotinia fuckeliana</i>	Translation initiation factor
7	40S ribosomal protein S0	<i>Podospora anserina</i>	40S ribosomal subunit
8	14-3-3-like protein	<i>Trichoderma reesei</i>	Protein secretion
9	TH14-3-3	<i>Metarhizium anisopliae</i>	Protein secretion
10	Serine/threonine-protein phosphatase PP1	<i>Neurospora crassa</i>	Protein dephosphorylation
11	Similar to beta subunit of TEF EF1B	<i>Podospora anserina</i>	Elongation factor
12	Predicted protein	<i>Candida tropicalis</i>	Unknown
13	Putative uncharacterized protein	<i>Aspergillus fumigatus</i>	Unknown
14	Transaldolase	<i>Fusarium solani</i>	Carbohydrate degradation
15	GTP-binding protein ypt3	<i>Verticillium albo-atrum</i>	Protein binding
16	Putative uncharacterized protein	<i>Sclerotinia sclerotiorum</i>	Unknown
17	YALI0B07007p	<i>Candida lipolytica</i>	Oxidoreductase regulator
18	Subtilisin-like proteinase Spm1	<i>Magnaporthe oryzae</i>	Proteolysis

Tab. 3.1: Continued

Spot	Homolog name	Source	Function
19	Jen2	<i>Kluyveromyces lactis</i>	Transmembrane transport
20	None found	-	-
21	Predicted protein	<i>Fusarium solani</i>	Carboxy-lyase
22	Rab GDP-dissociation inhibitor	<i>Neurospora crassa</i>	Protein transport
23	Predicted protein	<i>Fusarium solani</i>	Oxidoreductase
24	ATP synthase subunit beta	<i>Aspergillus nidulans</i>	ATP synthase
25	6-phosphogluconate dehydrogenase, decarboxylating	<i>Fusarium solani</i>	Carbohydrate degradation
26	Phosphoglycerate kinase	<i>Trichoderma viride</i>	Carbohydrate degradation
27	Pc21g18680 protein	<i>Penicillium notatum</i>	Unknown
28	SWIRM domain-containing protein	<i>Glomerella graminicola</i>	DNA binding
29	Actin	<i>Arthroderma gypseum</i>	Actin
30	GSTUM_00001447001	<i>Tuber melanosporum</i>	Glycolysis
31	Putative acetohydroxy-acid isomerase	<i>Gibberellium fujikuroi</i>	Amino-acid synthesis
32	Epl1 protein	<i>Trichoderma viride</i>	Plant immunostimulant
33	None found	-	Unknown
34	L-xylose reductase	<i>Trichoderma reesei</i>	Xylose/ arabinose metabolism
35	Predicted protein	<i>Fusarium solani</i>	Redox homeostasis
36	Hex 1	<i>Trichoderma harzianum</i>	Elongation factor

Tab. 3.1: Continued

Spot	Homolog name	Source	Function
37	Putative uncharacterized protein	<i>Verticillium albo-atrum</i>	Unknown
38	Hex 1	<i>Trichoderma harzianum</i>	Elongation factor
39	Superoxide dismutase [Cu-Zn]	<i>Trichoderma harzianum</i>	Superoxide dismutase (Cu-Zn)
40	Epl1 protein	<i>Trichoderma viride</i>	Plant immunostimulant
41	None found	-	Unknown

Tab. 3.2: Accession number, Mascot score and additional information for proteins analysed from *Trichoderma aggressivum* strain CBS 433.95.

Spot	Accession	Mascot score	Coverage	MW (kDa)	pI ^{hom}	pI ^{nat}
1	E3QX97	740	23%	72.671	4.95	4.82
2	O74568	239	12%	54.669	4.83	4.65
3	None found	-	-	-	-	5.00
4	A6RIS9	338	12%	47.168	5.26	5.20
5	Q5BAW5	143	6%	54.852	5.17	4.80
6	A6RJ45	876	53%	44.875	5.13	5.00
7	B2B1Z3	183	22%	31.439	4.81	5.00
8	Q9HEM9	449	37%	3.0432	4.89	4.95
9	Q27JQ9	621	47%	29.865	4.85	4.80
10	Q9UW86	72	5%	35.568	5.29	5.00
11	Q875E8	89	4%	26.102	4.37	4.20
12	C5M3J4	61	2%	69.790	4.7	5.35
13	Q4WC61	59	13%	9.288	9.97	4.65
14	C7YMG7	202	12%	35.468	5.04	5.50
15	C9SGP9	306	30%	23.251	5.46	5.60
16	A7ECN3	164	25%	18.621	4.84	4.80
17	Q6CFH1	67	12%	21.818	5.94	5.55
18	P58371	67	2%	57.170	6.44	4.55
19	Q6RFG1	82	2%	59.997	8.89	5.45
20	None found	-	-	-	-	5.45
21	C7YP39	185	9%	63.140	5.01	5.55
22	Q7S909	446	24%	51.403	5.31	5.40
23	C7YI26	391	16%	53.799	5.55	6.25
24	Q5BAW5	65	3%	54.852	5.17	6.40
25	C7YKL6	573	21%	57.753	5.99	6.20
26	P24590	210	12%	44.381	6.16	6.15
27	B6HI68	95	8%	45.645	5.55	5.80
28	E3Q9L4	58	3%	75.456	4.85	5.60

Tab.: 3.2: Continued

Spot	Accession	Mascot score	Coverage	MW (kDa)	pI ^{hom}	pI ^{nat}
29	E4UZI4	383	26%	41.661	5.45	5.80
30	D5G5R4	283	14%	46.827	5.97	5.75
31	C1L3C1	277	15%	44.883	8.21	5.50
32	A0PCX8	71	12%	14.356	6.23	6.55
33	None found	-	-	-	-	6.55
34	Q8NK50	157	20%	28.478	5.76	6.40
35	C7ZD60	103	8%	25.220	5.87	5.55
36	E0YRV9	429	52%	24.334	6.75	5.30
37	C9SFN3	65	11%	16.214	9.24	4.90
38	E0YRV9	475	50%	24.334	6.75	5.20
39	A8BA83	321	71%	15.767	5.58	5.60
40	A0PCX8	81	12%	14.356	6.23	5.80
41	None found	-	-	-	-	5.00

3.4 Identification of protein homologs in *Trichoderma aggressivum* strain CBS 100526 by LC/MS analysis of tryptic digests

Two dimensional SDS-PAGE followed by LC/MS analysis of protein spots was performed for *Trichoderma aggressivum* strain CBS 100526 as described previously (Section 2.1.5, 2.3.1, 2.3.4, 2.4).

Figure 3.4 shows the 49 individual protein were excised for LC/MS analysis (Section 2.4). Spot selection criteria were the same as in Section 3.3. Table 3.3 shows results of Mascot searches using the compounds generated from the mass spectra of each protein (Section 2.4.3). Table 3.4 shows the accession number for each homologous protein as well as the Mascot score, coverage, pI (pI^{hom}) and molecular weight (MW) of the homologous proteins and the estimated pI (pI^{nat}) of the *T.aggressivum* protein measured from the gel.

Of the 49 spots analysed in this section 44 returned matches from the NCBI nr database, 33 of those were matched with significant homology (Mascot score >57)

and of those 31 have known or inferred functions. The majority of matches are from the *Trichoderma virens* and *Trichoderma reesie* genome databases (18 and 4 matches, respectively), many of these spots returned multiple matches to the same protein in different *Trichoderma* species, the match with the highest Mascot score is shown. These proteins are putative, based on presumed coding regions in the genome, and as such are not assigned names (the names listed in Table 3.3 are the names of the open reading frames) but functions have been proposed for most based on sequence similarity with genes of known function. The remaining matches came from *Trichoderma harzianum* (3), *Candida spp.* (3) and others (6).

Mascot scores ranged from 36-943 and % coverage ranged from <1-75%. The highest matching Mascot scores were TRIVIDRAFT_74949 (Mascot score 943 & 913), Actin (Mascot score 676) and TRIVIDRAFT_71413 (Mascot score 636). In terms of % coverage the best matches were Superoxide dismutase, HEX_1 and TRIVIDRAFT_74949 with coverages of 75%, 57% and 48%, respectively.

The functions assigned to the analysed proteins can be grouped into oxidoreductases (8/31), protein transport and synthesis (5/31), glycolytic enzymes (4/31), cytoskeletal proteins (3/31), degradative enzymes (3/31) and other (8/31).

The relation between the pI of homologous proteins and that expected value is not as clear for these data as for strain CBS 433.95. There is a large difference between the theoretical pI of the homologs (based on sequence) and that of the native proteins estimated from their position on the gel in many cases, even for high confidence matches. This may be as a result of differences in the proteins outside of the matching region or due to the subjective nature of the estimation of native pI.

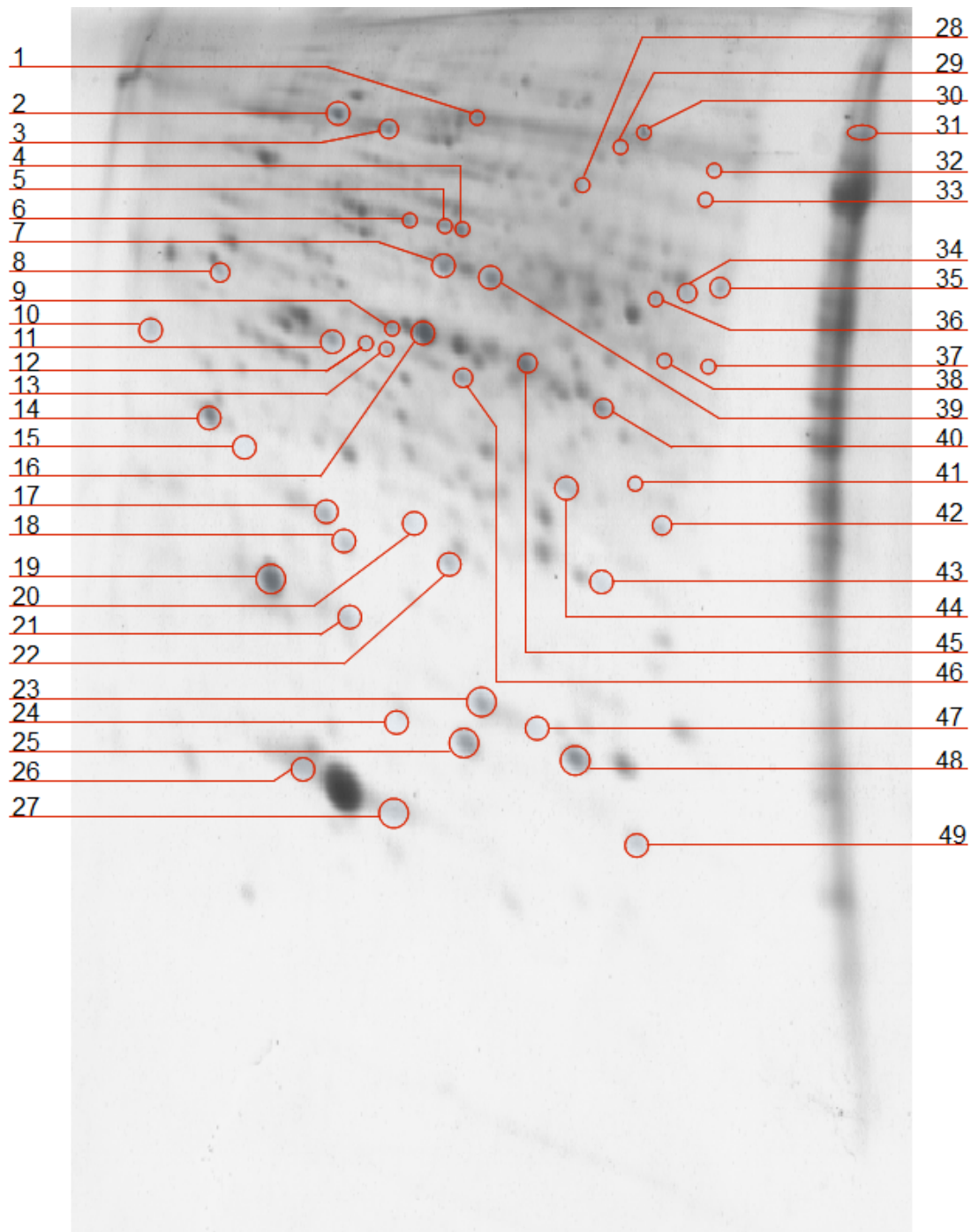

Fig. 3.4: Protein spots analysed by LC/MS from *Trichoderma aggressivum* strain CBS 100526.

Tab. 3.3: Proteins displaying homology with LC/MS analysed *Trichoderma aggressivum* strain CBS 100526 proteins.

Spot	Homolog name	Source	Function
1	Chromodomain helicase hrp3	<i>Schizosaccharomyces pombe</i>	Chromatin remodeling
2	TRIVIDRAFT_74949	<i>Trichoderma virens</i>	Aldehyde dehydrogenase
3	Lysophospholipase NTE1	<i>Scheffersomyces stipitidis</i>	Lipid homeostasis
4	TRIVIDRAFT_71413	<i>Trichoderma virens</i>	Protein transport
5	TRIVIDRAFT_71413	<i>Trichoderma virens</i>	Protein transport
6	Aldehyde dehydrogenase	<i>Metarhizium acridum</i>	Oxidoreductase
7	Actin	<i>Cleistogenes songorica</i>	Cytoskeleton
8	TRIVIDRAFT_216692	<i>Trichoderma virens</i>	Protein biosynthesis
9	Predicted protein	<i>Trichoderma reesei</i>	Acyltransferase
10	None found	-	-
11	None found	-	-
12	Pyruvate dehydrogenase e1 subunit	<i>Grosmannia clavigera</i>	Pyruvate dehydrogenation
13	TRIVIDRAFT_230681	<i>Trichoderma virens</i>	Unknown
14	None found	-	-
15	Hsp90 co-chaperone AHA1	<i>Saccharomyces cerevisiae</i>	Stress response
16	TRIVIDRAFT_74949	<i>Trichoderma virens</i>	Aldehyde dehydrogenase
17	None found	-	-
18	CAGL0H03311g	<i>Candida glabrata</i>	Unknown

Tab.: 3.3: Continued

Spot	Homolog name	Source	Function
19	ATP-dependent RNA helicase DED1	<i>Candida albicans</i>	RNA translation
20	Proteasome subunit alpha type	<i>Trichoderma virens</i>	Protein catabolism
21	TRIVIDRAFT_71356	<i>Trichoderma virens</i>	Oxidoreductase
22	Putative uncharacterized protein	<i>Trichoderma virens</i>	Unknown
23	Probable zinc metalloprotease	<i>Clavispora lusitanae</i>	Proteolysis
24	Hex 1	<i>Trichoderma harzianum</i>	Elongation factor
25	TRIEDRAFT_73967	<i>Trichoderma reesei</i>	Actin binding
26	None found	-	-
27	Chromodomain helicase hrp3	<i>Schizosaccharomyces pombe</i>	Chromatin remodeling
28	TRIVIDRAFT_88883	<i>Trichoderma virens</i>	Choline dehydrogenase
29	Sorting nexin MVP1	<i>Candida glabrata</i>	Vacuolar protein transport
30	TRIVIDRAFT_169516	<i>Trichoderma virens</i>	Lipid degradation
31	Hex 1	<i>Trichoderma harzianum</i>	Elongation factor
32	TRIVIDRAFT_87974	<i>Trichoderma virens</i>	Transketolase
33	Dehydratase	<i>Trichoderma reesei</i>	Di-hydroxy dehydratase
34	TRIVIDRAFT_186586	<i>Trichoderma virens</i>	Pentose-phosphate shunt
35	TRIVIDRAFT_74949	<i>Trichoderma virens</i>	Aldehyde dehydrogenase
36	TRIVIDRAFT_74949	<i>Trichoderma virens</i>	Aldehyde dehydrogenase

Tab.: 3.3: Continued

Spot	Homolog name	Source	Function
37	Norsolorinic acid reductase	<i>Trichoderma atroviride</i>	Oxidoreductase
38	TRIVIDRAFT_53536	<i>Trichoderma virens</i>	Endonuclease
39	TRIVIDRAFT_74949	<i>Trichoderma virens</i>	Aldehyde dehydrogenase
40	Actin	<i>Cleistogenes songorica</i>	Cytoskeleton
41	Glyceraldehyde-3-phosphate dehydrogenase	<i>Erysiphe graminis</i>	Glycolysis
42	TRIVIDRAFT_33817	<i>Trichoderma virens</i>	Glycolysis
43	None found	-	
44	Secretory lipase, putative	<i>Neosartorya fischeri</i>	Lipid degradation
45	None found	-	-
46	None found	-	-
47	TRIEDRAFT_55552	<i>Trichoderma reesei</i>	Unknown
48	Superoxide dismutase [Cu-Zn]	<i>Trichoderma harzianum</i>	Superoxide degradation
49	None found	-	-

Tab. 3.4: Accession number, Mascot score and additional information for proteins analysed from *Trichoderma aggressivum* strain CBS 100526.

Spot	Accession number	Mascot score	% Coverage	MW (kDa)	pI ^{hom}	pI ^{nat}
1	O14139	46	0	159744	6.32	5.00
2	G9NAQ0	122	12	54165	5.88	5.00
3	A3LYZ4	31	1	172492	8.86	5.15
4	G9MTN9	561	37	51591	5.33	5.50
5	G9MTN9	636	41	51591	5.33	5.45
6	E9DS21	97	7	54461	6.06	5.15
7	D6C5B7	586	39	41827	5.45	5.45
8	G9N455	216	28	24963	4.33	4.50
9	G0RNE6	357	29	41183	5.86	5.10
10	None found	-	-	-	-	4.40
11	None found	-	-	-	-	5.00
12	F0XBV7	178	9	42053	6.97	5.00
13	G9MRQ8	518	29	41416	5.95	5.10
14	None found	-	-	-	-	4.50
15	Q12449	44	5	39585	7.03	4.60
16	G9NAQ0	206	10	54165	5.88	4.25
17	None found	-	-	-	-	5.00
18	Q6FS57	61	3	27258	9.98	5.00
19	P06634	32	0	73026	8.41	4.75
20	G9N428	415	41	30119	5.43	4.75
21	G9MQT2	114	18	17852	5.16	5.00
22	G9N2A8	151	18	21480	5.35	5.40
23	C4Y9H0	27	0	114603	6.43	5.50
24	E0YRV9	623	57	24334	6.75	5.25
25	G0R881	132	17	17414	5.66	5.50
26	None found	-	-	-	-	4.80
27	O14139	48	0	159744	6.32	5.25
28	G9N370	598	22	65088	5.4	5.80

Tab.: 3.4: Continued

Spot	Accession number	Mascot score	% Coverage	MW (kDa)	pI ^{hom}	pI ^{nat}
29	Q6FNH2	48	3	59242	5.8	6.00
30	A3LYZ4	71	2	81530	5.73	6.10
31	E0YRV9	293	38	24334	6.75	7.00
32	G9N9F6	72	3	75548	5.84	6.45
33	G0RFA6	352	19	65175	6.04	6.40
34	G9MVH9	370	16	54459	5.72	6.30
35	G9NAQ0	913	38	54165	5.88	6.45
36	G9NAQ0	378	23	54165	5.88	6.25
37	G9NMQ9	154	7	42580	6.15	6.40
38	G9MU97	98	3	28630	5.12	6.25
39	G9NAQ0	943	48	54165	5.88	5.55
40	D6C5B7	676	46	41827	5.45	6.00
41	Q00640	115	6	36751	6.02	6.10
42	G9MEX6	99	2	39234	5.51	6.20
43	None found	-	-	-	-	6.00
44	A1D8L8	60	4	47956	5.44	5.80
45	None found	-	-	-	-	5.75
46	None found	-	-	-	-	5.50
47	G0RAL0	219	39	16717	5.80	5.75
48	A8BA83	478	75	15874	5.58	5.80
49	None found	-	-	-	-	6.15

3.5 2-D electrophoretic analysis of *Trichoderma aggressivum* strain CBS 100526 grown in the presence of mushroom substrate and mushroom tissue.

Malt extract broth, malt extract broth with Bulk Phase III mushroom substrate and malt extract broth with *Agaricus bisporus* tissue were inoculated with *Trichoderma aggressivum* strain CBS 100526 in duplicate (Section 2.1.6). Cellular protein was extracted from *T. aggressivum* mycelium as per Section 2.3.1 and pooled between the replicates in each treatment. Strain 100526 was selected for this analysis as it gave more significant response to both treatments than strain 433.95 during preliminary analysis.

Protein was separated in 2 dimensions and visualised as per Section 2.3.4. For each treatment 2-D PAGE was performed in triplicate. Figure 3.5 shows one gel from each treatment.

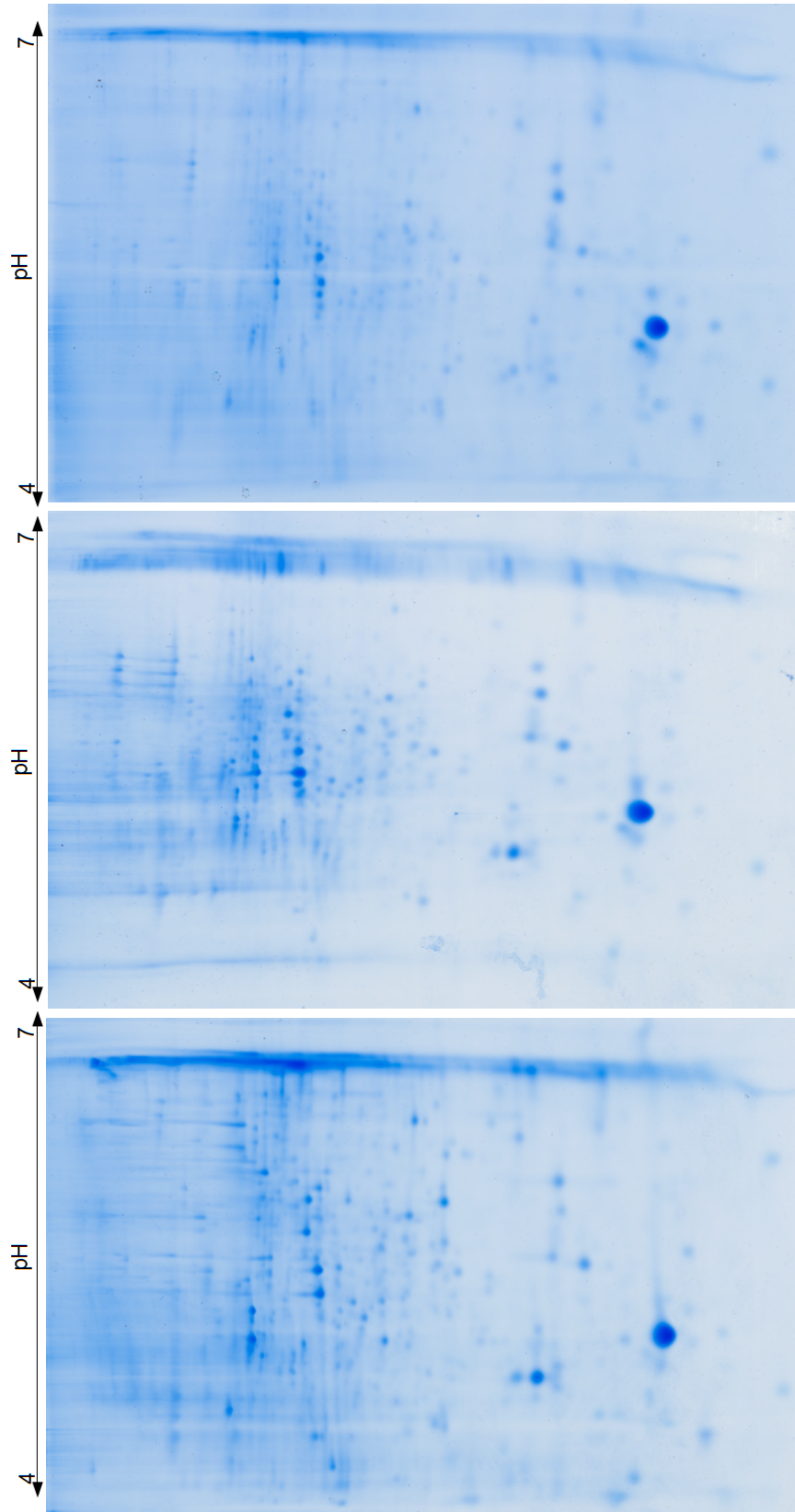

Fig. 3.5: 2-Dimensional protein profile of *Trichoderma aggressivum* strain CBS 100526 grown in different media.
A - 1 % malt extract broth, B - 1 % malt extract broth, 1% Bulk Phase III mushroom substrate, C - 1 % (w/v) malt extract 1 % mushroom cap tissue.

3.6 Differential protein expression in *Trichoderma aggressivum* strain CBS 100526 grown in the presence of Bulk Phase III mushroom substrate and mushroom tissue.

Stained proteins spot pattern and density was analysed using Progenesis SameSpots software (section 2.3.5). Each gel was aligned to a reference gel so that the spots could be matched between treatments and normalised. Relative expression level was calculated automatically.

Statistically significant differential expression was observed for 23 protein spots of which 19 were analysed by LC/MS. Differential spots which were analysed by LC/MS (section 2.4) are shown in Figure 3.6. The relative expression levels for each treatment are shown in Table 3.5 and Figure 3.7.

Mascot searches were performed using the NCBIInr and SwissProt databases returning 14 matches of which 7 displayed significant homology, no matches were obtained for spots 8-13. Table 3.6 shows the matches found for each spot, significant homology is indicated by Mascot scores in excess of 57 and 42 for the NCBIInr and SwissProt databases, respectively.

Spot 1 was upregulated slightly in the presence of *Agaricus bisporus* tissue and downregulated in the presence of mushroom substrate. This spot was matched with a probable Xaa-Pro aminopeptidase from *Unicocarpus reesei*, albeit with low confidence. Xaa-Pro amino peptidases are Manganese dependent proteases which cleave any peptide on the N-terminal side of proline residues.

Spot 2 was down-regulated in the presence of mushroom substrate and was matched with oligosaccharyl transferase subunit stt3 from *Schizosaccharomyces pombe* although the Mascot score was too low to ensure significant homology. This is a transmembrane protein which is thought to catalyse the site specific N-glycosylation of proteins in the endoplasmic reticulum. Glycosylation is an important post-translational modification which can significantly alter protein function and localisation.

Spot 3 was upregulated in the presence of both mushroom tissue and substrate. Three results were obtained from the analysis of this spot, all displaying significant homology. The first hit is an un-named protein from *Trichoderma viride* which displays sequence motifs which suggest an RNA binding function.

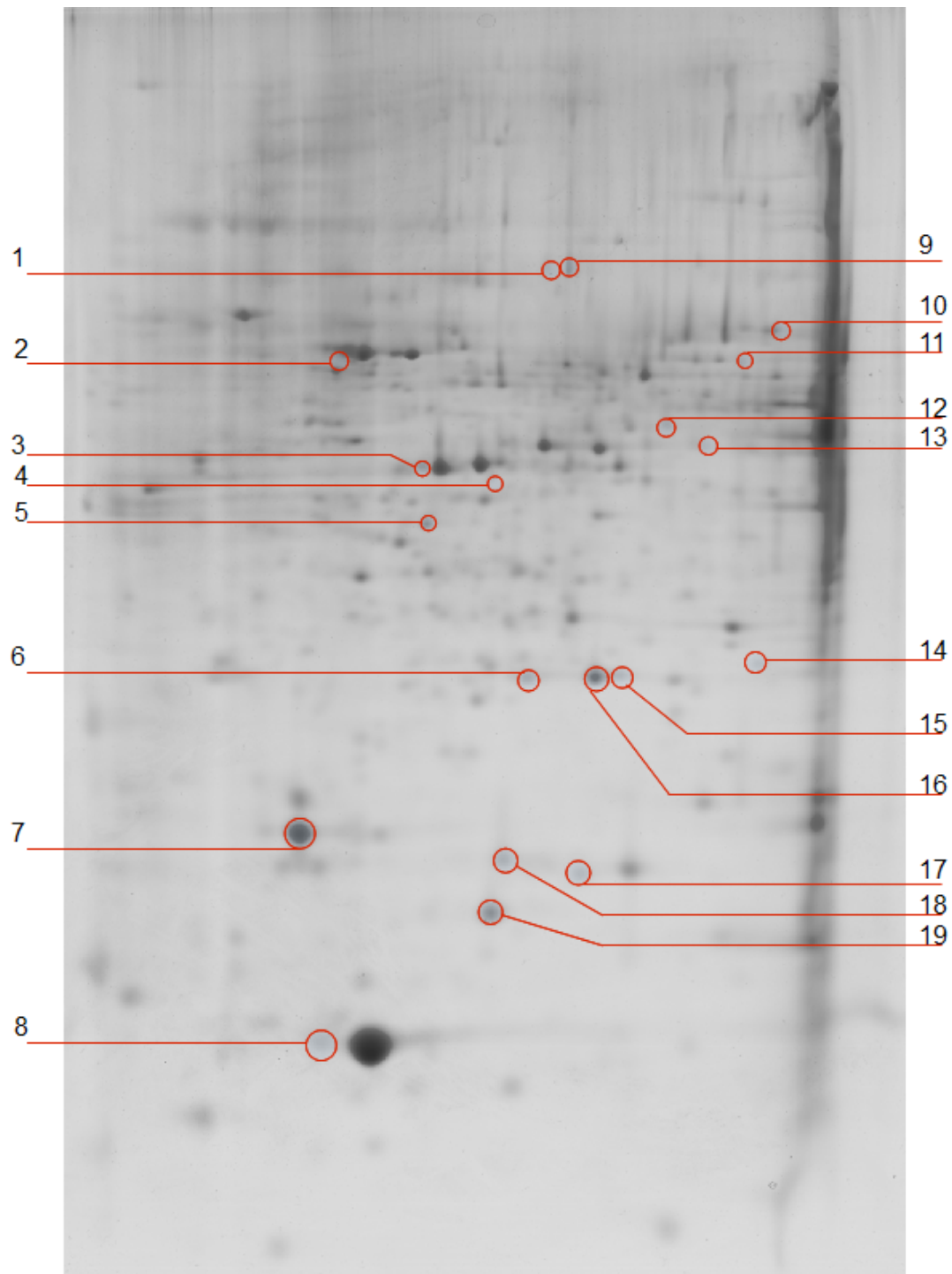

Fig. 3.6: Differentially expressed protein in *Trichoderma aggressivum* strain CBS 100526 with exposure to *Agaricus bisporus* tissue and/or Bulk Phase III mushroom substrate.

The second and third hits were for a 60S acidic ribosomal protein from *Trichoderma reesei* and *Neurospora crassa*, respectively. Both of these proteins are constituents of the ribosome and may be analogs of the *T. viride* protein.

Spot 4 was upregulated in the presence of mushroom substrate. The highest ranking hit for this spot (and the only one with a characterised function) was iron-manganese superoxide dismutase from *T. viride*. Superoxide dismutase detoxifies superoxide free radical, producing hydrogen peroxide in the process. It is an important part of the cell's ability to resist harm by oxidative stress.

Spot 5 was down-regulated in both treatments relative to the control. Analysis of this protein yielded 4 Mascot results of which the three significant matches were proteins in the spermidine/spermine synthase family. Spermidine is a growth factor for many micro-organisms and may play a role in macromolecular stabilisation and cellular longevity in eukaryotes.

Spot 6 was downregulated in both treatments and displayed homology with maintenance of telomere capping protein 2 from *Zygosaccharomyces rouxii*. Telomeres are repetitive DNA sequences at the ends of chromosomes which protect them from degradation and improve the fidelity of chromosome duplication. Telomere shortening also plays a role in cell senescence, so effective telomere capping may promote cell longevity.

Spot 7 was upregulated slightly (1.25 fold) in the *A. bisporus* tissue treatment and downregulated in the Phase III substrate treatment. This spot was matched to orotidine 5' phosphate decarboxylase from *Paracoccoides brasiliensis* but not with significant homology. Orotidine 5' phosphate decarboxylase is involved in the biosynthesis of pyrimidines, including 3 which are components of RNA and/or DNA. It is worth noting that this was also analysed in Section 3.4 (spot label 19) without any significant matches, in spite of it being a relatively abundant protein in both cases. It is also not immediately apparent in the 2-D electrophoretic profile of *T. aggressivum* strain CBS 433.95 3.1.

Spots 8-13 were downregulated in both treatments but returned no matches after LC/MS and Mascot analysis. Whether this is a result of the low relative abundance of the proteins or because of poor matching in the databases searched is unknown. Spot 8 was also analysed in Section 3.4 (spot label 26) and returned no significant hits in either case.

Tab. 3.5: Normalised expression levels and relative fold changes of spots differentially expressed in *Trichoderma aggressivum* strain CBS 100526 in response to *Agaricus bisporus* tissue or Bulk Phase III mushroom substrate.

Spot	Expression level			Fold change		P value
	Control	Tissue	Compost	Tissue	Compost	
1	8.05E+6	8.72E+6	4.85E+6	+1.08	-1.66	5.0E-2
2	1.12E+8	1.20E+8	5.76E+7	+1.07	-1.95	3.4E-2
3	3.50E+7	6.69E+7	6.18E+7	+1.91	+1.76	5.0E-3
4	6.81E+6	7.82E+6	1.97E+7	+1.15	+2.89	1.0E-3
5	7.70E+6	5.86E+6	4.87E+6	-1.31	-1.58	3.4E-2
6	4.26E+7	2.21E+7	2.33E+7	-1.93	-1.82	3.2E-2
7	1.47E+8	1.84E+8	5.59E+7	+1.25	-2.62	5.5E-5
8	1.48E+8	2.02E+8	3.51E+8	+1.36	+2.37	7.0E-3
9	1.77E+7	1.68E+7	8.08E+6	-1.06	-2.19	3.2E-2
10	2.41E+7	1.55E+7	8.67E+6	-1.55	-2.78	3.4E-2
11	9.46E+6	5.38E+6	5.10E+6	-1.76	-1.85	3.1E-2
12	4.29E+6	2.63E+6	2.13E+6	-1.63	-2.01	7.0E-3
13	5.06E+6	2.41E+6	3.51E+6	-2.10	-1.44	4.0E-3
14	4.66E+6	1.00E+7	2.29E+6	+2.15	-2.03	2.0E-3
15	1.66E+7	7.44E+6	9.29E+6	-2.23	-1.78	4.0E-3
16	9.62E+7	2.68E+7	1.47E+7	-3.59	-6.54	1.7E-4
17	4.78E+7	9.24E+7	1.45E+8	+1.93	+3.04	4.9E-4
18	1.69E+7	2.17E+7	4.44E+7	+1.28	+2.63	3.8E-4
19	1.39E+7	2.26E+7	3.18E+7	+1.62	+2.29	4.0E-3

Spot 14 displayed 2-fold upregulation in the *A. bisporus* tissue treatment and 2-fold down regulation in the substrate treatment. The best matching protein for this spot was guanylate kinase from *Grosmannia clavigera*. This protein may be involved in purine biosynthesis and the production of nucleic acids.

Spot 15 was down regulated in both treatments. The spot was matched to a putative cytochrome DASH, but not with significant homology. This protein is a light induced enzyme that repairs DNA strand breaks which are caused by exposure to UV radiation.

Spot 16 was the most strongly downregulated protein observed in the experiment. It was downregulated 3.6 fold in the *A. bisporus* tissue treatment and 6.5 in the mushroom substrate treatment. This protein displayed homology with NAD-specific glutamate dehydrogenase from *Saccharomyces cerevisiae*, although the score was just below the significance threshold. This protein produces ammonia from glutamate and is involved in the metabolism of various nitrogen containing compounds.

Spots 17-19 did not return any significant hits in this study, but they can be shown to be the same as spots 48, 23 and 25 respectively from Figure 3.4 by gel alignment.

Spot 17 was upregulated 1.9 and 3.0 fold in the *A. bisporus* tissue and mushroom substrate treatments, respectively. When analysed in section 3.4 this spot showed extensive homology with copper-zinc superoxide dismutase. This protein detoxifies superoxides in the same manner as iron-manganese superoxide dismutase, but has a different cellular location and metal co-factor.

Spot 18 was upregulated in both treatments and was matched with a probable zinc metalloprotease in *Clavispora lusitaniae*, but without significant homology. This protein is a glycosylated transmembrane peptidase. It does not induce site-specific cleavage but instead is involved in general proteolysis.

Spot 19 was upregulated in both treatments. It was matched to a putative protein from *Trichoderma reesei* of unknown function.

Tab. 3.6: Mascot search results for analysed peptides from differentially expressed *Trichoderma aggressivum* strain CBS 100526 proteins.

Spot	Homolog name	Species	Accession	Score	Database
1	Probable Xaa-Pro aminopeptidase	<i>Uncinocarpus reesei</i>	C4JY72	34	Swissprot
2	Oligosaccharyl transferase subunit stt3	<i>Schizosaccharomyces pombe</i>	O94335	28	Swissprot
3	TRIVIDRAFT_92231	<i>Trichoderma viride</i>	G9ND76	242	NCBIInr
	60S acidic ribosomal protein P0	<i>Trichoderma reesei</i>	G0RFG1	200	NCBIInr
	60S acidic ribosomal protein	<i>Neurospora crassa</i>	Q96TJ5	64	Swissprot
4	Superoxide dismutase [Fe-Mn]	<i>Trichoderma viride</i>	G9N1G1	146	NCBIInr
	TRIATDRAFT_82820	<i>Trichoderma atroviride</i>	G9NIJ0	102	NCBIInr
	MYCGRDRAFT_103841	<i>Mycosphaerella graminicola</i>	F9X7C5	66	NCBIInr
	Uncharacterized protein yae1	<i>Aspergillus terreus</i>	Q0CX45	38	Swissprot
5	TRIVIDRAFT_187417	<i>Trichoderma virens</i>	G9N9E1	157	NCBIInr
	TPHA_0A01420	<i>Tetrapisispora phaffii</i>	G8BMU7	74	NCBIInr
	Spermidine synthase	<i>Neurospora crassa</i>	Q9Y8H7	74	Swissprot
	Ketol-acid reductoisomerase	<i>Neurospora crassa</i>	P38674	35	Swissprot
6	Maintenance of telomere capping protein 2	<i>Zygosaccharomyces rouzii</i>	C5E1C0	64	NCBIInr
	Maintenance of telomere capping protein 2	<i>Zygosaccharomyces rouzii</i>	C5E1C0	38	Swissprot
7	Orotidine 5'-phosphate decarboxylase	<i>Paracoccidioides brasiliensis</i>	Q9C131	31	Swissprot
8-13	None found	-	-	-	-
14	Guanylate kinase	<i>Grosmannia clavigera</i>	F0X7L2	80	NCBIInr

Tab.: 3.6: Continued

Spot	Homolog name	Species	Accession	Score	Database
14	AOL_s00076g67	<i>Arthrobotryx oligospora</i>	G1X8W0	68	NCBIInr
	NECHADRAFT_69701	<i>Nectria haematococca</i>	C7YSP1	66	NCBIInr
15	Putative cryptochrome DASH	<i>Gibberella zeae</i>	Q4I1Q6	31	Swissprot
16	NAD-specific glutamate dehydrogenase	<i>Saccharomyces cerevisiae</i>	P33327	41	Swissprot
17	Superoxide dismutase [Cu-Zn]	<i>Trichoderma harzianum</i>	A8BA83	478	NCBIInr
	Superoxide dismutase [Cu-Zn]	<i>Neurospora crassa</i>	P07509	88	Swissprot
18	Probable zinc metalloprotease	<i>Clavispora lusitanae</i>	C4Y9H0	27	Swissprot
19	TRIREDRAFT_73967	<i>Trichoderma reesei</i>	G0R881	132	NCBIInr

3.7 Discussion

3.7.1 Protein homologies

Trichoderma aggressivum is unique among *Trichoderma* species in the damage it causes in the mushroom industry. It is also a recently characterised species and there is still much to be learned about its ecology, genetics and propagation.

Two dimensional SDS-PAGE coupled with LC/MS is a powerful tool for the isolation and identification of proteins. In the absence of a genome sequence for *T. aggressivum* comparative proteomics can provide unique insights into the biology of the fungus by identifying protein homologs in other fungi and thereby assigning functions to the *T. aggressivum* proteins.

In this study 75 protein homologs were identified for *Trichoderma aggressivum* proteins with functions having been assigned to 69 of them. These homologs were drawn from a wide range of species, the recently annotated *Trichoderma reesei*, *Trichoderma harzianum* and *Trichoderma atroviride* genome databases provided the majority of homologs with many others coming from yeasts, probably because the proteomes of those organisms are well studied and there are several complete genome sequences for them. Protein functions can be broadly described as metabolic, informational, structural and other.

Metabolic proteins are involved in the uptake of nutrition and production of energy. Unsurprisingly for such a fast growing fungus, metabolic proteins account for a large proportion of the identified proteins from *T. aggressivum*. Thirty of the identified proteins had functions such as carbohydrate degradation, the glycolytic pathway, ATP synthesis and protein degradation. Some of the more interesting functions were those involved in the metabolism of xylose and arabinose (Spot 34, Tab 3.1) as these sugars are present in the hemicellulose component of mushroom substrate and the pentose phosphate shunt, which is an alternative to the glycolytic pathway where pyruvate is converted into a 5-carbon sugar so that it can be processed similarly to xylose and arabinose. None of the identified proteins showed any evidence of being involved in the degradation of fungal cell wall components, which would be a good indicator of the mycoparasitic potential of the fungus (Williams *et al.*, 2003a; Guthrie & Castle, 2006). However, these types of enzymes are generally secreted from the cell so that is not to

Fig. 3.7: Relative expression levels of differentially expressed proteins in *Trichoderma aggressivum* strain CBS 100526 when exposed to *Agaricus bisporus* tissue and Bulk Phase III mushroom substrate.

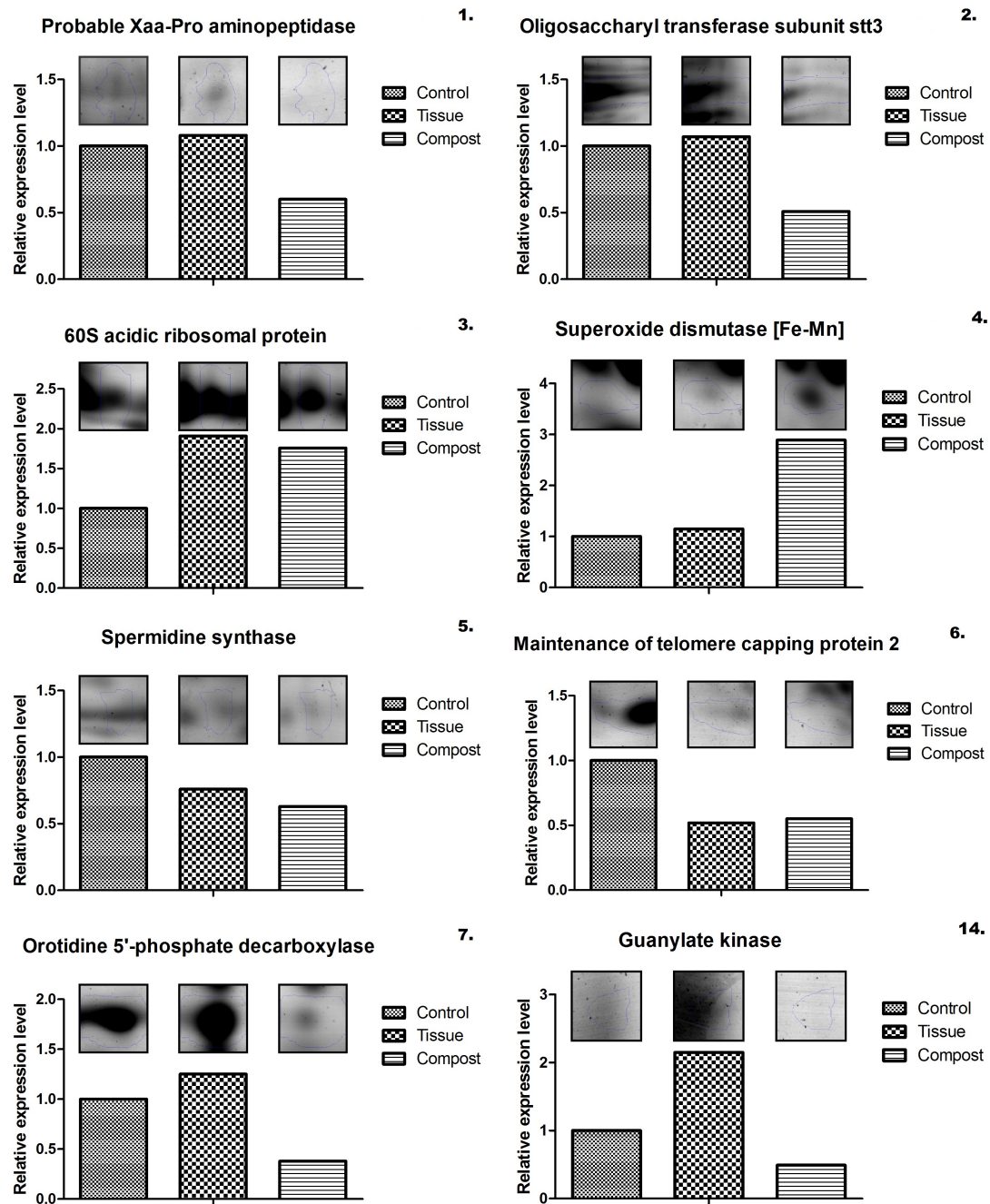
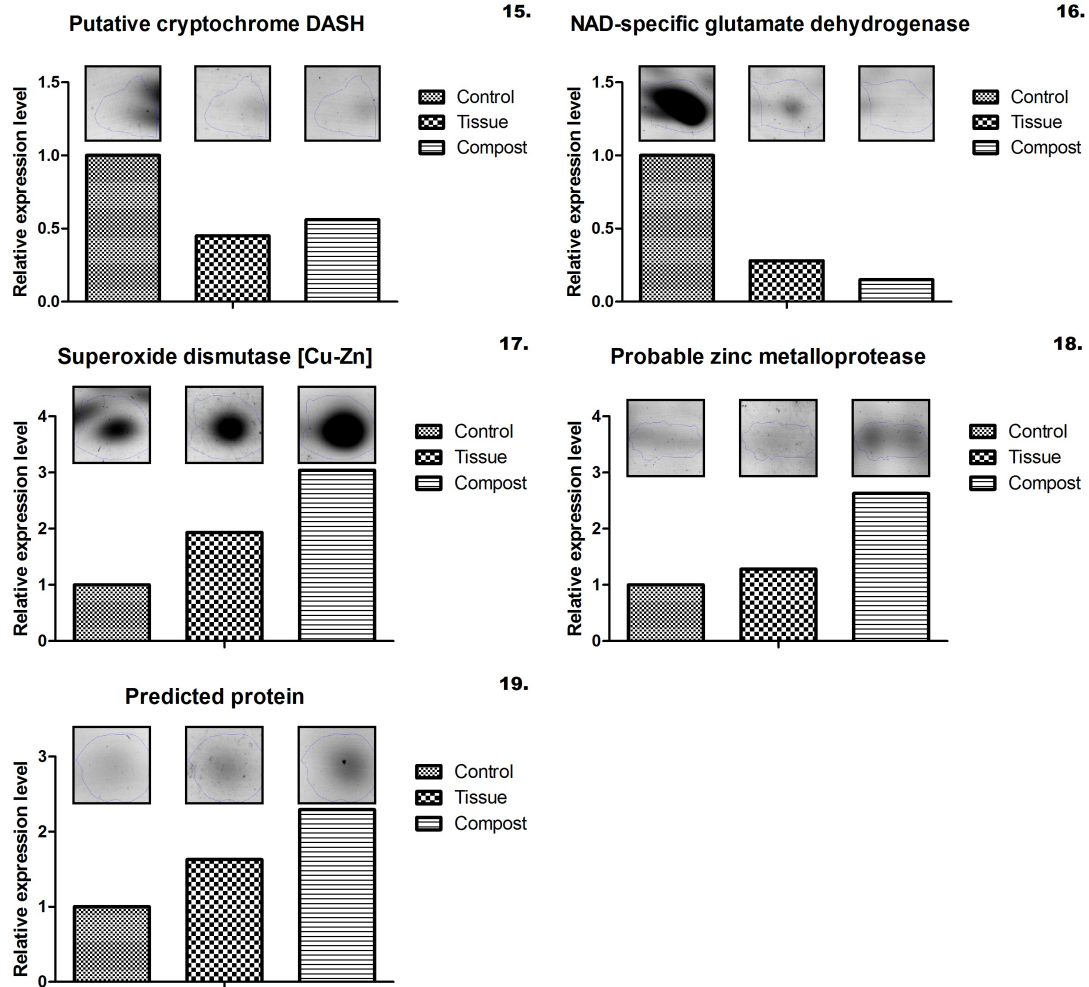

Fig 3.7: Continued



say that they were not being produced during the experiments. Further studies involving the secreted protein fraction obtained from the culture supernatant might yield more information on the production of chitinase and other cell wall degrading enzymes by *T. aggressivum*.

Informational proteins are those that are involved in DNA duplication, transcription and translation. These proteins are generally more conserved between organisms than proteins involved in metabolism as their purpose is largely independent of the ecological niche of the organism. Ten of the analysed proteins have functions in this category, including transcription factors, ribosome component proteins and other proteins which interact with nucleic acids. Without knowing the exact nature of these proteins, whether they are linked to specific genes or cell division it is difficult to assess their significance. The only elongation factor with known function identified was Hex 1, which has homologs in all *Trichoderma* species. Hex 1 is a major component of the woronin body complex as well as a transcription factor. Woronin bodies are present at the periphery of fungal hyphae where they prevent cellular leakage by blocking septal pores when hyphae are sheared (Lew, 2011). Hex1 has been implicated in the response of *T. atroviride* to plant pathogenic fungi (Marra *et al.*, 2006). This protein was identified 4 times in this study, possibly because it accounts for a large proportion of total protein in the cell envelope of *Trichoderma spp.* and because it forms complexes which may be visualised at different positions in a 2 dimensional gel (Curach *et al.*, 2004).

Structural proteins are core components of the cell which allow it to maintain integrity and segregate other molecules into cellular partitions. Ten of the analysed proteins had structural or homeostatic roles including cytoskeletal components such as actin and actin binding proteins, transmembrane transporter proteins and redox enzymes. Cytoskeletal proteins have an important role in the physical shape of the cell. Actin is often constitutively expressed by cells as it forms the cellular “backbone”, it can also be mobilised to cause the cell to grow or move in a specific direction (chemokinesis) and so can be important in saprotropism. The maintenance of homeostasis is important for any organism, particularly those in harsh environments. Transmembrane proteins allow communication between the intracellular and extracellular environment. Two classes

of transmembrane proteins were observed in this study, 14-3-3 like proteins and membrane transport channels. 14-3-3 like proteins are a large class of proteins conserved in all Eukarya, they have a variety of functions but are predominantly involved in the induction of signals across cell membranes. This signal transduction allows cells to adapt to their external environment and allows intercellular communication. Membrane transport channels are involved in the movement of molecules across membranes, they may be involved in the uptake of nutrient from the environment, the secretion of molecules such as digestive enzymes into the environment and the movement of molecules between internal cell compartments, such as in the Golgi apparatus (Klemsdal *et al.*, 1996).

Other proteins did not fall into any of the above 3 categories. Epl1 protein is a protein first isolated from *Trichoderma atroviride* which has been described as the most commonly secreted protein in that species (Seidl *et al.*, 2006). Epl1 belongs to a class of proteins which elicit an immune response in plants, but it has been described as an important aspect of the biocontrol faculty of *Trichoderma* spp. which are used for controlling plant pathogenic fungi.

Superoxide dismutase and Hsp70/90 like proteins are proteins involved in cellular stress response, the former is discussed in Section 3.7.2. Hsps, or heat shock proteins are stress inducible chaperone proteins. They are induced in response to a variety of stresses, not just heat, which are characterised by changes in free energy levels within the cell. Hsps ensure correct folding of proteins so that non-functional proteins are not produced, which would result in cellular damage.

The last subset of proteins identified are those with unknown functions. Some of these proteins are putative, based on open reading frames which do not have a function assigned to them as yet, others returned Mascot scores below the significance threshold. If there was no match found for a protein there are two possible explanations. The initial concentration may have been below the limit of detection of the mass spectrometer used, this is likely the case for many of the unknown proteins which are either faint or very small spots on the gel. There were a number of proteins for which no database match was found which were clearly in high abundance, however, and it is possible that these are novel *T. aggressivum* proteins for which no homolog exists in the databases. In the future it would be ideal to re-analyse these spots using *de novo* sequencing to determine the amino

acid sequence of the protein and possibly assign functions to them. Novel proteins would give particular insight into the specific adaptations for *T. aggressivum* as they are not present in other *Trichoderma* which have been sequenced. Unique *T. aggressivum* proteins could also be useful diagnostic markers for species/strain differentiation and may also be virulence markers.

3.7.2 Differentially expressed proteins and the virulence of *Trichoderma aggressivum*

Densitometric analysis also allows the relative expression levels of each protein to be compared under different conditions. By challenging *Trichoderma aggressivum* with different environments it is possible to measure the up, or down-regulation of proteins in response to the environment.

In this study homologs for 7 proteins which changed in expression in the presence of mushroom substrate or *Agaricus bisporus* tissue were identified with high confidence by LC/MS. A further 5 returned database hits, but the quality of the sequence match (based on Mascot score) was not statistically significant.

Proteins which were upregulated in the presence of *A. bisporus* tissue included a 60S acidic ribosomal protein P0, guanylate kinase, copper zinc superoxide dismutase and a protein of unknown function. Each of these proteins was also up-regulated in the presence of Phase III mushroom substrate apart from guanylate kinase, which was down-regulated. In the Phase III substrate treatment iron manganese superoxide dismutase was also up-regulated.

60S acidic ribosomal protein P0 is a protein conserved in all eukaryotes which is the ortholog of the *Escherichia coli* protein L10 (Rich & Steitz, 1987). This protein has a specific conserved protein binding C-terminus which allows it to form a complex with 2 other proteins and an RNA binding N-terminus region which attaches the complex to the ribosomal RNA where it is involved in protein elongation (Hagiya *et al.*, 2005); similar proteins are virulence factors in the human parasite *Plasmodium* (Arevalo-Pinzon *et al.*, 2010), they are expressed on the organism's cell surface and interfere with the host immune response. The human P0 protein has been implicated as a target for the autoimmune condition lupus erythematosus (Frampton *et al.*, 2000). Different forms of this protein can confer resistance to the sordarin class of fungicides (Santos & Ballesta, 2002;

Santos *et al.*, 2004). As a component of the ribosome 60S ribosomal protein P0 can affect the translation of other proteins and has been linked with the cellular response to stress and toxins (Abramczyk *et al.*, 2003; Maniratanachote *et al.*, 2006). P0 is a phosphoprotein, with several phosphorylation sites, protein kinase 60S is one of the enzymes that phosphorylates P0 in *Saccharomyces cerevisiae*. This protein is inactivated by superoxide dismutase (Abramczyk *et al.*, 2003), the resultant dephosphorylation of P0 may play a role in changing protein expression under oxidative stress conditions.

Superoxide dismutase is an important part of the oxidative stress response and is vital to growth in aerobic environments (Peskin, 1997). All aerobic organisms produce superoxide radicals during respiration, so production of these enzymes is vital to minimise damage due to oxidative stress from within the cell and from the external environment (Bai *et al.*, 2001). Superoxide dismutase is also involved in other stress responses such as temperature dependant stress and certain toxins (Giles *et al.*, 2005; Hwang *et al.*, 2003).

Superoxide is commonly produced by organisms as a non-specific anti-microbial agent. Mammalian and insect immune cells produce superoxide, among other reactive oxygen species, to destroy internalised or adjacent pathogens (Condliffe *et al.*, 1998; Bergin *et al.*, 2005; Muñoz, 2007). In the yeasts *Candida albicans* and *Cryptococcus neoformans* production of superoxide dismutase is a virulence factor, because it allows them resist attack by host immune cells (Hwang *et al.*, 2002; Cox *et al.*, 2003).

The immune response of plants involves the accumulation and release of superoxide radicals in oxidative bursts (Lamb & Dixon, 1997). In *Phytophthora* and *Botrytis* it has been shown that challenging a host plant with a non pathogenic fungal strain results in an initial oxidative burst, followed later by a more intense production of reactive oxygen species and other antimicrobials which prevents the fungus from colonising the host plant (Perrone *et al.*, 2003; Unger *et al.*, 2005). Pathogenic varieties of these fungi prevent the occurrence of this secondary oxidative burst. In *Phytophthora* this evasion of the immune response can be directly attributed to the enzymatic removal of superoxide (Able *et al.*, 1998) and in *Botrytis* a higher concentration of hydrogen peroxide associated with virulent strains points to a possible similar mode of action.

Many fungi produce exogenous superoxide using cell wall bound NADPH oxidases as a deterrent to competing microbes in co-culture (Silar, 2005). Production of superoxide is thought to be part of the response of *A. bisporus* to stress (Largeteau *et al.*, 2010). Plant matter decomposing basidiomycetes like *Agaricus* also produce superoxide to degrade lignin (Hammel *et al.*, 2002; Tornberg & Olsson, 2002; Guillén *et al.*, 1997) and there is a link between the production of laccase and other polyphenol oxidases which depolymerise lignin and superoxide production (Muñoz *et al.*, 1997). Laccase production is promoted in *A. bisporus* confronted with antagonists (Flores *et al.*, 2009; Savoie & Mata, 1998) and pathogens (Largeteau *et al.*, 2000b). Enhanced secretion of extracellular laccase is associated the formation of brown-rings of depolymerised phenolic compound at the border between competing fungi and a cessation of growth (Tsujiyama & Minami, 2005). In co-cultures between *A. bisporus* and *T. aggressivum* brown line formation occurs but the growth of *T. aggressivum* is not inhibited and it proceeds to overgrow the mycelium of susceptible *A. bisporus* varieties (Savoie *et al.*, 2001b). It is possible that the ability of *T. aggressivum* to overgrow brown-rings produced by *A. bisporus* may be as a result of tolerance to oxidative stress provided by the induction of superoxide dismutase and other stress tolerance proteins.

There is also a correlation between the ability of a *T. aggressivum* strain to colonise unpasteurised mushroom substrate and its ability to overgrow brown-lines produced by *A. bisporus* (Savoie *et al.*, 2001b). The microbial flora of mushroom substrate is one of the factors which is thought to ensure that it is selective for the growth of *A. bisporus* and inhibit the growth of non-aggressive *Trichoderma* species (Savoie *et al.*, 2001a). The upregulation of the two identified superoxide dismutase proteins suggest that *T. aggressivum* was also under oxidative stress in the mushroom substrate treatment, so the oxidative stress response of *T. aggressivum* may have a dual role in its ability of to resist growth inhibition by substrate micro-flora and by *A. bisporus*.

Guanylate kinases are enzymes which catalyse the phosphorylation of guanosine monophosphate to guanosine diphosphate using ATP as the donor molecule requiring magnesium ions as a metal co-factor (Berger *et al.*, 1989; Blaszczyk *et al.*, 2001). They are essential to the production of deoxyguanosine triphos-

phate, the monomeric form of the purine base guanine. Loss of function of the gene coding for this protein is lethal in *Saccharomyces cerevisiae* (Konrad, 1992). Guanosine diphosphate is also one of the intermediaries in the cyclic guanosine monophosphate pathway. Cyclic GMP is a key signalling molecule in a variety of organisms and in fungi is known to be involved in such processes as conidiation (Li *et al.*, 2010), cell division (Eckstein, 1988) and hyphal extension and branching (Robson *et al.*, 1991). Whether it is producing guanosine di-phosphate for the synthesis of DNA or signalling molecules guanylate kinase is likely associated with cell growth. This protein was upregulated in *T. aggressivum* in the presence of *A. bisporus* tissue and down regulated in the presence of mushroom substrate. Other researchers have found that the presence of *A. bisporus* enhances the growth of *T. aggressivum* (Mumpuni *et al.*, 1998; Largeteau *et al.*, 2010), and *T. aggressivum* suffers some degree of growth inhibition in mushroom substrate (Largeteau *et al.*, 2000b), which may be related to this differential expression of guanylate kinase.

Proteins homologous with spermidine synthase and maintenance of telomere capping protein 2 (MTC2) were downregulated in the presence of mushroom substrate and mushroom tissue, with spermidine synthase being more strongly reduced in expression in the substrate treatment. Spermidine synthase is an aminopropyltransferase which catalyses the production of the polyamine spermidine from putrescine (Pegg, 1986). Spermidine is the precursor of spermine and hypusine, an essential amino acid in eukaryotes (Chattopadhyay *et al.*, 2003). Spermidine is involved in many other biological processes, such as the response to thermal and oxidative stresses (Kuznetsov *et al.*, 2006; Tkachenko & Fedotova, 2007) and specific toxins (Qin & Lan, 2004) and pathogens (Fu *et al.*, 2011). The number of pathways and regulatory mechanisms involving spermidine, as well as the sometimes contrary effects of polyamines in these processes makes it difficult to suggest an explanation for the reduction of the expression of spermidine synthase in both the *A. bisporus* tissue and Bulk Phase III compost treatment, or the possible outcome of such downregulation. Perhaps the most reasonable explanation is based on experiments with spermidine-synthase-deficient *S. cerevisiae*, in which the addition of exogenous spermidine induced a reduction in the expression of several oxidative stress response genes, including glutathione per-

oxidase and cytosolic catalase (Chattopadhyay *et al.*, 2009). Both these enzymes protect the cell from peroxide induced damage. With an increase in the levels of superoxide dismutase in the cell there would be an increase in cellular hydrogen peroxide which may be removed by proteins induced by a reduction in spermidine concentration.

Maintenance of telomere capping protein 2 (MTCP2) belongs to a class of proteins which have been shown to exacerbate telomere-shortening-induced cell cycle arrests in *S. cerevisiae* (Addinall *et al.*, 2008) which were previously uncharacterised open reading frames. Without knowing the mechanism by which these proteins improve the viability of telomere deficient mutant yeast it is difficult to suggest what role MTCP2 might serve in *T. aggressivum*. Many telomere associated proteins are also involved in DNA repair outside of telomeres and might be expected to be upregulated in an oxidative stress response but MTCP2 has no assigned catalytic function or DNA binding domains so is unlikely to be directly responsible for the ligation of double stranded DNA breaks. Further study of this protein in *T. aggressivum* might reveal that it has a different function than in *S. cerevisiae*.

The overall impression given by the identified differentially expressed proteins is of *T. aggressivum* reacting with an oxidative stress response to *A. bisporus* tissue and, more strongly, to mushroom substrate. There is an alteration in gene expression, as evidenced by an increase in ribosomal protein production and there are changes to metabolic pathways involved in the biosynthesis of spermidine and guanine, both of which are important signalling molecules and growth factors. These changes in protein expression may be due to components of the *Agaricus* tissue and mushroom substrate which cause oxidative damage to the *T. aggressivum* cell, or which induce changes in the metabolism of *T. aggressivum* leading to increased production of reactive oxygen species. This oxidative stress response may be part of the reason for the enhanced aggressiveness of *T. aggressivum*, its ability to grow uninhibited in mushroom substrate and to out-compete and displace *A. bisporus*, ultimately resulting in reduced mushroom yields.

4. *TRICHODERMA AGGRESSIVUM* IN BULK PHASE III MUSHROOM SUBSTRATE

4.1 Introduction

4.1.1 Epidemiology of *Trichoderma aggressivum* in Bulk Phase III mushroom substrate

In the Bulk Phase III systems pasteurised Phase II substrate is mixed with *Agaricus bisporus* spawn and incubated in large tunnels under stringent environmental controls to ensure that it is thoroughly colonised by *A. bisporus* mycelium and free from unwanted micro-organisms; this incubation period is called spawn-run. These systems are generally considered less susceptible to *Trichoderma aggressivum* infection than *in situ* spawn run systems because of the more advanced exclusionary measures, stricter hygiene and greater level of automation involved and because substrate fully colonised by *A. bisporus* has been shown relatively resistant to infection by *T. aggressivum* (Fletcher, 1997; Rinker & Alm, 2000).

With the increase in the popularity of the Bulk Phase III system there was an observed decrease in the incidences of *T. aggressivum* infection in Europe. However, *T. aggressivum* infections have appeared in Bulk Phase III produced substrate subsequently (Lemmers, 2010).

Research into *T. aggressivum* infection of fully spawn-run substrate was carried out on *in situ* spawn run substrate, which is different from Bulk Phase III substrate in that it is not bulk handled after spawn-run is complete. In the Bulk Phase III system the substrate is bulk handled at the end of spawn-run when the Phase III tunnel is emptied, the substrate is filled into trucks, transported to the grower and filled into shelves. This raises the question of whether fully spawn run substrate retains its resistance to *T. aggressivum* when bulk handled.

A further question is whether the addition of nutritional supplements to Bulk

Phase III substrate after spawn run can promote the growth of *T. aggressivum*. The high level of susceptibility of substrate to infection at spawning gas has been linked to the easily available carbohydrate present in the spawn grains, which may provide a foothold for *T. aggressivum* to grow in the relatively inhospitable environment (Seaby, 1996b). This source of carbohydrate is depleted by Phase III, which has been described as a possible reason for the relative resistance of fully spawn run substrate to *T. aggressivum* infection (Rinker, 1997). However, the addition of nutritional supplements to substrate after spawn-run has become a common method of increasing mushroom yield and quality. These supplements contain additional nutrients, including carbohydrates, which may promote the growth of *T. aggressivum*, but there is currently no information available on this subject.

This study involved 3 medium scale cropping experiments where healthy Bulk Phase III substrate was inoculated with *T. aggressivum* inoculum at the bulk handling stage. *T. aggressivum* inoculum was produced from Phase II substrate which was infected with *T. aggressivum* at spawning and then spawn-run to produce a Phase III compost with a high *T. aggressivum* load. This inoculum was then diluted into healthy Bulk Phase III substrate, cased and cropped. This mimics a Bulk Phase III process in which a localised infection occurs during spawn-run and is diluted into the whole mass of substrate during bulk handling. In the first two experiments replicate plots were prepared using substrate supplemented with Nutrigain (a commercially available mushroom supplement) and unsupplemented substrate to assess whether the addition of a nutritional supplement after spawn-run has an effect on *T. aggressivum* infection.

4.1.2 *Methods for the detection of Trichoderma aggressivum* in mushroom substrate

It is desirable to be able to quantify the level of *Trichoderma aggressivum* in mushroom substrate for monitoring purposes and in order to assess factors which may improve or impede the growth of the fungus.

Microbiological methods for enumeration of *T. aggressivum* propagules are relatively simple and inexpensive but can be time consuming and do not allow an immediate species identification (Hagn *et al.*, 2007). Molecular methods have

the ability to selectively detect and identify *T. aggressivum* in a one step process but they are technically more complex and considerably more expensive than microbiological methods.

In this study *T. aggressivum* infected Phase III substrate was screened using microbiological and molecular detection methods. The objective was to assess the relative efficacy of these methods in terms of precision, accuracy, sensitivity, speed and ease of use. These attributes are important for the detection of *T. aggressivum* on both an experimental and industrial scale.

4.1.3 Aim of the study

- To assess the potential for *Trichoderma aggressivum* infected mushroom substrate to infect Bulk Phase III substrate.
- To assess the effect of bulk handling on the impact of *T. aggressivum* infection in Bulk Phase III mushroom substrate.
- To determine the effect of adding substrate supplements during bulk handling on *T. aggressivum* in Bulk Phase III mushroom substrate.
- To assess the efficacy of molecular and microbiological detection methods for the detection and enumeration of *T. aggressivum* propagules in Bulk Phase III mushroom substrate.

4.2 Experimental

4.2.1 Fungal strains

In each cropping experiment the *Agaricus bisporus* strain used was Sylvan A15 and the *Trichoderma aggressivum* isolate used was FM10.

4.2.2 Preparation of inoculum

Phase II mushroom substrate was inoculated with *Trichoderma aggressivum* spores on spawn grains at spawning. Six grains were coated with $\sim 10^6$ *T. aggressivum* spores per grain and added to 18 kg Phase II mushroom substrate. The substrate was covered and incubated under standard spawn-run conditions to produce Phase III substrate which was heavily colonised by *T. aggressivum* (Figure 4.1 B, C and D); this infected substrate was used as inoculum in subsequent experiments. At the end of spawn-run inoculum was thoroughly mixed by hand to ensure an even distribution of *T. aggressivum* and samples were taken to quantify the initial level of *T. aggressivum* colonisation in terms of propagules per gram inoculum. Inoculum was prepared separately for each cropping experiment.

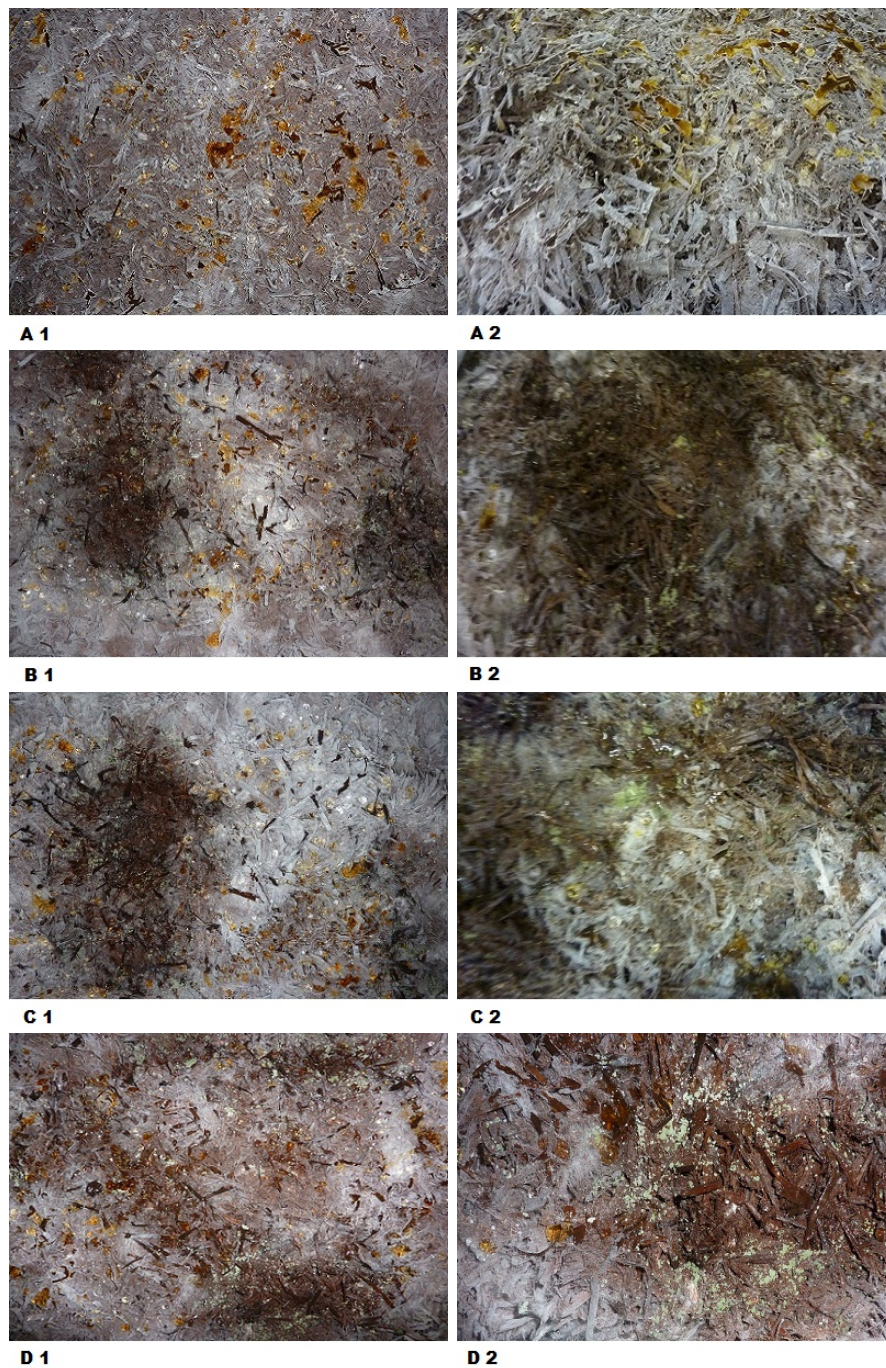

Fig. 4.1: Production of *Trichoderma aggressivum* infected Phase 3 compost. Control (A) and infected (B,C,D) compost spawn running 14 (1) and 25 (2) days post infection.

4.2.3 *Infection of Bulk Phase III substrate*

Inoculum prepared in Section 4.2.2 was added to uninfected Bulk Phase III mushroom substrate to produce 4 infection levels, 100 g/kg, 10 g/kg, 1 g/kg and 0.1 g/kg (weight inoculum/weight healthy substrate), equivalent to a dilution of 10^{-1} , 10^{-2} , 10^{-3} , 10^{-4} infected substrate by weight. A control group of uninfected Phase III substrate was also prepared.

Each experiment included 5 infection levels (including uninfected) exposed to two treatments, with each combination of infection level and treatment being replicated 4 times, for a total of 40 experimental plots per experiment (Table 4.1). Plot dimensions were 52 cm \times 40 cm \times 25cm and contained 18 kg (fresh weight) of mushroom substrate for experiments 1 and 2, and 16 kg (fresh weight) of substrate for experiment 3. Experimental plots were laid out in a random block design with a space of 1 cm (Experiment 1) or 5 cm (Experiments 2 and 3) between plots and were incubated under standard mushroom growing conditions. Mushrooms were harvested in 1-3 flushes and weighed.

Sampling of substrate for *T. aggressivum* quantification was carried out prior to plot filling during Experiments 2 and 3. For each plot the full mass of substrate was laid out on a work surface after infection and 2×100 g samples were taken by pooling multiple smaller volumes of substrate from 10 points distributed evenly across the total mass of substrate. One of the 100 g subsamples was sent to FERA (York) for qPCR analysis and the other was mixed a further time prior to analysis by WMA, MPN and DPA (Section 2.1.7).

Tab. 4.1: Generalised treatment composition for cropping experiments

Infection level	No. of plots		Total
	Treatment A	Treatment B	
Control	4	4	8
10^{-4}	4	4	8
10^{-3}	4	4	8
10^{-2}	4	4	8
10^{-1}	4	4	8
Total	20	20	40

4.2.4 Cropping experiment 1

The factors studied in this experiment were the effect of dilution of *Trichoderma aggressivum* infected Phase III substrate (inoculum) into healthy Bulk Phase III substrate and the effect of supplement of *T. aggressivum*. The two treatments in this experiment were supplemented (Phase III substrate supplemented with 0.75 % w/w Nutrigain supplement added at casing) and unsupplemented (no additional supplements added to the substrate).

The level of substrate mixing during the preparation of experimental units in this experiment was low, simulating a low level of mixing during bulk handling. Infected substrate was added to the bottom of crate in which cropping was to be performed and mixed with approximately 25 % of the total volume of substrate. The remainder of the substrate was filled into the crate on top.

The number of *T. aggressivum* propagules per gram inoculum was determined to be 2.62E+8 cfu/g by MPN analysis (Section 2.1.7).

4.2.5 Cropping experiment 2

The experimental treatments in this experiment were the same as in Section 4.2.4 but with more mixing of inoculum and substrate, simulating a higher level of mixing during bulk handling.

Prior to filling into crates the healthy Bulk Phase III substrate was weighed into polyethylene bags to which the infected substrate and supplement (Nutrigain 0.75% w/w) were added. The substrate was then emptied onto a clean plastic sheet and mixed manually before filling into crates.

The number of *T. aggressivum* propagules per gram inoculum was determined to be 1.76E+09 cfu/g by MPN analysis (Section 2.1.7).

4.2.6 Cropping experiment 3

In this experiment the factors studied were *Trichoderma aggressivum* infection level and type of mixing. The same dilution (by weight) of infected Phase III substrate into healthy substrate was performed as previously but in one half of the experimental units mixing was performed as in section 4.2.4 (light mixed treatment) while the other half was mixed as in section 4.2.5 (heavy mix treatment). No supplement was used in this experiment.

The number of *T. aggressivum* propagules per gram in the inoculum was determined to be 1.42E+08 cfu/g by MPN analysis (Section 2.1.7).

4.2.7 Quantification and detection of *Trichoderma aggressivum* infection in inoculated Bulk Phase III mushroom substrate

Samples (100 g) of Phase III mushroom substrate were taken from each treatment in cropping experiment 2 and the heavy mix treatment of cropping experiment 3 after inoculation with infected substrate. *Trichoderma aggressivum* levels in each sample were measured by most probable number analysis (MPN), weed mould analysis (WMA) and direct plating assay (DPA) (Section 2.1.7). An additional subsample (100 g) of substrate was sent to FERA UK for q-PCR analysis.

4.3 Results

4.3.1 Cropping experiment 1

Figure 4.2 shows the first flush mushroom yield from each treatment and infection level. Table 4.2 shows the results of 2 way ANOVA performed on the yield data.

Infection level had a highly significant effect on mushroom yield ($P < 0.0001$) with reductions in yield of up to 60 % at the highest level of infection. Supplementation was not shown to have a significant impact on mushroom yield ($P = 0.8533$). No significant interaction was observed between these factors ($P = 0.4874$), meaning that the addition of supplement did not tend to enhance the growth of *Trichoderma aggressivum* regardless of infection level.

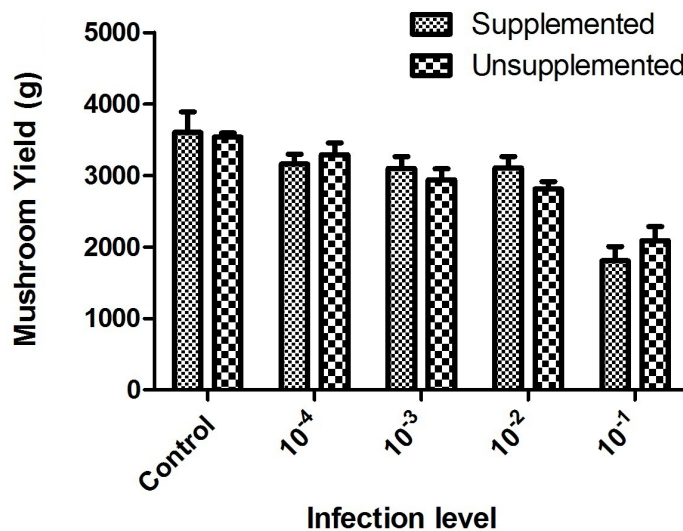

Fig. 4.2: Effect of infection level and supplement on first flush mushroom yield - experiment 1. Mean and standard error for 4 replicates.

Tab. 4.2: Two way ANOVA of mushroom yield - experiment 1.

Source of variation	% of total variation	P value	Df	F
Infection level	74.41	<0.0001	4	24.39
Supplementation	0.03	0.8533	1	0.035
Interaction	2.69	0.4874	4	0.880
Residual			30	

4.3.2 Cropping experiment 2

Figure 4.3 shows the mushroom yield from each treatment and infection level in experiment 2. In this experiment yield reductions were noticeably more severe than in experiment 1, with total crop loss occurring in the first flush for the 2 highest infection levels, but the overall trend is similar.

Infection level was the only factor to significantly affect the result ($P < 0.0001$). Supplementation did not significantly affect the mushroom yield ($P = 0.89$) and no significant interaction was observed between the factors ($P = 0.99$).

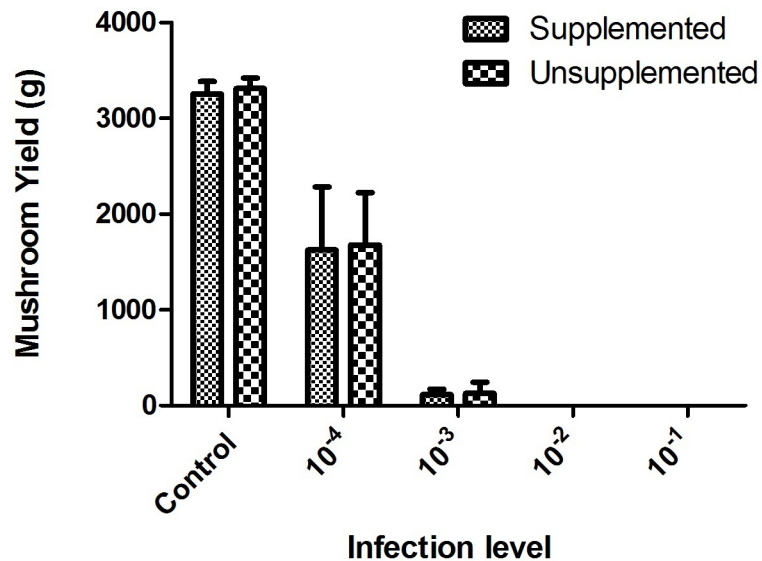

Fig. 4.3: Effect of infection rate and supplement on first flush mushroom yield - experiment 2. Mean and standard error for 4 replicates.

Tab. 4.3: Two way ANOVA of mushroom yield - experiment 2.

Source of variation	% of total variation	P value	Df	F
Infection level	87.78	<0.0001	4	53.94
Supplementation	0.01	0.8915	1	0.018
Interaction	0.01	0.9999	4	0.005
Residual			30	

4.3.3 Cropping experiment 3

The first flush mushroom yield from each treatment and infection level are given in Figure 4.4. Two way ANOVA was performed on the yield data, results are given in Table 4.4.

In this experiment both factors significantly affected the mushroom yield ($P < 0.0001$) and there was also a significant interaction between the factors ($P = 0.0090$). This indicates that the heavy mix treatment had an increasingly more severe impact on yield as the infection level increased.

Figure 4.5 is a composite image of photographs taken of each plot at the beginning of the third flush of the crop, it also illustrates that the green mould symptoms and crop reduction are exacerbated in the heavy mix treatment.

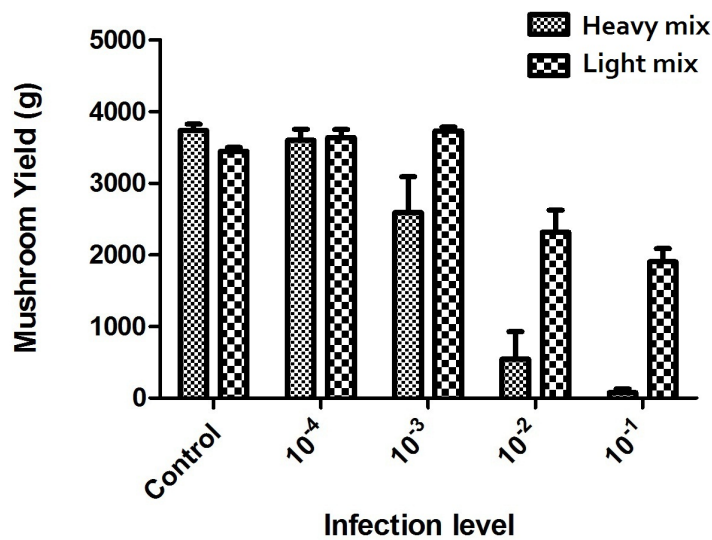

Fig. 4.4: Effect of infection level and supplement on first flush mushroom yield - experiment 3. Mean and standard error for 4 replicates.

Tab. 4.4: Two way ANOVA of mushroom yield - experiment 3.

Source of variation	% of total variation	P value	Df	F
Infection level	77.21	<0.0001	4	54.46
Mixing	8.92	<0.0001	1	34.48
Interaction	4.91	0.0090	4	8.314
Residual			30	

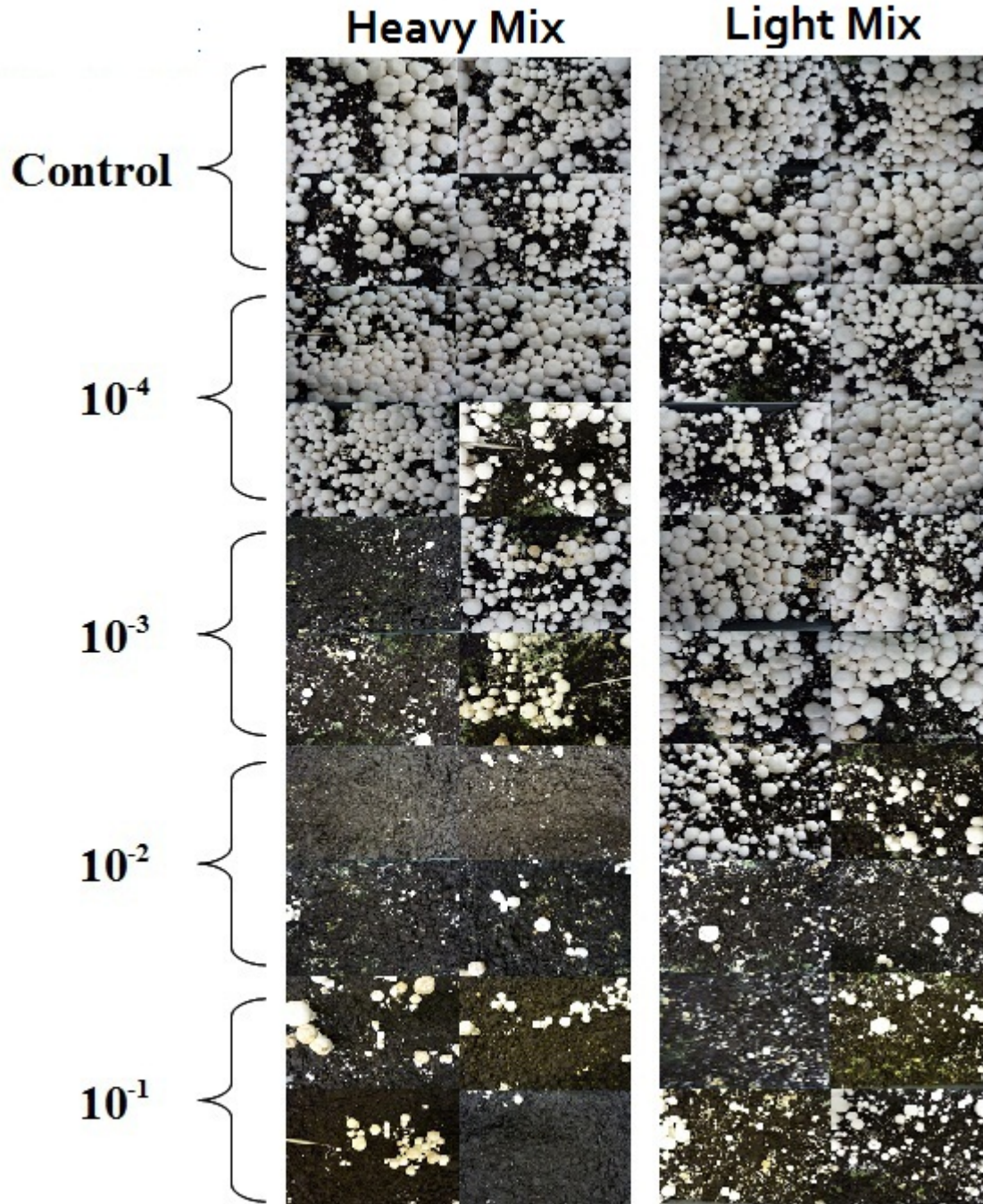

Fig. 4.5: Composite image of mushroom growth - experiment 3

4.3.4 Comparison of microbiological and molecular methods for quantifying *Trichoderma aggressivum* infection level in Bulk Phase III mushroom substrate

Four methods for the quantification and detection of *Trichoderma aggressivum* in Bulk Phase III substrate were compared. The effect of the addition of supplement on the detection methods was not considered, so the results from both sample sets from experiment 2 were combined. Samples from the unmixed treatment of experiment 3 were not tested, as it was assumed samples would not be representative.

Tables 4.5 and 4.6 show the qPCR, MPN and DPA results for substrate samples from cropping experiment 2 and cropping experiment 3, respectively. Due to the time consuming nature of weed mould analysis this method was only performed on the 10^{-2} and 10^{-4} dilution levels in experiment 2, results are shown in Table 4.5. DNA extraction and qPCR analysis were carried out by FERA (York) using SyBr fluorescence detection and primers targeting the TEF-1 gene sequence, the exact sequence of these primers is not disclosed.

The units for MPN and WMA counts are cfu/g and are log (base 10) transformed. Zero values were given a nominal value of 1 prior to transformation. Results for qPCR analysis are given in terms of crossing point (Cp), the number of cycles at which the signal intensity becomes greater than the background. Co-efficient of variation (CV) for all data was calculated by dividing the sample mean by the sample standard deviation. Co-efficient of variation for sample sets with a mean count of zero is denoted with nd because the CV is not defined.

Results were analysed by Pearson's correlation test. The WMA results were excluded because there were not enough data points for this type of analysis but ANOVA analysis showed them to be not significantly different to the MPN results ($P=0.11$). Significant correlation was observed between the results of each detection method and the infection level in both experiments. A negative correlation was observed for the qPCR analysis and a positive correlation was observed for the microbiological methods. This is because Cp in qPCR analysis is inversely proportional to the amount of *T. aggressivum* target DNA present in the sample, while microbiological counts are proportional to the amount of *T.*

aggressivum cells present.

A correlation matrix was generated to test the similarity of the response of each detection method and is shown in Table 4.7. The WMA results were again excluded due to lack of data points. For samples from experiment 2 qPCR and DPA results correlated significantly but the results for MPN analysis did not correlate well with either. This may be as a result of a larger number of negative results for this method at the 10^{-3} and 10^{-4} infection levels, which was not expected and did not correspond with the results for qPCR or DPA analysis in this experiment. When samples from experiment 3 were analysed each detection method gave results which were correlated significantly, indicating that each detection method responded similarly to *T. aggressivum* infection level.

Tab. 4.5: Detection of *Trichoderma aggressivum* in Bulk Phase III mushroom substrate by qPCR, MPN and DPA - experiment 2.

Treatment	qPCR		MPN		DPA		WMA	
	Mean ¹	CV	Mean ²	CV	Mean ³	CV	Mean ⁴	CV
10^{-1}	24	0.04	6.2	0.03	9.4	0.14	-	-
10^{-2}	27	0.03	4.8	0.15	6.8	0.42	4.3	0.28
10^{-3}	29	0.04	0.8	0.58	6.8	0.22	-	-
10^{-4}	35	0.02	0.0	n/a	1.7	0.61	0.1	0.58
Control	40	0.00	0.0	n/a	0.0	n/a	-	-
Pearson R	-0.98		0.94		0.96		-	
R ²	0.97		0.88		0.92		-	
P value	0.002		0.018		0.009		-	

¹ Cp, ² logcfu/g, ³ pieces positive of ten, ⁴ logcfu/g

Tab. 4.6: Detection of *Trichoderma aggressivum* in Bulk Phase III mushroom substrate by qPCR, MPN and DPA - experiment 3.

Treatment	qPCR		MPN		DPA	
	Mean ¹	CV	Mean ²	CV	Mean ³	CV
10 ⁻¹	28	0.06	6.52	0.11	9.50	0.06
10 ⁻²	32	0.05	3.04	0.75	7.50	0.44
10 ⁻³	37	0.09	2.55	0.20	2.50	0.52
10 ⁻⁴	40	0.00	0.00	n/a	0.25	2.00
Control	40	0.00	0.00	n/a	0.00	n/a
Pearson R	-0.95		0.95		0.96	
R ²	0.90		0.89		0.92	
P value	0.014		0.015		0.009	

¹ Cp, ² logcfu/g, ³ pieces positive of ten

Tab. 4.7: Correlation analysis of methods used for the detection of *T. aggressivum*.

		Pearson R			P value		
		qPCR	MPN	DPA	qPCR	MPN	DPA
Experiment 2	qPCR	-	-0.87	-0.98	-	0.055	0.003
	MPN	-0.87	-	0.82	0.055	-	0.092
	DPA	-0.98	0.82	-	0.003	0.092	-
Experiment 3	qPCR	-	-0.96	-0.99	-	0.010	0.002
	MPN	-0.96	-	0.93	0.010	-	0.023
	DPA	-0.99	0.93		0.002	0.023	-

4.4 Discussion

4.4.1 The effect of substrate infection rate, supplementation and mixing on mushroom yield in *Trichoderma aggressivum* infected crops

The aim of the presented work was to increase our understanding of how *Trichoderma aggressivum* affects Bulk Phase III production systems if a small volume of substrate becomes infected at spawning, colonised by *T. aggressivum* and then get mixed throughout a larger volume of uninfected Phase III substrate during bulk handling. It was shown that healthy Bulk Phase III substrate is vulnerable to infection by *T. aggressivum* during the bulk handling stage. The severity of subsequent crop losses is proportional to the quantity of substrate which is infected as well as the *T. aggressivum* fungal load in the infected substrate and the degree of mixing. The addition of a supplement at bulk handling was not shown to affect the severity of *T. aggressivum* infection.

The more severe impact of *T. aggressivum* infection in experiment 2 was unexpected. While the number of *T. aggressivum* propagules in the inoculum was higher than in experiment 1 the reduction in mushroom yield was not proportional, in fact the mushroom yield from the least infected plots in this experiment was on average less than that from the highest infection level in experiment 1. It was hypothesised that the manner in which the substrate was mixed may have had a role in exacerbating the action of *T. aggressivum*. Experiment 3 was designed to test this hypothesis.

The results of experiment 3 show that a more thorough mixing of infected and uninfected Phase III substrate results in greater reductions in yield with the same inoculum. An interaction between the effects of infection level and mixing on yield was observed. This suggests that mixing exacerbates the effect of *T. aggressivum* more significantly the higher the initial infection level.

One hypothetical explanation for these results is that mixing of spawn-run Bulk Phase III substrate puts *Agaricus bisporus* under stress, making it more susceptible to *T. aggressivum*. Fully spawn run substrate is generally considered to be less susceptible to diseases, including *Trichoderma* green mould, due to the strong presence of *A. bisporus* mycelium (Seaby, 1987; Rinker, 1997). At the end of the Phase III process the substrate is very thoroughly colonised by *A.*

bisporus which makes access more difficult for other microbes. However when Bulk Phase III substrate is bulk handled during tunnel emptying and transport this may present an opportunity for *T. aggressivum* to infect the substrate which does not occur when the substrate is spawn-run *in situ*. If the ability of *A. bisporus* to exclude competitors from the substrate is linked to the integrity of its mycelium then it is likely that bulk handling and the disruption of the *A. bisporus* mycelium might facilitate colonisation by *T. aggressivum*. It has been shown that metabolites produced by *A. bisporus* have a stimulatory effect on the growth of *T. aggressivum* (Mumpuni *et al.*, 1998). Breaking the *A. bisporus* hyphae in Bulk Phase III substrate may also cause the release of more of these metabolites, thus stimulating the *T. aggressivum* to grow, but further study in this area is required to test this hypothesis.

Another hypothetical explanation is that the transfer of *T. aggressivum* spores or mycelium from infected substrate to uninfected substrate due to mixing results in more rapid colonisation of the substrate by *T. aggressivum*. Fully infected substrate exhibits a high load of *T. aggressivum* propagules per gram, in the order of 10^8 - 10^9 , with the majority of these colony-forming-units almost certainly being conidia rather than hyphae, based on the visible green colouration of the infected substrate. Spores of *T. aggressivum* are known to be able to germinate in mushroom substrate colonised by *A. bisporus*, but the growth of *T. aggressivum* is relatively slow in non-sterilised substrate (Largeteau *et al.*, 2000b). It is possible that mixing results in a lower level of infection across a larger area of substrate which is then colonised by germinating *T. aggressivum* spores, resulting in more severe crop losses. Further study is required to test this hypothesis as the relative importance of spore germination and mycelial growth in this type of *T. aggressivum* infection is not known.

4.4.2 Detection of *Trichoderma aggressivum* in Bulk Phase III mushroom substrate

Four methods for the detection and/or enumeration of *Trichoderma aggressivum* in mushroom substrate were tested and compared. Three of the methods were microbiological in nature and culture dependent, one method was a culture independent qPCR method.

Of the two microbiological counting methods (MPN and WMA) it was determined that there was no significant difference in their ability to enumerate *T. aggressivum* in substrate (P=0.11). The MPN method is widely used as an alternative to traditional colony counting methods (Garthright & Blodgett, 2003) and based on these data is a time-saving alternative to full weed mould analysis. Both methods returned false negative results at lower infection rates and displayed increases in the co-efficient of variation as the concentration of infected substrate decreased. This is likely due to the heterogeneous nature of mushroom substrate and is discussed below.

The direct plating assay (DPA) is a very simple method of determining the presence or absence of *T. aggressivum* in bulk handled Phase III substrate and also gives an indication of the severity of infection. The number of pieces of substrate showing growth of *T. aggressivum* is related to the infection rate (P<0.0001). However, the co-efficient of variation for this test also increased in the more dilute the infection levels, similar to the other two growth dependent detection methods. This method had the lowest number of false negative results of those tested and was the only method to detect *T. aggressivum* at the lowest level of infection in Experiment 3 although, only in one sample four. Considering these factors the direct plating assay represents a surprisingly attractive option for the detection of *Trichoderma* in bulk handled Phase III substrate when enumeration is not essential.

Quantitative PCR was the most technologically advanced method used to enumerate *T. aggressivum* infection in this study. In these experiments this method was more sensitive than the two microbiological counting methods and could detect *T. aggressivum* at the 10^{-4} level in experiment 2, but returned negative results at this dilution in experiment 3, where the amount of *T. aggressivum* in the inoculum was an order of magnitude lower. The problem of increasing variation between samples was not observed with qPCR, the co-efficient of variation remained largely constant, regardless of the dilution level. Quantitative PCR is the fastest method, results can be obtained on the day of processing, and it allows direct measurement of *T. aggressivum*, whereas the other methods are dependent on subsequent PCR testing for species identification. However, unlike culture dependent methods this method does not distinguish between living and dead

cells and this should be taken into account when interpreting results.

The most significant challenge to the accurate enumeration of *T. aggressivum* in Bulk Phase III substrate may be sampling. Each method of *T. aggressivum* enumeration other than qPCR showed increasing variability with reduced infection level, which suggests that the *T. aggressivum* is not evenly distributed in the substrate after mixing. Results from the direct plating assay show that there is a transfer of *T. aggressivum* between infected and uninfected substrate straws, but that it is much less efficient than dispersal would be in a liquid medium, for example. The higher reliability of the qPCR method at low infection levels may be in part due to the larger sample size processed. The total 100 g of substrate was tested by qPCR whereas 20 g was used for MPN and WMA and individual straws are tested using DPA.

Although it was the most sensitive technique using qPCR did not reliably detect *T. aggressivum* in the lowest infection level in experiment 3, even though the mean spore load in the substrate was in the order of 10^4 cfu/g. This is likely a result of non-homogenous distribution of *T. aggressivum* infected substrate and *T. aggressivum* propagules within the total volume of substrate.

In order to determine the average concentration of cells in a volume of substrate it is necessary to assume that the cells are evenly distributed and equally likely to be present in any subsample selected randomly from the whole (Gy, 2004a,b,c). It is clear from these results that are inherent problems in obtaining a representative sample of Bulk Phase III substrate through mixing alone. In the Bulk Phase III system mixing of spawn-run substrate is undesirable as it damages the *Agaricus bisporus* mycelium, so samples taken from an industrial facility are likely to be of a similarly heterogenous nature to those tested in this work.

Representative sampling is key to the determination of the concentration of a given species within a population without sampling the entire population. That is to say, if a sample is taken from any mass of material and subjected to a test the measurement thereby obtained is only true for the sample tested, and in order to extrapolate the measurement to the whole mass it is necessary to assume that the sample contains the exact same constituent as the whole mass, in the same proportions (Petersen *et al.*, 2004). This assumption is key to any destructive sampling technique, like those used above, because it is not possible to sample

the whole population.

The assumption that a sample is representative is usually valid for liquids since they can be mixed effectively to produce homogeneous solutions, for many biological assays the contribution of sampling error to total error is minimal because the material tested is naturally homogenous (Esbensen & Heydorn, 2004). Mushroom substrate is a solid made of large, irregularly shaped particles which makes attaining a representative sample by mixing much more difficult (Petersen *et al.*, 2005). There is an additional barrier to the sampling of Phase III mushroom substrate, in that most methods for accurate mass reduction would completely destroy the *A. bisporus* mycelium (Thy *et al.*, 2009; Petersen *et al.*, 2005). It is possible to deal with this sort of problem statistically but it would first be necessary to estimate the level of heterogeneity in the substrate empirically (Minkkinen, 2004; Tønning *et al.*, 2006).

5. INTERSPECIFIC MOLECULAR AND CHEMICAL VARIATION IN *TRICHODERMA* ISOLATES

5.1 *Identification of fungi using PCR*

Polymerase chain reaction has become a core process in molecular biology since it was first described in the 1980s (Mullis *et al.*, 1986), to the extent that the two terms are practically synonymous. PCR dependent molecular analyses such as AFLP, RAPD-PCR and comparative sequence analysis are increasingly the standard methods for differentiating micro-organisms with similar morphological characteristics (Domig *et al.*, 2003). Comparative sequence analysis of the internally transcribed spacer region of the rDNA (ITS ribotyping) is a particularly common tool in the classification of fungi and other microbes (Blanc *et al.*, 1999; Chen *et al.*, 1999b). The ribosomal DNA is conserved at a genus or higher level, but the ITS region is relatively variable. This means that the region can be amplified using the same set of primers for multiple species and then sequenced to identify small differences between them (Ospina-Giraldo *et al.*, 1999; Lu *et al.*, 2000).

If the sequence for the ITS region (or any other gene) displays specific sequences which are conserved at species level, but not higher, then PCR using primers complimentary to those sequences can be used to identify fungal species directly. Species specific PCR is a rapid and effective method for the detection and identification of fungal species. Chen *et al.* (1999a) developed a set of selective primers for *T. aggressivum* based on a RAPD product which was observed in *T. aggressivum* but not other *Trichoderma* strains. These primers amplify the same region of both *T. aggressivum* subspecies which can be distinguished from each other by restriction digest of the product, due to a small amount of polymorphism within the amplified sequence (Staniaszek *et al.*, 2010). An additional set

of primers for the identification of both *T. aggressivum* subspecies was developed at Warwick HRI based on the ITS region (Grogan, pers. comms).

Quantitative real-time PCR allows not only for the detection and identification of fungal species, but also estimation of the amount of that species within a population or sample. In this study, a quantitative real-time PCR assay specific for *T. aggressivum* was developed. Different DNA extraction methods were compared for their suitability for the purification of PCR amplifiable DNA from *Trichoderma* cultures and mushroom substrate. Existing species specific primers were tested for their suitability in qPCR, and novel primer sets were designed based on sequence analysis of published *T. aggressivum* genes. The efficiency and specificity of published and novel *T. aggressivum* specific primers were compared using a panel of *Trichoderma* specimens containing aggressive and non-aggressive isolates (Table 2.1).

5.1.1 Differentiation of fungi based on secondary metabolite profiles

Secondary metabolites are gene products not directly associated with cell growth or metabolism, many of which are bioactive molecules such as antibiotics and toxins (Mukherjee *et al.*, 2012). Fungal species differ in the type, number, and relative quantity of secondary metabolites they produce (Keller *et al.*, 2005). The study of secondary metabolite production is described as metabolite profiling, or metabolomics.

The degree to which the production of secondary metabolites varies between two fungal species depends on the taxonomic relatedness of the species (Keller *et al.*, 2005), as a result metabolite profiling can be used as an alternative method for species classification, this is called chemotaxonomy. Chemotaxonomy has been applied to *Trichoderma* classification previously (Kang *et al.*, 2011), producing similar phylogenetic groupings as molecular analyses. Thrane *et al.* (2001) and Kang *et al.* (2011) showed that *Trichoderma aggressivum* was taxonomically distinct from *Trichoderma harzianum* and other related species by LC/MS, GC/MS and UPLC/Q-TOF-MS. Thrane *et al.* (2001) described the identification of *Trichoderma* species by comparative analysis of HPLC metabolite profiles, but *T. aggressivum* was not included in their study.

In this study comparative analysis of HPLC metabolite profiles was assessed

as a method for the identification *T. aggressivum* and differentiation of *T. aggressivum* from non-aggressive *Trichoderma* species. The use of secondary metabolite production to identify *T. aggressivum* is attractive because secondary metabolites produced by *T. aggressivum* are known to be antagonistic toward *Agaricus bisporus* (Krupke *et al.*, 2003) and as such metabolite profile may be a good indicator of the mushroom-aggressive phenotype.

5.2 Evaluation of DNA extraction methods for the purification of PCR amplifiable DNA from *Trichoderma* cultures

5.2.1 Manual DNA extraction by salt precipitation

Genomic DNA was extracted from 3 day liquid cultures of *Trichoderma aggressivum* grown in malt extract broth as per the method of Aljanabi & Martinez (1997) (Section 2.1, 2.6.1). This method yielded large amounts of high molecular weight DNA (Figure 5.1 A) but in some cases the DNA was degraded (5.1 B). This method also co-purified RNA along with DNA so the addition of RNase A during the lysis step proved necessary.

DNA was PCR amplifiable, with A 260/280 values of 1.8-2.0 (closer to 1.8 when RNase was used). Quantification by spectrophotometry was unreliable due to the presence of degraded DNA which had to be assessed by gel electrophoresis. As a result this method was less suitable for the extraction of DNA for real-time PCR analysis. Due to the large volume of mycelium required this method was not suitable for the extraction of DNA from mycelium harvested from solid cultures but due to ease of scale up it is useful when high quantities of DNA are desired.

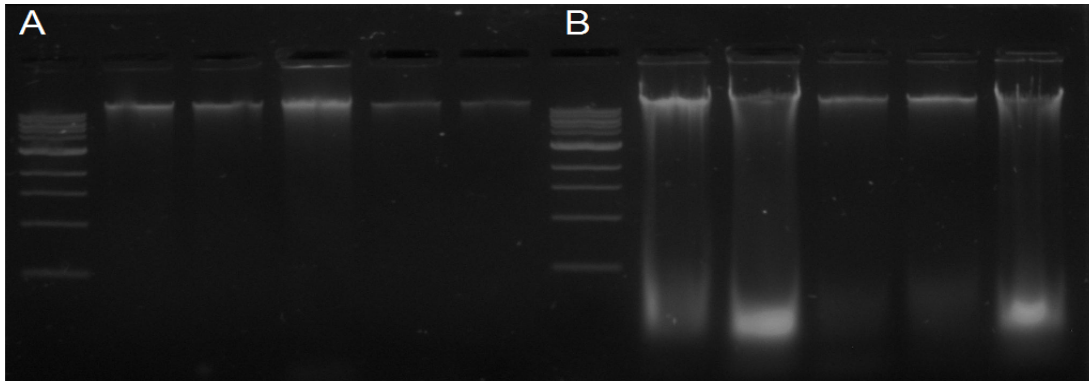

Fig. 5.1: EtBr gel of genomic DNA extracted by Aljanabi & Martinez (1997) method.

5.2.2 DNA extraction with Qiagen Plant DNeasy spin kit (®)

DNA was extracted from 3 day liquid cultures of *Trichoderma aggressivum* grown in malt extract broth (Section 2.1, 2.6.1). This method yielded high molecular weight DNA with little break-down visible by gel electrophoresis (Figure 5.2 A). DNA concentration and purity, as determined by NanoDrop spectrophotometry, were high although the A 260/230 ratio was variable due to impurities absorbing at 230 nm. Carbohydrate based contaminants are the most common which absorb at this wavelength and they do not interfere with PCR.

This method was also used for the extraction of DNA from lyophilised Bulk Phase III mushroom substrate but yielded no DNA (Figure 5.2 B).

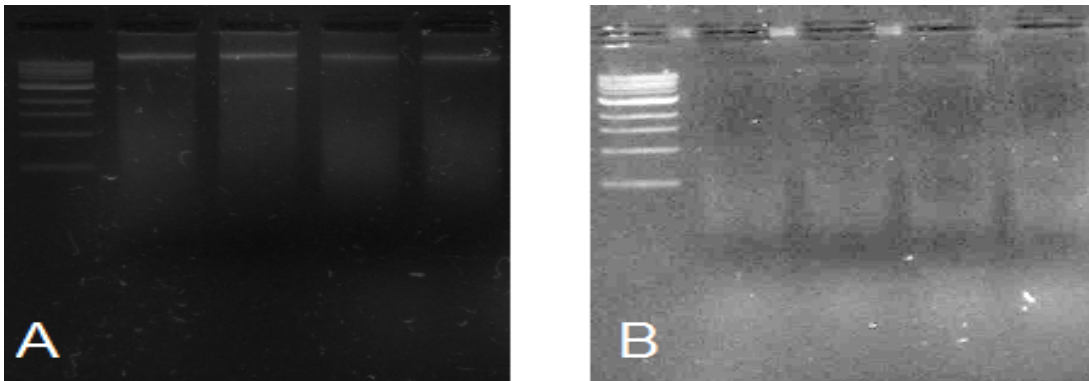

Fig. 5.2: DNA extract by Qiagen Plant Genomic method from *T. aggressivum* mycelium (A) and colonised Bulk Phase III mushroom substrate (B).

5.2.3 DNA extraction with Sigma Plant Genomic DNA extraction kit (®)

DNA was extracted from 3 day liquid cultures of *T. aggressivum* grown in malt extract broth and 3 day solid cultures grown on malt extract agar using methods described in Sections 2.1 and 2.6.1. This method produced high molecular weight DNA with no visible degradation (Figure 5.3 A). DNA concentration was generally lower for solid cultures than liquid cultures but was still acceptable. RNA contamination was rare but the addition of RNase A to the lysis buffer removed RNA completely. NanoDrop spectrophotometry showed the DNA to have an A 260/280 ratio within the range of pure DNA (1.8-1.9). Carbohydrate contamination was present as for the Qiagen kit but it did not interfere with PCR.

This method was also used for the extraction of DNA from lyophilised Bulk Phase III mushroom substrate. A small amount of DNA was obtained (Figure 5.3 B) which was amplified by standard PCR using *T. aggressivum* selective primers. No product was observed after amplification suggesting that template concentration was too low or PCR inhibitors were co-purified with the DNA (Figure 5.3 C).

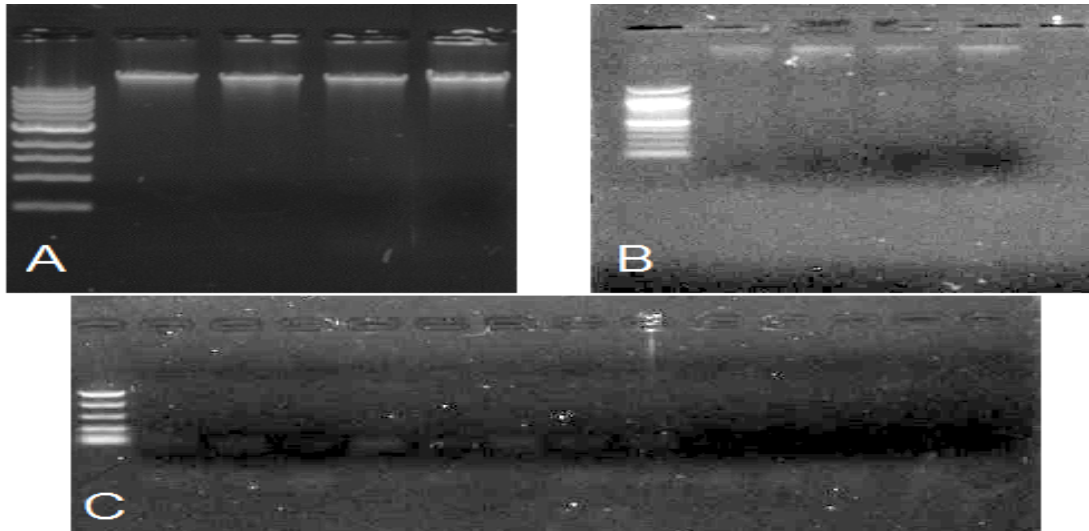

Fig. 5.3: DNA extract by Sigma Plant Genomic method from *T. aggressivum* mycelium (A), colonised Bulk Phase III mushroom substrate (B) and PCR product of mushroom substrate extract (C).

5.2.4 DNA extraction with Promega Wizard Magnetic Food DNA extraction kit

DNA was extracted from *Trichoderma* mycelium and spore suspensions of *T. aggressivum* using methods described in Sections 2.1 and 2.6.1. Extraction from mycelium yielded high molecular weight DNA with little to no break-down product. The A₂₆₀/A₂₈₀ ratio was high in some cases but this can occur due to the presence of a small number of magnetic beads in the purified sample. No RNA contamination was observed on gel electrophoresis (Figure 5.4 A). Extraction from spore suspension yielded no DNA (Figure 5.4 B).

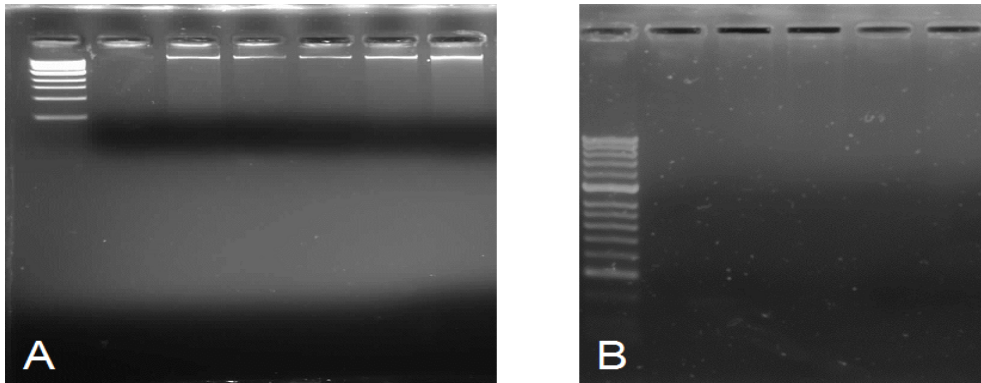

Fig. 5.4: DNA extract by Promega Magnetic method from *T. aggressivum* mycelium (A) and spore suspension (B)

5.2.5 DNA extraction with Chemagen Chemagic Food DNA extraction kit

DNA was extracted from *Trichoderma aggressivum* mycelium, spore suspensions and lyophilised Bulk Phase III mushroom substrate. Extraction from mycelium yielded high molecular weight DNA with a small amount of breakdown product. Extraction from a spore suspension yielded no DNA. Extraction from Bulk Phase III mushroom substrate yielded DNA which was heavily degraded and contained a high level of impurities (Figure 5.5).

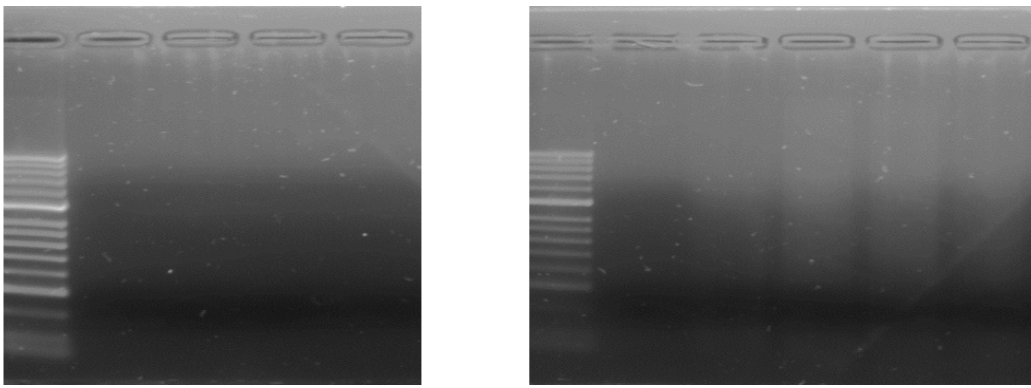

Fig. 5.5: DNA extract by Chemagen Magnetic method from *T. aggressivum* spore suspension (Left) and colonised Bulk Phase III mushroom substrate (Right).

5.2.6 DNA extraction with ZR Fungal/ Bacterial DNA extraction kit

DNA was extracted from *Trichoderma aggressivum* mycelium grown in liquid culture and ground in liquid nitrogen. This method yielded high concentrations of high molecular weight DNA with no visible breakdown or RNA contamination (Figure 5.6). The purity of DNA obtained with this method was high ($A_{260}/A_{280} \sim 1.80$) and no carbohydrate contamination was observed by spectrophotometry.

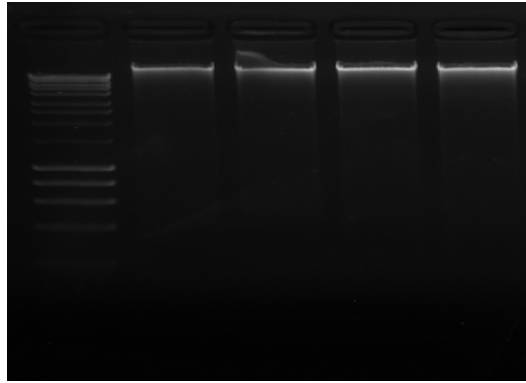

Fig. 5.6: EtBr gel of Genomic DNA extracted with ZR Fungal/ Bacterial DNA extraction kit

5.2.7 Summary

DNA extraction procedures were assessed for their suitability for use with *T. aggressivum*. They included one manual method, 3 column based commercial kits and 2 magnetic-bead based commercial kits.

The manual method had the advantage of being able to process a large amount of material but it was the most time consuming method and produced DNA which was sheared in some cases. This method is suitable when a large quantity of DNA is required and integrity is not essential.

The three column based kits were less time-consuming and yielded higher integrity DNA. The Sigma and ZR kits produced DNA of higher integrity than the Qiagen kit. The Sigma extraction kit allowed extraction of DNA from solid cultures, which was the most convenient method for rapid species identification. The ZR kit was the fastest column based method and produced the highest concentration of DNA, making it more suitable for DNA intensive down-stream processes.

The magnetic-bead based extraction methods were the least time consuming, with the Promega kit allowing slightly faster sample processing than the Chemagen kit. When DNA was extracted from mycelium grown in liquid culture both methods yielded decent quantities of DNA, but the Chemagen kit produced DNA which was degraded to some extent. Since the lysis step for neither kit relies on mechanical disruption they were tested from their ability to extract DNA from liquid suspensions of *T. aggressivum* spores, but neither yielded workable amounts of DNA from this sample type.

Three methods were tested for their suitability in extracting DNA from Bulk Phase III mushroom substrate, but none was successful. The Qiagen kit yielded no quantifiable amount of DNA from this sample type. The Sigma kit yielded a very small quantity of DNA which was of high molecular weight, but also co-purified PCR inhibitors from the substrate which prevented down-stream processing of the DNA. The Chemagen kit successfully extracted some DNA from the substrate but it was heavily degraded and contained a high level of impurities, rendering it unsuitable for PCR.

5.3 Sequence analysis and novel selective primers

All available gene sequences for *T. aggressivum* were retrieved from GenBank (<http://www.ncbi.nlm.nih.gov/genbank/>). A nucleotide BLAST search was performed for each of these genes to determine the degree of sequence conservation with other species. The translation elongation factor 1 alpha (*tef1*) gene was selected based on its greater degree of sequence divergence with other *Trichoderma* species and published material (Samuels *et al.*, 2002; Komon-Zelazowska *et al.*, 2007; Kredics *et al.*, 2009; Błaszczyk *et al.*, 2011). Other genes considered for primer design were ITS-1, ITS-2, RNA polymerase II subunit and calmodulin.

A high similarity MegaBLAST search of the GenBank Nucleotide (nr/nt) database using the *tef1* gene as the query sequence reveals varying degrees of sequence homology with other *Trichoderma* isolates (Figure 5.8, 5.7). The most similar sequences are those from other *T. aggressivum* f. *europaeum* strains followed by *T. aggressivum* f. *aggressivum*, *Trichoderma harzianum* and other related species.

Blast alignment of the *tef1* gene from *Trichoderma aggressivum* f. *europaeum* strains CBS 100526 and CBS 433.95 (accession numbers AF348096.1 and AF348097.1, respectively) showed them to be identical sequences. Primers were designed using the *tef1* sequence from CBS 100526 (Fig 5.1).

Tab. 5.1: Nucleotide sequence of *tef1* gene from *T. aggressivum* strain CBS 100526

CBS 100526 <i>tef1</i>						
1	ctaccagtgc	ggtggtatcg	acaagcgtac	catcgagaag	ttcgagaagg	taagcgccaa
61	ctgactttcg	cctcgattct	ccctccacat	ccaattgtgc	tcgatcattc	tgaagagaat
121	tgtcgacaat	ttttcatcac	cccgetttcc	attaccctc	ctttgcagcg	acacaagatt
181	ttttttgctg	tcgtttggtt	ttagtggggg	tccttgtgca	ccccactag	ctcactgctt
241	tttttttg	cttactatc	actaccgagc	cgtcgttcaa	cgtgctctgt	ctctcgtcat
301	ccagtgatgc	taaccacttt	ttccatcaat	aggaagccgc	cgaactcggc	aagggttctt
361	tcaagtacgc	ttgggttctt	gacaagctca	aggccgagcg	tgagcgtggt	atcaccatcg
421	acattgcct	ctggaagttc	gagactccca	agtactatgt	caccgtcatt	ggtatgtctc
481	cttcatcacc	ccgatgcagc	aattacaagc	cagtgctaac	aggcaattca	cagacgctcc
541	cggccaccgt	gattttatca	agaacatgat	cactggtact	tcccaggccg	attgcgctat
601	cctcatcatt	gccgccgta	ctggtgag			

Fig. 5.7: MegaBlast search sequence alignment of genes homologous with *T. aggressivum* tef1.

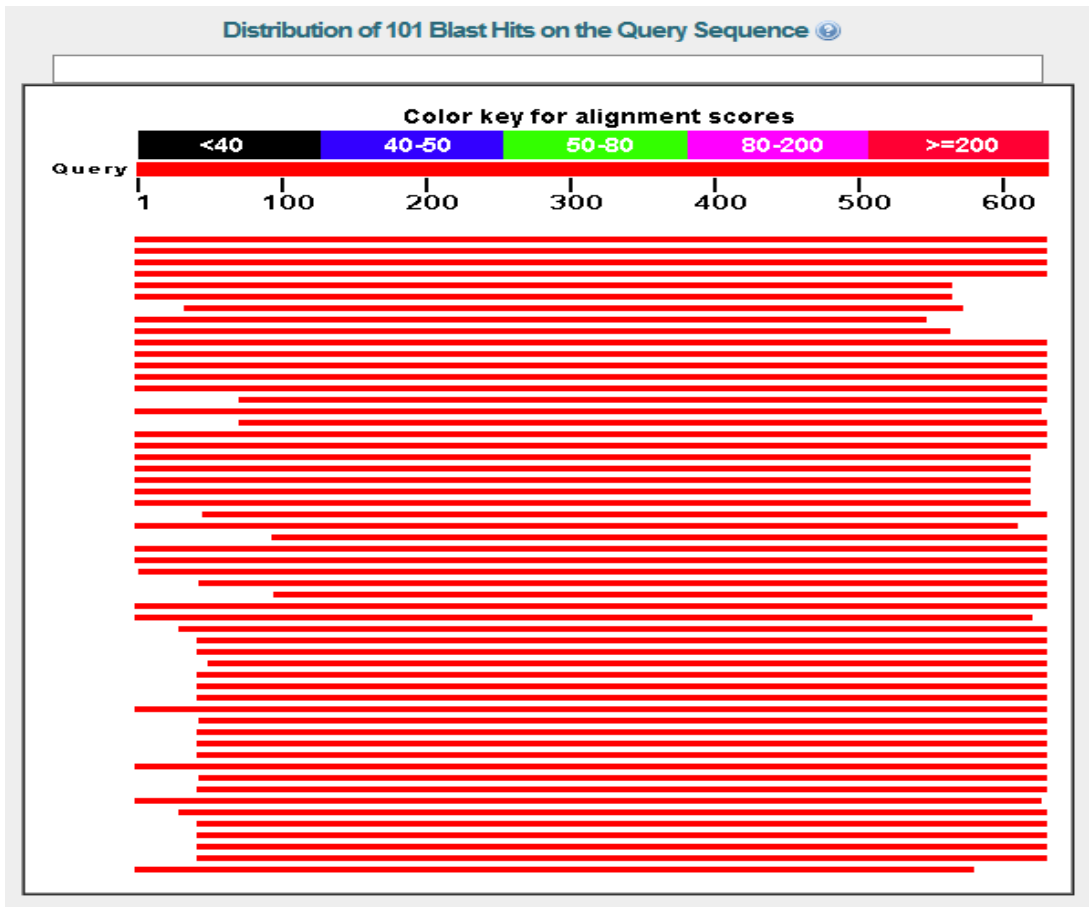

Each red bar represents an accession with sequence similarity, the length and position of bars indicates areas of homology. Accession details given in Figure 5.8.

Fig. 5.8: Sequences aligning with *T. aggressivum* tef1 query sequence.

Sequences producing significant alignments:

Accession	Description	Max score	Total score	Query coverage	Max ident
AF348089.1	Trichoderma aggressivum f. europaeum isolate CBS 689.94	1160	1160	100%	100%
AF348095.1	Trichoderma aggressivum f. europaeum isolate CBS 100525	1160	1160	100%	100%
AF348094.1	Trichoderma aggressivum f. aggressivum isolate GJS 99-29	1127	1127	100%	99%
AF348098.1	Trichoderma aggressivum f. aggressivum isolate DAOM 2221	1127	1127	100%	99%
AY605798.1	Trichoderma aggressivum f. aggressivum strain DAOM 2221	1007	1007	89%	99%
AY605794.1	Trichoderma aggressivum f. aggressivum strain DAOM 2221	1007	1007	89%	99%
FJ467645.1	Trichoderma aggressivum strain CBS 689.94 translation elongation factor	983	983	85%	99%
AY605795.1	Trichoderma aggressivum f. aggressivum strain DAOM 2221	979	979	86%	99%
AY605758.1	Trichoderma sp. DAOM 229901 translation elongation factor	867	867	89%	95%
AF348093.1	Hypocrea lixii isolate GJS 99-227 translation elongation factor	848	848	100%	91%
AF348092.1	Hypocrea lixii isolate IMI 359823 translation elongation factor	846	846	100%	91%
AF348101.1	Hypocrea lixii isolate CBS 226.95 translation elongation factor	846	846	100%	91%
AF348108.1	Hypocrea lixii isolate GJS 99-231 translation elongation factor	845	845	100%	91%
AF348107.1	Hypocrea lixii isolate GJS 99-230 translation elongation factor	845	845	100%	91%
EU498322.1	Hypocrea epimyces strain CPK2487 translation elongation factor	839	839	88%	94%
EF191330.1	Hypocrea lixii strain JB NZ12 translation elongation factor 1	839	839	99%	91%
EU498320.2	Hypocrea epimyces strain CBS120534 translation elongation factor	837	837	88%	94%
AF348100.1	Hypocrea lixii isolate CBS 227.95 translation elongation factor	835	835	100%	91%
AF348104.1	Hypocrea lixii isolate NR 6931 translation elongation factor	832	832	100%	91%
EF392751.1	Hypocrea lixii strain DAOM 233353 translation elongation factor	826	826	98%	91%
EF392750.1	Hypocrea lixii strain DAOM 233987 translation elongation factor	826	826	98%	91%
EF392749.1	Hypocrea lixii strain DAOM 233986 translation elongation factor	826	826	98%	91%
EF191337.1	Hypocrea lixii strain JB RO111 translation elongation factor	826	826	98%	91%
EF191335.1	Hypocrea lixii strain JB PER42 translation elongation factor	826	826	98%	91%
FJ463384.1	Trichoderma aggressivum strain Dis 53A translation elongation factor	813	813	92%	92%
EF191332.1	Hypocrea lixii strain JB NZ72 translation elongation factor 1	809	809	96%	91%
EU498321.1	Hypocrea epimyces strain CPK2417 translation elongation factor	808	808	85%	94%
AF348103.1	Hypocrea lixii isolate NR 6929 translation elongation factor	808	808	100%	90%
AF348099.1	Hypocrea lixii isolate CBS 273.78 translation elongation factor	806	806	100%	90%
JQ040412.1	Hypocrea lixii strain GYHB1005 translation elongation factor	804	804	99%	90%
FJ463382.1	Hypocrea lixii strain CBS 257.62 translation elongation factor	804	804	92%	92%
EU498319.1	Hypocrea epimyces strain CPK1980 translation elongation factor	804	804	84%	94%
AF348102.1	Trichoderma pleuroticola isolate GJS 95-81 translation elongation factor	802	802	100%	90%

Figure shows 33 most similar sequences (of 101). Alignment shown in Figure 5.7.

PrimerQuest software (<http://eu.idtdna.com/Scitools/Applications/Primerquest>) was used to design specific primers based on the *tef1* sequence. Primers were designed with the desired parameters of amplicon length 100-150 bp, primer length 20-25 bp, melting temperature 55-60 °C, no secondary structure, no self-complementary regions and primer pair melting temperatures not to differ by more than 1.5 °C. The designed primers were named according to the first complementary base in the target sequence and are listed in Table 2.7.

Primer specificity was assessed *in silico* by performing a BLAST search using the primer base sequence as the query sequence. The first five results for each primer, their coverage and identity are summarised in Table 5.2.

The specificity of these primers for *T. aggressivum* according to *in silico* analysis is good, apart from reverse primer 199, which shows a high degree of specificity for *Trichoderma harzianum* also. The relative discriminatory ability of the primers is tested *in vitro* in Section 5.3.3.

5.3.1 Primer efficiency and standard curves

Genomic DNA was extracted from *T. aggressivum* strain CBS 100526 using the Promega Wizard Magnetic kit and DNA concentration was calculated by spectrophotometry using methods described in Sections 2.6.1 and 2.6.4. A four-fold dilution series was prepared from 4.00 ng/ µl to 9.76 fg/ µl and qPCR was carried out in triplicate as per (Section 2.6.8).

Crossing point (Cp) values for each concentration with each set of primers was determined using the 2nd derivative max method. Standard curves and efficiencies were calculated automatically using the Roche Lightcycler software and are presented in Figure 5.9.

Amplifications efficiencies were 2.19, 1.97, 2.17, 1.93 and 2.00 for primer sets 41+180, 43+199, 44+199, THF+THR and 18SInt+THI Int rev, respectively. Each standard curve had an error value below the accepted 0.2.

Tab. 5.2: *In silico* analysis of primer specificity.

Primer	Sequences matched	Query coverage %	Max identity %
41	<i>T. aggressivum</i> f. <i>europaeum</i> tef1	100	100
	<i>T. aggressivum</i> f. <i>aggressivum</i> tef1	100	100
	<i>Trichoderma</i> sp. DAOM 229901 tef1	100	96
	<i>Exophiala jeanselmei</i> elongation factor	79	100
	<i>Pseudomonas syringae</i> genomic sequence	95	100
180	<i>T. aggressivum</i> f. <i>europaeum</i> tef1	100	100
	<i>Trichoderma epimyces</i> tef1 like	83	100
	<i>T. aggressivum</i> f. <i>aggressivum</i> tef1	83	100
	<i>Flavobacteriaceae</i> bacterium genomic sequence	79	100
	<i>Trichoderma harzianum</i> tef1	66-83	95-100
43	<i>T. aggressivum</i> f. <i>europaeum</i> tef1	100	100
	<i>T. aggressivum</i> f. <i>aggressivum</i> tef1	100	100
	<i>Planctomyces limnophilus</i> genomic sequence	90	100
	<i>Candida tropicalis</i> MYA-3404 mRNA	85	100
	<i>Puccinia graminis</i> pyruvate carboxylase	80	100
199	<i>T. aggressivum</i> f. <i>europaeum</i> tef1	100	100
	<i>T. aggressivum</i> f. <i>aggressivum</i> tef1	100	100
	<i>Trichoderma harzianum</i> (2 strains) tef 1	100	100
	<i>Mustela putorius</i> mitochondrial sequence	85	100
	<i>Trichoderma harzianum</i> tef 1	100	95
44	<i>T. aggressivum</i> f. <i>europaeum</i> tef1	100	100
	<i>T. aggressivum</i> f. <i>aggressivum</i> tef1	100	100
	<i>Planctomyces limnophilus</i> genomic sequence	90	100
	<i>Candida tropicalis</i> MYA-3404 mRNA	85	100
	<i>Beijerinckia indica</i> genomic sequence	85	100

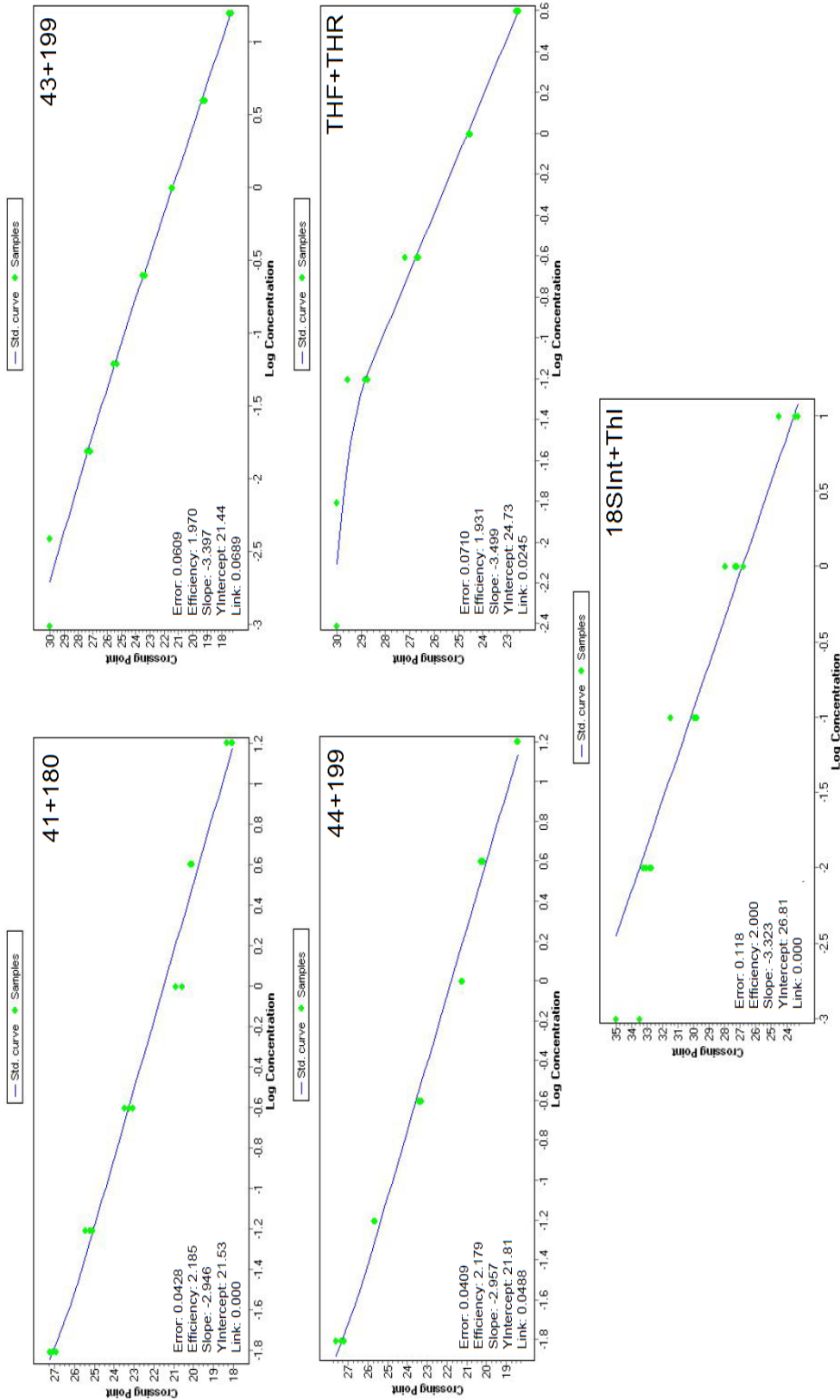

Fig. 5.9: Standard curves of *T. aggressivum* DNA amplified with novel and existing primers

5.3.2 Melt curve analysis

After amplification, melt curve analysis was performed on PCR products from Section 5.3.1 to assess the specificity of the PCR reaction. This analysis works by heating the PCR product until it becomes fully single stranded and SyBr fluorescence is removed. Non-specific PCR products can be discriminated from specific products on the basis of melting temperature, since the melting temperature of an oligonucleotide depends on base sequence.

Melt curves were transformed by differentiation to produce melting peaks, which displays a peak at the temperature at which half of the DNA molecules in the sample have become single stranded (T_m). Melting peaks for the products of each primer set are shown in Figure 5.10.

Primer set 18SInt+THI Int rev shows an irregular melt curve. DNA electrophoresis of this product did not show multiple bands so the unusual melt curve was attributed to the large size of the amplicon generated (~ 800 bp). Amplicon sizes greater than 200 bp are generally considered unsuitable for real-time PCR, partially because a large amplicon does not become single stranded rapidly across a narrow temperature range, instead regions of the amplicon can become single stranded at a range of different temperatures according to local CG content. Melt curve analysis cannot be reliably performed on primers with large amplicon size and the reaction specificity cannot be determined directly from the results of real-time PCR. Because of the large amplicon size produced by primer set 18SInt+ThI Int rev they were excluded from further real-time PCR analysis.

Primer set ThF+ThR amplify an arbitrary 444 bp section of the *T. aggressivum* genome. The melting peaks for these primers show the PCR product melting in two stages. The majority of the DNA becomes single stranded at ~ 85 °C with a smaller overlapping melt peak at ~ 83 °C. This makes these primers unsuitable for more advanced melt curve analysis, such as Melt-Curve genotyping or sequence differentiation by T_m calling, but the melt curve is probably characteristic enough to allow these primers to be used for basic real-time PCR.

The novel primers used in this study were designed specifically for real-time PCR and produce amplicons <150 bp in length for effective melt-curve analysis. No non-specific melt peaks were observed for any of the of the novel primer sets

and the melting curves were all of the expected shape. There was a slight increase in amplicon melting temperature with decreasing DNA template concentration, but this may occur ordinarily when this type of analysis is performed on serially diluted template (Filion *et al.*, 2003).

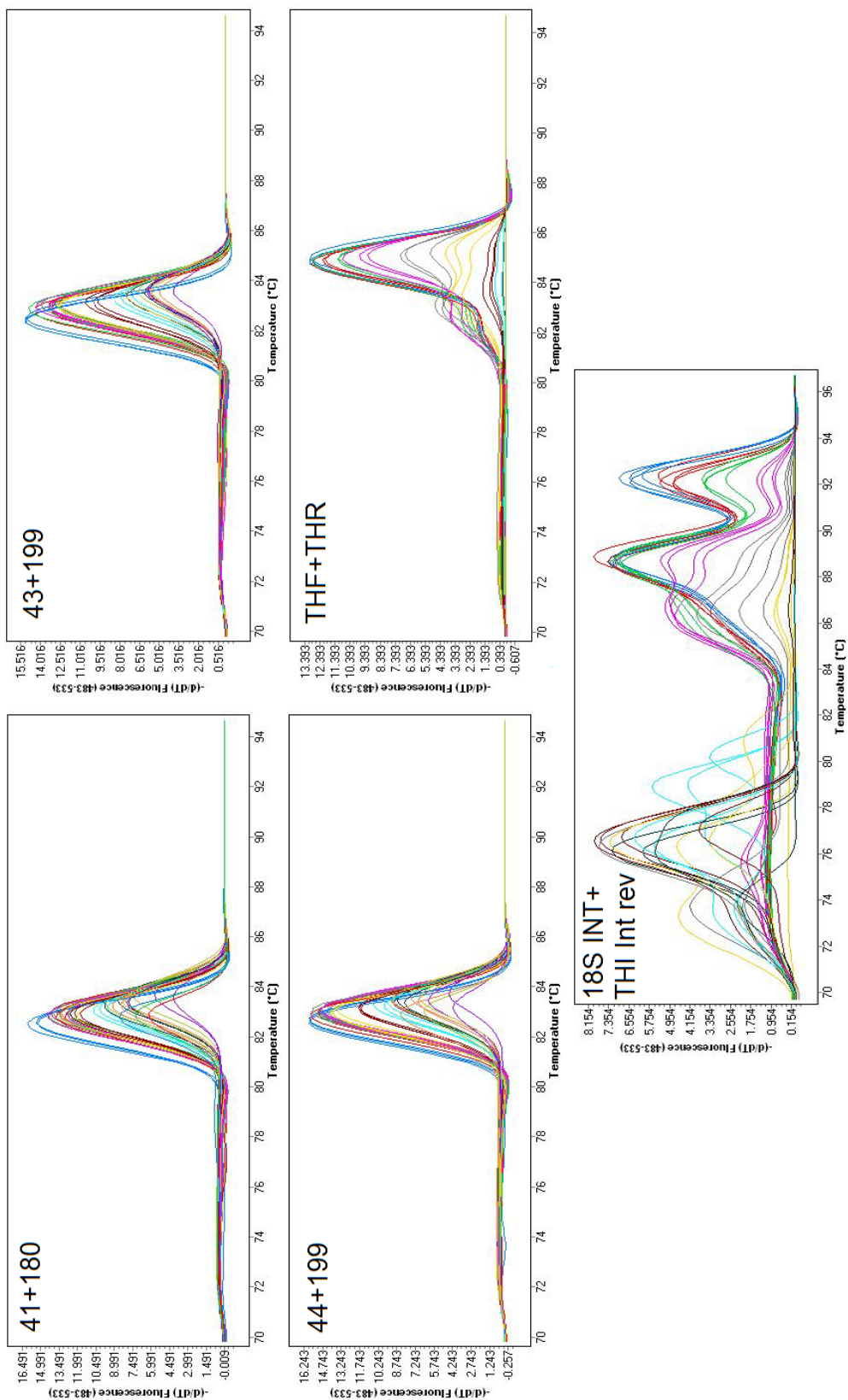

Fig. 5.10: Melt curve analysis of products from primer standard curves

5.3.3 Comparison of novel and existing primers for differentiating *Trichoderma* isolates

DNA was extracted from 15 *Trichoderma* isolates using the Promega Wizard magnetic kit (Section 2.6.1) and DNA concentration was adjusted to 1 ng/ μ l. Each of these isolates is a *Trichoderma harzianum*-like strain which was found growing on or near mushroom substrate and which were identified based on morphology and/or PCR. Species are listed in Table 2.1. For each isolate 4 μ l was used as template for real-time PCR analysis (Section 2.6.8). PCR was carried out in duplicate for 4 sets of primers with the annealing temperature adjusted to the optimum for each primer set. Following amplification Melt curve and T_m calling analysis were carried out on the PCR product.

The C_p values for each combination of primer set and isolate were calculated by the second derivative max method and are listed in Table 5.3. Average C_p values were subtracted from 30 (the total cycle number) to give a measure of the reactivity of each primer with each template (C_p') shown in Figure 5.11.

Each primer set positively identified all of the *Trichoderma aggressivum* isolates in the reference group except for isolate FM 11, which was only amplified by the primer set 41+180. Novel primers gave faster reactivity than those of Chen *et al.* (1999a), possibly because the copy number of the *tef1* gene is higher in *T. aggressivum* than the arbitrary sequence targeted with these primers.

Primers ThF+ThR were the most selective and displayed no reactivity with any non-aggressive isolates. Primers 41+180 showed additional reactivity with two *Trichoderma harzianum* isolates and two *Trichoderma* sp. isolates, although reactivity with isolate 433 was weak. Primers 43+199 were strongly reactive with one *Trichoderma atroviride* isolate tested and weakly reactive with one *T. harzianum* and one *Trichoderma* sp. isolate. Of the novel primers set 44+199 gave results most similar to those of Chen *et al.* (1999a). These primers were reactive with the same isolates as primers ThF+ThR but also showed a very low level of reactivity with one *T. harzianum* isolate.

Tab. 5.3: Validation of novel and existing primers for identification of *T. aggressivum* isolates using real-time PCR.

Isolate*	Cycle crossing point (Cp)			
	41+180	43+199	44+199	ThF+ThR
100526	19.31	18.67	18.58	24.26
	19.20	18.88	18.59	24.29
FM 2	19.79	27.48	29.08	30.00
	19.60	27.33	29.43	30.00
FM 5	30.00	30.00	30.00	30.00
	30.00	30.00	30.00	30.00
FM 11	19.20	30.00	30.00	30.00
	19.15	30.00	30.00	30.00
FM 18	20.51	20.33	19.87	24.31
	20.63	20.18	20.28	25.20
K363	30.00	30.00	30.00	30.00
	30.00	30.00	30.00	30.00
K387	18.83	19.17	19.16	23.70
	20.18	19.04	19.00	25.20
K417	20.47	19.77	19.69	23.12
	20.67	19.85	19.69	23.87
K516	30.00	30.00	30.00	30.00
	30.00	30.00	30.00	30.00
K517	30.00	30.00	30.00	30.00
	30.00	30.00	30.00	30.00
T. atro	30.00	19.77	30.00	30.00
	30.00	19.85	30.00	30.00
355	30.00	30.00	30.00	30.00
	30.00	30.00	30.00	30.00
413	21.05	28.03	30.00	30.00
	21.26	28.25	30.00	30.00
433	27.13	30.00	30.00	30.00
	26.88	30.00	30.00	30.00
430	18.87	30.00	30.00	30.00
	17.86	30.00	30.00	30.00
Blank	30.00	30.00	30.00	30.00
	30.00	30.00	30.00	30.00

*Species listed in Table 2.1.

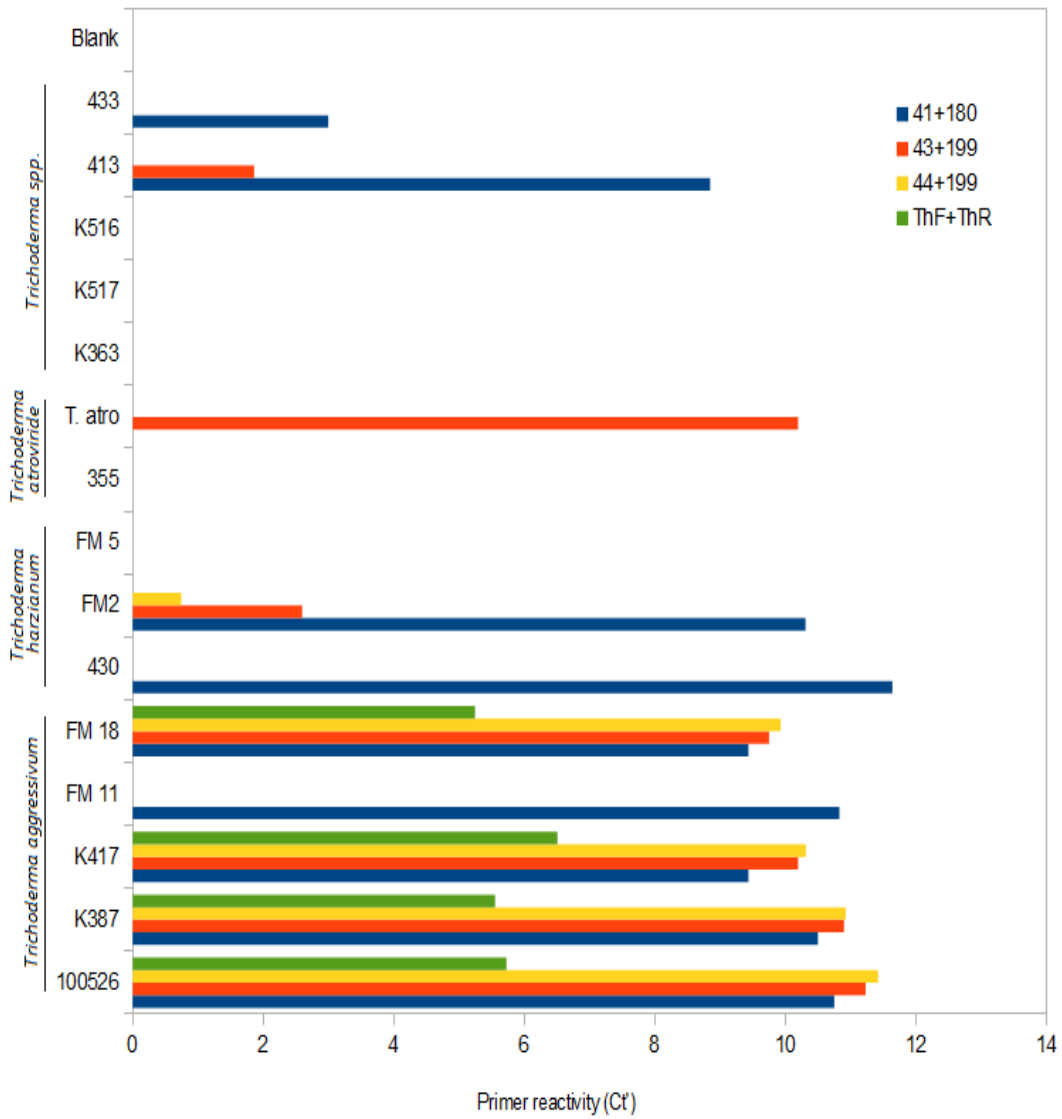

Fig. 5.11: Reactivity of novel and existing primers with *Trichoderma* isolates.

5.4 Differentiation of *Trichoderma* isolates using HPLC metabolite profiling

5.4.1 Optimisation of elution protocol

The initial HPLC elution protocol was based on a standard 30 minute cycle with an equilibration period using 5 % acetonitrile in the mobile phase followed by a linear gradient increasing from 5 % to 100 % acetonitrile with a hold step at 100 % to fully rinse the column and 10 minutes post run re-equilibration with 5 % acetonitrile. After running several *Trichoderma* extracts it was observed that there was a lag-phase after all the water soluble components were eluted followed by a large number of peaks with poor resolution between 5 and 10 minutes as the acetonitrile concentration increased from 20 % to 80 % (Figure 5.12). Few peaks were observed eluting at between 80 % and 100 % acetonitrile or during the ramp down period back to 5 % acetonitrile.

Gradients were modified for use with *Trichoderma* extracts by reducing the time between 5 % and 20 % to one minute. The gradient between 20 % and 80 % was prolonged to 19 minutes. The post run re-equilibration step was replaced with a 5 minute in-run re-equilibration step with detection on. Optimisation led to improved peak resolution in the busy areas of the chromatogram and the detection of more hydrophobic products in the latter stages of elution (Figure 5.13).

5.4.2 Metabolite profiles of *Trichoderma* isolates grown on different media

HPLC analysis was performed on plugs taken from *Trichoderma* isolates grown on MEA (Section 2.7.4, 2.7.5). Metabolite profiles of each isolate were compared to that of CBS 100526 as per Section 2.7.6, results are presented in Table 5.4 (Column A).

The correlation of the profiles of CBS 100526 and CBS 433.95 was good (0.96) but a high degree of correlation was observed with each other isolate tested. Other than isolate 355 (a *Trichoderma atroviride* isolate) every profile obtained from *Trichoderma* isolates grown on MEA showed a correlation co-efficient of 0.9 or greater with that of CBS 100526.

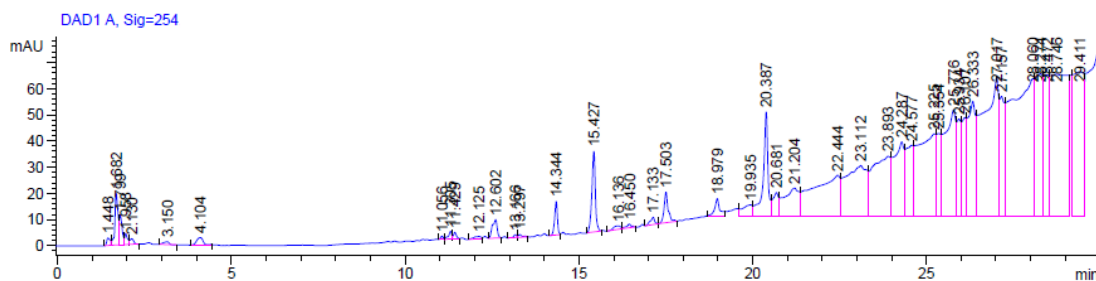

Tab. 5.4: Cophenetic correlation of metabolite profiles from *Trichoderma* isolates.

Strain	Classification	Correlation		
		A	B	C
100526	<i>Trichoderma aggressivum</i>	-	-	0.98
433.95	<i>Trichoderma aggressivum</i>	0.97	0.94	0.97
FM18	<i>Trichoderma aggressivum</i>	0.97	0.93	0.92
K387	<i>Trichoderma aggressivum</i>	0.96	0.92	0.93
FM2	<i>Trichoderma harzianum</i>	0.95	0.85	0.69
FM5	<i>Trichoderma harzianum</i>	0.98	0.88	0.84
430	<i>Trichoderma harzianum</i>	0.94	0.90	0.91
355	<i>Trichoderma atroviride</i>	0.88	0.68	0.66
K363	<i>Trichoderma sp</i>	0.97	0.72	0.73
K516	<i>Trichoderma sp</i>	0.97	0.90	0.84
K517	<i>Trichoderma sp</i>	0.97	0.89	0.84

A - Correlation of metabolite profile of isolates grown on MEA with CBS 100526 metabolite profile. B - Correlation of metabolite profile of isolates grown on TMM with CBS 100526 metabolite profile. C - Correlation of metabolite profile of isolates grown on TMM with composite profile of CBS 100526 and CBS 433.95.

5.4.3 Comparison of *Trichoderma* metabolite profiles to a *Trichoderma aggressivum* reference profile

A reference chromatogram for *Trichoderma aggressivum* was prepared by combining the profiles of CBS 100526 and CBS 433.95 grown in TMM using COWtool software. This profile was then compared with that of other *Trichoderma* isolates as a means of determining their similarity to *T. aggressivum*. Results are presented in Table 5.4 (Column C).

This method gave the best resolution of isolates. The similarity of each *Trichoderma* isolate other than *Trichoderma harzianum* 430 dropped below 0.90. The correlation of metabolite profiles of *T. aggressivum* with the reference chromatogram was in the range 0.92-0.98.

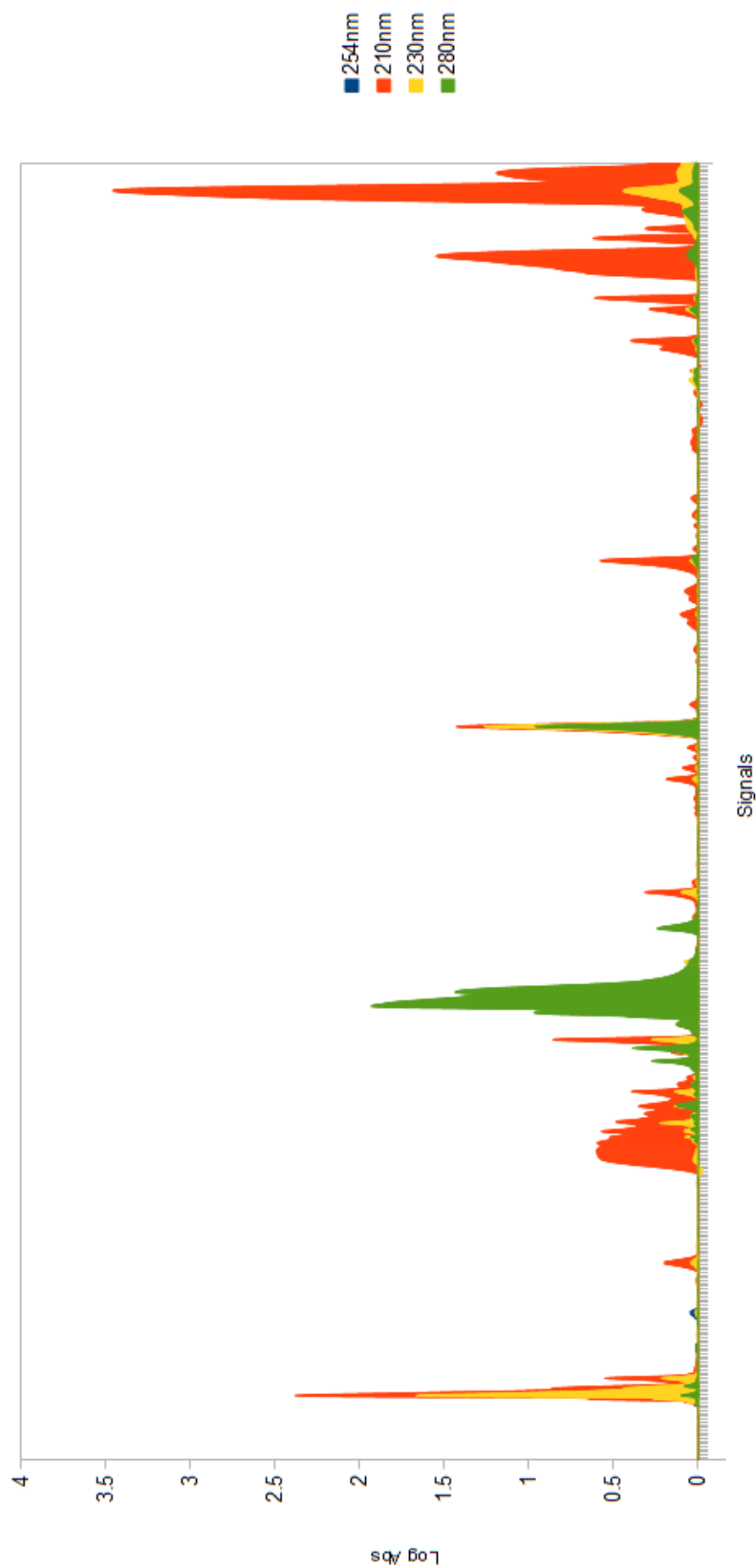

Fig. 5.14: Reference metabolite profile for *Trichoderma aggressivum*.

5.5 Discussion

5.5.1 DNA extraction methods

Species specific PCR amplification is the current standard method for the identification of *Trichoderma aggressivum*. Accurate PCR identification depends on effective DNA extraction methods and selective primers.

In this study methods for the isolation and purification of *T. aggressivum* DNA from a variety of sample types were assessed. For cultured *T. aggressivum* mycelium DNA extraction is relatively simple and several methods proved satisfactory. Of the methods which yielded good quality DNA from mycelial samples the Promega Wizard Magnetic DNA extraction kit was the least, while the ZR fungal/bacterial extraction kit provided highest concentration of DNA. Either of these methods is ideally suited for the purification of DNA from *Trichoderma* cultures to test by PCR.

Obtaining DNA from *T. aggressivum* spores and colonised mushroom substrate proved to be more difficult. Most of the methods tested relied on mechanical disruption with liquid nitrogen for complete cell lysis, this is not possible with liquid spore suspensions. Two methods were tested which used chemical lysis but neither produced quantifiable amounts of DNA from *T. aggressivum* spore. This may be because the conidia were too resilient to chemical lysis or the amount of DNA released from spores was too low to yield a useful concentration after extraction.

None of the DNA extraction methods tested proved suitable for the extraction of DNA from Bulk Phase III mushroom substrate. Obtaining PCR quality DNA from Bulk Phase III mushroom substrate poses several unique problems. In mushroom substrate *T. aggressivum* may be present in low abundance or as spores which are difficult to lyse. The fibrous nature of mushroom substrate creates difficulties with several common methods of mechanical disruption, and may trap DNA, reducing yields. During lysis the substrate tends to remain particulate, which interferes with filtration and centrifugation steps. The final barrier to the extraction of PCR amplifiable DNA from mushroom substrate is the presence of PCR inhibitors, such as humic acid.

Humic acids are breakdown product of organic matter, produced by Maillard

reaction (Jokic *et al.*, 2001). Due to their chemical similarity and binding affinity for each-other DNA and humic acids are co-purified by most DNA extraction methods (Crecchio & Stotzky, 1998; Allard, 2006). The presence of humic acids in a DNA sample prevent accurate quantification by spectrometry (Zipper, 2003) and may cause DNA degradation (Alaeddini, 2012). They are potent inhibitors of PCR and many other DNA manipulation procedures, concentrations as low as 8 pg/ μ l can prevent PCR (Tebbe & Vahjen, 1993). Humic acid contamination is a common problem in soil molecular biology (Ma & Michailides, 2007). Organic composts contain a significantly higher amount of humic substances than most soils (Howeler *et al.*, 2003), spent mushroom substrate can contain humic acid concentrations accounting for up to 35 % of all organic carbon (Paredes & Medina, 2009) as well as a high level of phenolic substances (Iiyama *et al.*, 1994), which also interfere with PCR (Ma & Michailides, 2007).

An effective extraction method for the purification of PCR amplifiable DNA from Bulk Phase III mushroom substrate is desirable for the direct quantification of *T. aggressivum* by PCR, but at present none has been published. There are several complicating factors unique to this type of extraction and a successful DNA extraction method must eliminate all of them, without over-manipulating or diluting the DNA to the extent that it becomes unusable. A reasonably short sample preparation time would also be advantageous, so that large sample sets can be analysed. There are several commercially available kits for the purification of DNA from soil, stool samples, and other humic acid rich sources and several published methods make use of these kits for the extraction of DNA from soil (Filion *et al.*, 2003; Hagn *et al.*, 2007) and compost (Reuter *et al.*, 2009) but without any information on their use with mushroom substrate it is difficult to assess how they would perform. Chemical and physical variation between different soil types and green compost is commonly enough to warrant adjustment of DNA extraction procedures, and mushroom substrate is considerably different from either.

There are several published methods for the extraction of DNA from compost and soil which make use of two stage extractions to purify DNA and eliminate PCR inhibitors separately. Such techniques as pre-lysis washing (He *et al.*, 2005; Hagn *et al.*, 2007), cell separation by differential centrifugation (Ma &

Michailides, 2007), agarose gel electrophoresis (LaMontagne *et al.*, 2002) and repeated purification steps in C-TAB (Blanc *et al.*, 1999) or chloroform-isoamyl alcohol (Howeler *et al.*, 2003), which may be useful in the extraction of DNA from mushroom substrate.

5.5.2 Identification of *Trichoderma aggressivum* by real-time PCR

A method for the identification of *Trichoderma aggressivum* with real-time PCR was developed. Real-time PCR has several advantages over end-point PCR such as speed, sensitivity, reduced risk of cross-contamination, high through-put, and quantitation (Klein, 2002). In real-time PCR analysis the point at which the fluorescence of the amplicon crosses the noise baseline (C_p) is calculated, this gives an indication of the copy number of the target DNA present which can be used to directly estimate the biomass of the organism from which the DNA was amplified (López-Mondéjar *et al.*, 2010).

The use of PCR with species specific primers is the most common method for the identification of *T. aggressivum*. There is no published information on the use of real-time PCR for this procedure. Primers used for real-time must meet certain criteria which are not necessary for standard PCR. Real-time PCR primers are recommended to have a GC content of 40-60 %, amplicon length of 100-200 bp and annealing temperatures for forward and reverse primers which are within 1 °C. Existing species selective primers for *T. aggressivum* did not meet all of these criteria so novel primers were designed.

To select a suitable target gene for primer design all available sequence information for *T. aggressivum* in GenBank was surveyed. Based on a BLAST similarity search the *tef1* gene was determined to be the least conserved among closely related *Trichoderma* species and therefore the most suitable target for selective primers. Due to the 99 % sequence similarity between the *tef1* gene in *T. aggressivum* f. *europaeum* and *T. aggressivum* f. *aggressivum* it was not possible to create primers which would differentiate the two subspecies. At present both subspecies are geographically isolated and so subspecies can be assigned presumptively, based on origin, but for future epidemiological studies it may be desirable to develop subspecies selective primers, to assess whether there is any overlap between the two populations.

Novel and existing primers displayed good reaction efficiency when used in real-time PCR with serially diluted *T. aggressivum* DNA. Two of the novel primer sets displayed efficiencies above the theoretical maximum, but melt curve analysis showed no non-specific binding. Reaction efficiencies above 2.0 may be observed if primer dimer artifacts are formed in later reaction cycles when the DNA template concentration is low relative to the primer concentration.

Melt curve analysis of the existing primers which target the ITS region showed irregular amplicon melting temperatures. This was attributed to the ~800 bp size of the PCR product generated by these primers. Long PCR products are more likely to contain motifs with different GC contents, resulting in multi-step DNA strand separation which does not follow predictable reaction kinetics. Without a reproducible melting curve it is difficult to assess whether the correct target sequence has been amplified from the real-time PCR data. As a result primer set 18S Int+ThI Int rev were determined to be unsuitable for use in real-time PCR.

The melting profile obtained from PCR amplification with the primers of Chen *et al.* (1999a) deviated from the ideal, again because of the size of the PCR product, but not to the extent that it could easily be mistaken for non-specific binding. These primers were used as a reference to determine the specificity of novel primers by testing them against a panel of aggressive and non-aggressive *Trichoderma* isolates. Melt curve analysis using novel selective primers showed no irregularities.

DNA was extracted from 15 *Trichoderma* isolates which had already been identified based on morphology and/or PCR, each of them having been isolated from mushroom growing facilities. Each *T. aggressivum* isolate tested except FM 11 showed reactivity with all of the selective primers. The reason for lack of reactivity with FM 11 is unclear.

The Novel primers showed considerably faster reactivity than those of Chen *et al.* (1999a), which is advantageous for detection of low level of *T. aggressivum* DNA. However the primer set ThF+ThR was the most selective as they showed no reactivity with any non-*T. aggressivum* *Trichoderma* isolates. The novel primer sets 41+180 and 43+199 showed reactivity with 2 and 3 non-aggressive *Trichoderma* isolates, respectively. Primer set 44+199 showed a very low level of reactivity with one *Trichoderma harzianum* isolate, but with further optimisation

these primers may prove to be as selective as the published primers.

Real-time PCR quantitation adds an extra dimension to the identification of *T. aggressivum* by PCR because it allows for simultaneous species assignment and quantification. In the future this method may allow for more rapid screening of mushroom farms and substrates for *T. aggressivum* contamination by eliminating the requirement for a two step quantification and identification process. This could be implemented in conjunction with cultural methods to quantify the amount of *T. aggressivum* growing in a mixed culture of fungi or, with the proper DNA extraction method and sampling regime, the direct quantification of *T. aggressivum* in mushroom substrate.

5.5.3 HPLC metabolite profiling

HPLC profiling of secondary metabolites was assessed as a means for differentiating *Trichoderma aggressivum* isolates from non-aggressive *Trichoderma* isolates. Optimisation of HPLC elution gradients allowed for better separation of *Trichoderma* metabolites, which showed a conserved pattern of elution with regards to time and acetonitrile concentration.

The degree of difference between metabolite profiles was shown to be dependant on the growth medium used. *Trichoderma* isolates grown on malt extract agar had highly similar metabolite profiles. More diverse profiles were observed when isolates were grown on a synthetic, defined medium.

A reference chromatogram was produced for *T. aggressivum* by combining chromatograms of two reference isolates. By comparing profiles of other *Trichoderma* isolates to this reference chromatogram it was possible to distinguish *T. aggressivum* isolates from non-aggressive isolates. The exact level of correlation between profiles required for positive species identification cannot be accurately defined, as it is impossible to estimate intraspecies variation in the production of secondary metabolites (Thrane *et al.*, 2001). However, a correlation of 0.92-0.98 was observed between the reference chromatogram and that obtained from two other *T. aggressivum* isolates while the profiles of all other *Trichoderma* isolates tested was in the 0.66-0.91 range, with highest correlation being observed for a *Trichoderma harzianum* isolate.

This technique offers a new method for the identification and characterisa-

tion of *T. aggressivum*. Metabolite profiling may be a more practical method for species identification than PCR because it differentiates species based on expressed phenotypes, rather than molecular sequence. The identification of metabolites unique to *T. aggressivum* could allow for highly effective species identification and provide information on the unique traits which make *T. aggressivum* a much more serious problem in the mushroom industry than other *Trichoderma* species.

6. GENERAL DISCUSSION

The fungus *Trichoderma aggressivum* is an economically significant pathogen of the cultivated mushroom *Agaricus bisporus* (Samuels *et al.*, 2002). It was first described in 1987 as a novel *Trichoderma harzianum* biotype (Seaby, 1987). Unlike other *Trichoderma* which are sometimes found growing in mushroom substrate this new variety caused massive crop losses and an epidemic affecting *A. bisporus* cultivation worldwide (Kredics *et al.*, 2010). Subsequent molecular analyses showed *T. aggressivum* to be a separate species from *T. harzianum* with two subspecies *Trichoderma aggressivum* f. *aggressivum* and *Trichoderma aggressivum* f. *europaeum*, responsible for the green mould outbreaks in North America and Europe, respectively (Muthumeenakshi *et al.*, 1994; Castle *et al.*, 1998; Chen *et al.*, 1999a,b; Samuels *et al.*, 2002). Technological advances in mushroom cultivation, particularly the introduction of the Bulk Phase III system reduced the incidence of *T. aggressivum* in Europe, but in the last decade reports of *T. aggressivum* infection of Bulk Phase III mushroom substrate began to surface (Lemmers, 2010). This raised questions about how well we understand the epidemiology of *T. aggressivum* and its interaction with *A. bisporus*, as well as prompting renewed interest in methods for detection of the fungus and to differentiate it from related, non-aggressive species.

While there has been research into the activities of *T. aggressivum* toward *A. bisporus* the exact mechanisms by which it reduces mushroom yields are poorly understood. Secreted metabolites from *T. aggressivum* have been shown to suppress the growth of *A. bisporus in vitro*, but to a lesser extent than other, non-aggressive species (Mumpuni *et al.*, 1998). The ability of *T. aggressivum* to colonise mushroom substrate and resist inhibition by substrate microflora better than other *Trichoderma* species has been linked to its virulence (Largeau *et al.*, 2000b; Savoie *et al.*, 2001b), but *T. aggressivum* grows better in ster-

ilised substrate, and there are conflicting reports on how necessary *A. bisporus* is to substrate colonisation by *T. aggressivum* (Largeteau *et al.*, 2000b; Mumpuni *et al.*, 1998). *T. aggressivum* has been shown to produce compounds harmful to *A. bisporus* *in vitro* and *in vivo*, including cell wall degrading enzymes (Mumpuni *et al.*, 1998; Krupke *et al.*, 2003; Williams *et al.*, 2003a; Guthrie & Castle, 2006) but coiling of *T. aggressivum* hyphae around those of *A. bisporus* is not frequently observed (Williams *et al.*, 2003a) so it is not clear whether *T. aggressivum* parasitises *A. bisporus* mycelium or impedes its growth through antibiosis and competition for nutrients.

In the first part of this work a proteomic analysis of *T. aggressivum* was performed. By studying the proteins of *T. aggressivum* we can obtain information about its biochemistry and lifestyle (Kim *et al.*, 2007). By using comparative proteomics it is possible to measure the change in expression of proteins in relation to stimuli and thereby identify proteins which are important to the response of *T. aggressivum* to those stimuli. Comparative proteomics has been used previously to study the interaction of *Trichoderma* species with plants and plant-pathogenic fungi (Sanz *et al.*, 2005; Marra *et al.*, 2006; da Silva Aires *et al.*, 2012) and has been used to study the relationship of *T. aggressivum* with *A. bisporus* (Williams *et al.*, 2003a; Guthrie & Castle, 2006).

In this study *T. aggressivum* was grown in the presence of mushroom substrate and *A. bisporus* cap tissue and proteins changing in expression were identified. None of the upregulated proteins observed were enzymes that might be involved the degradation of fungal cell walls such as laminarase or chitinase, which would indicate a mycoparasitic or antagonistic response. However as these proteins are secreted from the cell *in vivo* it is possible that they were not observed because this study focused on the cellular proteome, rather than the secretome. A stress response was observed in *T. aggressivum* induced by both treatments, but more strongly by the mushroom substrate treatment.

There was an upregulation in the expression of superoxide dismutase, which is an enzyme that detoxifies superoxide and one of the key components of the oxidative stress response (Bai *et al.*, 2001). There was also a change in the expression of spermidine synthase and ribosomal protein P60, both of which are indirectly involved in the oxidative stress response (Abramczyk *et al.*, 2003;

Maniratanachote *et al.*, 2006; Chattopadhyay *et al.*, 2009). The production of superoxide and other reactive oxygen species is a common method by which micro-organisms inhibit the growth of competitors and defend themselves against pathogens (Silar, 2005). The oxidative stress response of *T. aggressivum* may have a role in its ability to resist growth inhibition by mushroom substrate micro-flora and *A. bisporus*.

Expression of the protein guanylate kinase by *T. aggressivum* was upregulated in the mushroom tissue treatment and down-regulated in the presence of mushroom substrate. This protein is involved in DNA synthesis and cell signalling (Berger *et al.*, 1989; Robson *et al.*, 1991; Blaszczyk *et al.*, 2001; Li *et al.*, 2010), its differential expression may be related to the enhanced growth of *T. aggressivum* in the presence of *A. bisporus* and the inhibition of the growth of *T. aggressivum* caused by substrate micro-flora.

For several of the proteins analysed in this study homologs were not found in on-line databases. A number of these proteins were present in high abundance and were analysed repeatedly but still returned no match. This raises the question of whether the lack of a homolog was due to technical limitations or whether these proteins may not have a homolog in the databases searched. In the future *de novo* sequencing of these proteins might yield further insight into the unique characteristics of *T. aggressivum* which make it more harmful to mushroom cultivation than other *Trichoderma* species. Other research carrying on from this work could look at the protein expression of non-aggressive *Trichoderma* species under the same conditions to see if they behave differently from *T. aggressivum*, repeat of the differential expression experiment using live *A. bisporus* and mushroom substrate to stimulate *T. aggressivum* and, in light of the observed importance of the oxidative stress response of *T. aggressivum* analysis of the activities of enzymes relating to oxidative stress in *T. aggressivum* under different conditions and in strains exhibiting varying degrees of aggressive behaviour.

Chapter 4 of this work assessed the epidemiology of *T. aggressivum* in Bulk Phase III mushroom systems. In these systems substrate is spawn-run in bulk under strict hygiene and environmental controls to produce a high quality substrate, free from disease. Fully spawn-run mushroom substrate is known to be relatively resistant to colonisation by *T. aggressivum* (Fletcher, 1997; Rinker & Alm, 2000),

however, this information pertains to *in situ* spawn-run systems, where the substrate is not bulk handled after spawn-run. This raised the question of how the bulk handling performed after spawn-run in Bulk Phase III system might affect the susceptibility of mushroom substrate to infection by *T. aggressivum*.

In this study *T. aggressivum* colonised Phase III substrate was produced by infecting Phase II substrate with a *T. aggressivum* strain at spawning. This infected substrate was then used to inoculate healthy Phase III at the bulk handling stage at different infection levels. A secondary objectives assessed the effect of a compost supplement added at bulk handling on *T. aggressivum* infection.

It was shown that inoculation with infected substrate at bulk handling resulted in a significant reduction in mushroom yield in a dose dependant manner. No significant difference was observed in the yield loss between the supplemented and unsupplemented treatments, suggesting that the supplement used did not affected the growth of *T. aggressivum* when applied in this manner.

The experiment was repeated with more mixing at the bulk handling stage to simulate a higher level of mixing during tunnel emptying and transport, as well as to facilitate the removal of sub-samples for colony counting. In the repeated experiment the impact of *T. aggressivum* on the crop was considerably more severe. The level of *T. aggressivum* infection in the inoculum used for this experiment was found to be higher, but the relative reduction in yields seemed disproportionately high. It was hypothesised that the higher level of mixing exacerbated the effect of *T. aggressivum* on the crop, and a third experiment was designed to test this hypothesis.

In the third experiment supplement was not considered, as supplementation had not significantly affected the result in either previous experiment. Instead the two treatment were heavy and light mixing, to allow a direct comparison of the two mixing levels in a single experiment. Yield losses in the heavy mix treatment were significantly higher than for the light mix treatment, confirming that the level of mixing does affect crop loss caused by *T. aggressivum*. A significant interaction was observed between the effects of the mixing treatment and the infection level on crop yield. The yield loss caused by increasing infection level was exacerbated by a mixing.

During these cropping experiments methods for the detection and enumer-

ation of *T. aggressivum* in Bulk Phase III mushroom substrate were assessed. Quantitative PCR (qPCR) (Lane, 2010), weed mould analysis (WMA) (Kaufman *et al.*, 1963), most probable number analysis (MPN) (Halvorson & Ziegler, 1933; Briones *et al.*, 1999) and a direct plating assay (DPA) were compared. There was an increasing trend in the variability of results obtained from each method other than qPCR with decreasing infection levels. The qPCR method is more technically advanced than the others and made use of a larger sample size, which may account for its greater precision at low infection levels. The two microbiological counting methods gave comparable results, but the WMA method was more time-consuming, so the MPN method was deemed superior. DPA proved to be a simple method for the detection of *T. aggressivum* with a good level of sensitivity, but it is semi-quantitative, so only gives a rough indication of the level of infection.

With each method the experimental results were correlated with infection level, but they differed from the values expected based on the dilution levels used. It was observed that some transfer of *T. aggressivum* occurred between infected substrate and uninfected, but that this did not result in an even distribution of *T. aggressivum* particles throughout the substrate. The heterogeneous distribution of *T. aggressivum* in mushroom substrate makes obtaining a representative sample difficult, particularly at low infection, which is something that must be taken into consideration when sampling Bulk Phase III substrate in industry.

Future work following from this study could assess a wider range of supplements for their effect on *T. aggressivum*. The biochemical characteristics of Bulk Phase III substrate before and after bulk handling could be studied to determine what factors influence susceptibility to *T. aggressivum* infection at this point. Repeat experiments using different methods of inoculation at bulk handling could be performed, it is unknown whether spores or hyphae are more important for infection of substrate at this point, or whether other factors associated with infected substrate might also be important. With regards to detection methods, industrial scale experiments could be used to develop an effective sampling system that addresses the level of heterogeneity in Bulk Phase III mushroom substrates.

In the final section of this study molecular and chemical methods for the detection and identification of *T. aggressivum* were studied. DNA extraction

methods were compared for their efficacy at purifying PCR quality DNA from *T. aggressivum* spores, mycelium and infected substrate. No method proved suitable for extraction from substrate due to complicating factors such as the co-purification of PCR inhibitors, but a number of methods produced high integrity, good quality DNA from *T. aggressivum* cultures. *T. aggressivum* selective primers were assessed for their suitability for use in real-time PCR. Existing selective primers produced amplicons larger than recommended for real-time PCR so novel selective primers were designed. It was not possible to design a primer set which distinguished between subspecies of *T. aggressivum* but a set was developed which identified *T. aggressivum* with a similar degree of accuracy to existing primers and better characteristics for real-time PCR. Future work on molecular identification of *T. aggressivum* could survey a larger range of *Trichoderma* isolates for reactivity with these primers, assess primer modifications for improving specificity and attempt to identify genes which are less conserved between *Trichoderma* species to develop more selective primers and possibly discriminate between *T. aggressivum* subspecies.

In the second part of Chapter 5 HPLC profiling of secondary metabolites was assessed as an alternative method for differentiating *Trichoderma* isolates. This method has been used to describe *Trichoderma* species previously, with results similar to those obtained by comparative sequence analysis (Thrane *et al.*, 2001; Kang *et al.*, 2011). Chromatographic profiles were found to be medium dependent, with more similar profiles being produced by isolates grown on MEA than on a synthetic minimal medium. A reference chromatogram was constructed using the profiles of two *T. aggressivum* reference isolates and comparison with this profile gave the best separation of aggressive and non-aggressive isolates. Future work in this area could include a wider range of *Trichoderma* species to estimate the overall variability in profile between species and set a similarity threshold for identification of *T. aggressivum*. Different media could be used to induce production of different secondary metabolites, similarly to the differential expression of proteins in Chapter 3, and thereby identify metabolites which may be associated with the growth of *T. aggressivum* in association with *A. bisporus*. Isolation and identification of chromatographic peaks unique to *T. aggressivum* could give further insight into the aggressive nature of the species and potentially lead to the

development of new diagnostic measures for the detection of *T. aggressivum* *in vivo*.

In conclusion, the work described in this thesis has shown:

- The activity of the proteomic stress response of *Trichoderma aggressivum* in response to *Agaricus bisporus* and mushroom substrate.
- That *T. aggressivum* infected mushroom substrate can spread infection to healthy Bulk Phase III substrate during bulk handling.
- That a higher level of mixing during bulk handling increases the severity of a *T. aggressivum* infection.
- A new real-time PCR method for the identification of *T. aggressivum*.
- The potential for use of HPLC metabolite profiling to identify *T. aggressivum* isolates.

BIBLIOGRAPHY

- Abercrombie, J. 1779. *The garden mushroom: its nature and cultivation. A treatise, exhibiting full and plain directions, for producing this desirable plant in Perfection and Plenty, according to the true successful Practice of the London Gardeners.*
- Able, A.J., Guest, D.I., & Sutherland, M.W. 1998. Use of a new tetrazolium-based assay to study the production of superoxide radicals by tobacco cell cultures challenged with avirulent zoospores of *Phytophthora parasitica* var *nicotianae*. *Plant Physiology*, **117**(2), 491–9.
- Abosriwil, S.O., & Clancy, K.J. 2004. A mini-bag technique for evaluation of fungicide effects on *Trichoderma* spp in mushroom compost. *Pest management science*, **60**(4), 350–8.
- Abramczyk, O., Zień, P., Zieliński, R., Pilecki, M., Hellman, U., & Szyszka, R. 2003. The protein kinase 60S is a free catalytic CK2 α subunit and forms an inactive complex with superoxide dismutase SOD1. *Biochemical and Biophysical Research Communications*, **307**(1), 31–40.
- Adams, J.D.W., & Frostick, L.E. 2008. Investigating microbial activities in compost using mushroom *Agaricus bisporus* cultivation as an experimental system. *Bioresource technology*, **99**(5), 1097–102.
- Addinall, S.G., Downey, M., Yu, M., Zubko, M.K., Dewar, J., Leake, A., Hallinan, J., Shaw, O., James, K., Wilkinson, D.J., Wipat, A., Durocher, D., & Lydall, D. 2008. A genomewide suppressor and enhancer analysis of *cdc13-1* reveals varied cellular processes influencing telomere capping in *Saccharomyces cerevisiae*. *Genetics*, **180**(4), 2251–66.

- Ahlawat, O.P., & Singh, R. 2009. Influence of pH , temperature and cultural media on decolorization of synthetic dyes through spent substrate of different mushrooms. *Journal of Scientific and Industrial Research*, **68**(December), 1068–1074.
- Alaeddini, R. 2012. Forensic implications of PCR inhibition—A review. *Forensic science international. Genetics*, **6**(3), 297–305.
- Aljanabi, S.M., & Martinez, I. 1997. Universal and rapid salt-extraction of high quality genomic DNA for PCR-based techniques. *Nucleic Acids Research*, **25**(22), 4692–4693.
- Allard, B. 2006. A comparative study on the chemical composition of humic acids from forest soil, agricultural soil and lignite deposit. *Geoderma*, **130**(1-2), 77–96.
- Anastasi, A., Varese, G. Cristina, & Marchisio, V.P. 2005. Isolation and identification of fungal communities in compost and vermicompost. *Mycologia*, **97**(1), 33–44.
- Anderson, M.G., Beyer, D.M., & Wuest, P.J. 2000. Using spawn strain resistance to manage *Trichoderma* gree mold. *Pages 641–643 of: Mushroom Science XV: Science and Cultivation of Edible Fungi*.
- Arevalo-Pinzon, G., Curtidor, H., Reyes, C., Pinto, M., Vizcaíno, C., Patarroyo, M., & Patarroyo, M.E. 2010. Fine mapping of *Plasmodium falciparum* ribosomal phosphoprotein PfP0 revealed sequences with highly specific binding activity to human red blood cells. *Journal of Molecular Medicine (Berlin, Germany)*, **88**(1), 61–74.
- Ayala, M., Vázquez, C., Meneses, M., Loera, O., & Mendoza, G.D. 2011. Fibrolytic potential of spent compost of the mushroom *Agaricus bisporus* to degrade forages for ruminants. *Journal of Microbiology*, **5**(3), 241–249.
- Baars, J., Rutjens, J., & Roland, M. 2011. Can volatiles emitted by compost during spawn run be used to detect green mould infection early? *Proceed-*

- ings of the 7th international Conference on Mushroom Biology and Mushroom Products*, **1**.
- Baars, J., Rutjens, J., & Roland, M. 2012. Detection of *Trichoderma aggressivum* green mould during spawn-run. *Pages 343–349 of: Proceedings of the 18th international congress on mushroom biology an mushroom science: Mushroom Science XVIII*.
- Bai, Z., Harvey, L.M., & McNeil, B. 2001. Use of the chemiluminescent probe lucigenin to monitor the production of the superoxide anion radical in a recombinant *Aspergillus niger* (B1-D). *Biotechnology and Bioengineering*, **75**(2), 204–11.
- Barry, J., Grant, J., Doyle, O., & Grogan, H. 2008. Partial substitution of peat with spent mushroom substrate in peat-based casing blends. *Pages 288–309 of: Science and cultivation of edible and medicinal fungi: Mushroom Science XVII*.
- Berger, Albin, Schiltz, Emile, & Georg, E. 1989. Guanylate kinase from *Saccharomyces cerevisiae*. *European Journal of Biochemistry*, **184**, 433–444.
- Bergin, D., Reeves, E.P., Renwick, J., Frans, B., Kavanagh, K., & Wientjes, F.B. 2005. Superoxide production in *Galleria mellonella* hemocytes : identification of proteins homologous to the NADPH oxidase complex of human neutrophils. *Infection and Immunity*, **73**(7), 4161–4170.
- Beyer, D.M., Wuest, P.J., & Kremser, J.J. 2000. Evaluation of epidemiological factors and mushroom substrate characteristics influencing the occurrence and development of *Trichoderma* green mold. *Pages 633–640 of: Mushroom Science XV: Science and Cultivation of Edible Fungi*.
- Blanc, M., Marilley, L., Be, T., & Aragno, M. 1999. Thermophilic bacterial communities in hot composts as revealed by most probable number counts and molecular (16S rDNA) methods. *Microbial Ecology*, **28**, 141–149.

- Blaszczyk, J., Li, Y., Yan, H., & Ji, X. 2001. Crystal structure of unligated guanylate kinase from yeast reveals GMP-induced conformational changes. *Journal of Molecular Biology*, **307**, 247–257.
- Blaszczyk, L., Popiel, D., Chełkowski, J., Koczyk, G., Samuels, G.J., Sobieralski, K., & Siwulski, M. 2011. Species diversity of *Trichoderma* in Poland. *Journal of Applied Genetics*, **52**(2), 233–243.
- Briones, M., Aurelio, Jr., & Reichardt, Wolfgang. 1999. Estimating microbial population counts by most probable number using Microsoft Excel [®]. *Journal of Microbiological Methods*, **35**, 157–161.
- Callac, P., Spataro, C., Caille, A., & Imbernon, M. 2006. Evidence for outcrossing via the Buller phenomenon in a substrate simultaneously inoculated with spores and mycelium of *Agaricus bisporus*. *Applied and environmental microbiology*, **72**(4), 2366–2372.
- Carsolio, C., Benhamou, N., Haran, S., Cortés, C., Gutiérrez, A., Chet, I., & Corte, C. 1999. Role of the *Trichoderma harzianum* endochitinase gene, ech42, in Mycoparasitism. *Applied and Environmental Microbiology*, **65**(3), 9292–935.
- Castle, A., Speranzini, D., Rghei, N., Alm, G., Rinker, D., & Bissett, J. 1998. Morphological and molecular identification of *Trichoderma* isolates on North American mushroom farms. *Applied and environmental microbiology*, **64**(1), 133–7.
- Chattopadhyay, M.K., Tabor, C.W., & Tabor, H. 2003. Spermidine but not spermine is essential for hypusine biosynthesis and growth in *Saccharomyces cerevisiae*: spermine is converted to spermidine *in vivo* by the FMS1-amine oxidase. *Proceedings of the National Academy of Sciences of the United States of America*, **100**(24), 13869–13874.
- Chattopadhyay, M.K., Chen, W., Poy, G., Cam, M., Stiles, D., & Tabor, H. 2009. Microarray studies on the genes responsive to the addition of spermidine or spermine to a *Saccharomyces cerevisiae* spermidine synthase mutant. *Yeast*, **29**(August), 531–544.

-
- Chaverri, P., & Samuels, G.J. 2003. *Hypocrea/Trichoderma* (Ascomycota, Hypocreales, Hypocreaceae): species with green ascospores. *Studies in Mycology*, **48**, 116–152.
- Chaverri, P., Castlebury, L.A., Samuels, G.J., & Geiser, D.M. 2003. Multilocus phylogenetic structure within the *Trichoderma harzianum/Hypocrea lixii* complex. *Molecular Phylogenetics and Evolution*, **27**(2), 302–313.
- Chen, L., Xie, B., & Wach, M.P. 2008. A general review of the Chinese mushroom industry. *Pages 70–80 of: Science and cultivation of edible and medicinal fungi: Mushroom Science XVII*.
- Chen, X., Romaine, C.P., Ospina-Giraldo, M.D., & Royse, D.J. 1999a. A polymerase chain reaction-based test for the identification of *Trichoderma harzianum* biotypes 2 and 4, responsible for the worldwide green mold epidemic in cultivated *Agaricus bisporus*. *Applied Microbiology and Biotechnology*, **52**(2), 246–250.
- Chen, X., Romaine, C.P., Tan, Q., Schlaghaufer, B., Royse, D.J., & Huff, D.R. 1999b. PCR-Based genotyping of epidemic and preepidemic *Trichoderma* isolates associated with green mold of *Agaricus bisporus*. *Applied and Environmental Microbiology*, **65**(6), 2674–2678.
- Chiu, S.-W., Gao, T., Chan, C.S.-S., & Ho, C.K.-M. 2009. Removal of spilled petroleum in industrial soils by spent compost of mushroom *Pleurotus pulmonarius*. *Chemosphere*, **75**(6), 837–42.
- Condliffe, A.M., Kitchen, E., & Chilvers, E.R. 1998. Neutrophil priming: pathophysiological consequences. *Cellular & Molecular Biology (Oxford)*, **471**, 461–471.
- Cox, G.M., Harrison, T.S., Mcdade, H.C., Taborda, P., Heinrich, G., Casadevall, A., John, R., Taborda, C.P., & Perfect, J.R. 2003. Superoxide dismutase influences the virulence of *Cryptococcus neoformans* by affecting growth within macrophages. *Infection and Immunity*, **71**(1), 137–180.

- Crecchio, C., & Stotzky, G. 1998. Binding of DNA on humic acids: effect on transformation of *Bacillus subtilis* and resistance to DNase. *Science*, **30**(8), 1061–1067.
- Curach, N.C., Teò, V.S.J., Gibbs, M.D., Bergquist, P.L., & Nevalainen, K.M.H. 2004. Isolation, characterization and expression of the hex1 gene from *Trichoderma reesei*. *Gene*, **331**(Apr.), 133–40.
- da Silva Aires, R., Steindorff, A.S., Ramada, M.H.S., de Siqueira, S.J.L., & Ulhoa, C.J. 2012. Biochemical characterization of a 27kDa 1,3- β -d-glucanase from *Trichoderma asperellum* induced by cell wall of *Rhizoctonia solani*. *Carbohydrate Polymers*, **87**(2), 1219–1223.
- Danai, O., Cohen, H., Esov, N., Yehieli, N., & Levanon, D. 2011. Recycling spent mushroom substrate in avocado orchards. *In: Proceeding of the 7th International Conference on Mushroom Biology and Mushroom Products*, vol. 1.
- Danesh, Y.R., Goltapeh, E.R., & Rohani, H. 2000. Identification of *Trichoderma* species causing green mould in button mushroom farms, distribution and their relative abundance. *Pages 653–660 of: Mushroom Science XV: Science and Cultivation of Edible Fungi*.
- de la Fuente, M.E., Beyer, D.M., & Rinker, D.L. 1998. First report of *Trichoderma harzianum* biotype Th4 on commercial button mushrooms in California. *Plant Pathology*, **82**(12), 1404.
- den Ouden, M.C.M.B. 2012. Hygiene-Cultivating mushrooms without the use of chemical agents. *Pages 377–383 of: Proceedings of the 18th international congress on mushroom biology an mushroom science: Mushroom Science XVIII*.
- Diamantopoulou, P., & Philippoussis, A. 2001. Production attributes of *Agaricus bisporus* white and off-white strains and the effect of calcium chloride irrigation on productivity and quality. *Scientia Horticulturae*, **91**, 379–391.

-
- Dodd, S.L., Crownhurst, R.N., Rodrigo, A.G., Samuels, G.J., Hill, R.A., & Stewart, A. 2000. Examination of *Trichoderma* phylogenies derived from ribosomal DNA sequence data. *Mycological Research*, **104**(1), 23–34.
- Dodd, S.L., Lieckfeldt, E., & Samuels, G.J. 2003. *Hypocrea atroviridis* sp. nov., the teleomorph of *Trichoderma atroviride*. *Mycologia*, **95**(1), 27–40.
- Domig, K.J., Mayer, H.K., & Kneifel, W. 2003. Methods used for the isolation, enumeration, characterisation and identification of *Enterococcus* spp. *International Journal of Food Microbiology*, **88**(2-3), 165–188.
- Druzhinina, I., & Kubicek, C.P. 2005. Species concepts and biodiversity in *Trichoderma* and *Hypocrea*: from aggregate species to species clusters? *Journal of Zhejiang University Science*, **6**(2), 100–112.
- Druzhinina, I.S., Kopchinskiy, A.G., Komoj, M., Bissett, J., Szakacs, G., & Kubicek, C.P. 2005. An oligonucleotide barcode for species identification in *Trichoderma* and *Hypocrea*. *Fungal Genetics and Biology*, **42**, 813–828.
- Druzhinina, I.S., Seidl-Seiboth, V., Herrera-Estrella, A., Horwitz, B.A., Kenerley, C.M., Monte, E., Mukherjee, P.K., Zeilinger, S., Grigoriev, I.V., & Kubicek, C.P. 2011. *Trichoderma*: the genomics of opportunistic success. *Nature reviews. Microbiology*, **9**(10), 749–59.
- Durrant, J.A., Wood, D.A., & Cain, R.B. 1990. Lignocellulose biodegradation by *Agaricus bisporus* during solid substrate fermentation. *Journal of General Microbiology*, **137**, 751–755.
- Eckstein, H. 1988. Evidence for cyclic GMP in the yeast *Saccharomyces cerevisiae*, and studies on its possible role in growth. *Journal of Biosciences*, **13**(5-6), 386–396.
- Esbensen, K.H., & Heydorn, K. 2004. Metrology in sampling a first foray (biological materials). *Chemometrics and Intelligent Laboratory Systems*, **74**(1), 115–120.

-
- Filion, M., St-Arnaud, M., & Jabaji-Hare, S.H. 2003. Direct quantification of fungal DNA from soil substrate using real-time PCR. *Journal of microbiological methods*, **53**(1), 67–76.
- Fletcher, J.T. 1997. Mushroom spawn and the development of *Trichoderma harzianum* compost mold. *Mushroom News*, **45**(8), 6–8.
- Flores, C., Vidal, C., Trejo-Hernández, M.R., Galindo, E., & Serrano-Carreón, L. 2009. Selection of *Trichoderma* strains capable of increasing laccase production by *Pleurotus ostreatus* and *Agaricus bisporus* in dual cultures. *Journal of Applied Microbiology*, **106**(1), 249–57.
- Fordyce, C. 1970. Relative numbers of certain microbial groups present in compost used for mushroom (*Agaricus bisporus*) propagation. *Applied microbiology*, **20**(2), 196–9.
- Frampton, G., Moriya, S., Pearson, J.D., Isenberg, D.A., Ward, F.J., Smith, T.A., Panayiotou, A., Staines, N.A., & Murphy, J.J. 2000. Identification of candidate endothelial cell autoantigens in systemic lupus erythematosus using a molecular cloning strategy: a role for ribosomal P protein P0 as an endothelial cell autoantigen. *Rheumatology (Oxford, England)*, **39**(10), 1114–20.
- Friedl, M.A., & Druzhinina, I.S. 2012. Taxon-specific metagenomics of *Trichoderma* reveals a narrow community of opportunistic species that regulate each other's development. *Microbiology*, **158**(1), 69–83.
- Fries, E. 1825. *Systema Orbis Vegetabilis*.
- Fu, X.-Z., Chen, C.-W. and Wang, Y., Liu, J.-H., & Moriguchi, T. 2011. Ectopic expression of MdSPDS1 in sweet orange (*Citrus sinensis* Osbeck) reduces canker susceptibility: involvement of H₂O₂ production and transcriptional alteration. *BMC Plant Biology*, **11**(1), 55.
- Gams, W., & Meyer, W. 1998. What exactly is *Trichoderma harzianum*? *Mycologia*, **90**(5), 904.

- Garthright, W.E., & Blodgett, R.J. 2003. FDAs preferred MPN methods for standard, large or unusual tests, with a spreadsheet. *Food Microbiology*, **20**, 439–445.
- Giles, S.S., Batinic-haberle, I., Perfect, J.R., Cox, G.M., & Batinic, I. 2005. *Cryptococcus neoformans* mitochondrial superoxide dismutase : an essential link between antioxidant function and high-temperature growth. *Eukaryotic Cell*, **4**(1), 46–54.
- Goltapeh, E.N., & Danesh, Y.R. 2000. Studies on interaction between *Trichoderma* species and *Agaricus bisporus* mycelium. *Pages 661–666 of: Mushroom Science XV: Science and Cultivation of Edible Fungi*.
- Grogan, H.M., Noble, R., Gaze, R.H., & Fletcher, J.T. 1996. Control of *Trichoderma harzianum* - a weed mould of the cultivated mushroom. *Brighton Crop Protection - Pests & Diseases*, **4**(B-3), 337–343.
- Grogan, H.M., Scruby, A., & Harvey, L. 2000. Moulds in spawn-run compost and their effect on mushroom production. *Mushroom Science XV: Science and Cultivation of Edible Fungi*, **15**(2), 609–616.
- Grogan, H.M., O' Brien, M., Kavanagh, K., Dobrovin-Penington, A., Lane, C., & Noble, R. 2012. Epidemiology of *Trichoderma aggressivum* in Bulk Phase 3 compost for *Agaricus bisporus* production. *In: Proceedings of the 18th Congress of the International Society for Mushroom Biology and Mushroom Products*.
- Guillén, F., Martínez, M.J., Muñoz, C., & Martínez, A.T. 1997. Quinone redox cycling in the ligninolytic fungus *Pleurotus eryngii* leading to extracellular production of superoxide anion radical. *Archives of Biochemistry and Biophysics*, **339**(1), 190–9.
- Guthrie, J.L., & Castle, A.J. 2006. Chitinase production during interaction of *Trichoderma aggressivum* and *Agaricus bisporus*. *Canadian Journal of Microbiology*, **52**, 961–967.
- Gy, P. 2004a. *Chemometrics and Intelligent Laboratory Systems*, **74**(1), 7–24.

-
- Gy, P. 2004b. Sampling of discrete materials II. Quantitative approach-sampling zero-dimensional objects. *Chemometrics and Intelligent Laboratory Systems*, **74**(1), 25–38.
- Gy, P. 2004c. Sampling of discrete materials III. Quantitative approach-sampling one-dimensional objects. *Chemometrics and Intelligent Laboratory Systems*, **74**(1), 39–47.
- Györfi, J., & Geösel, A. 2008. Biological against *Trichoderma* species in *Agaricus* cultivation. *Pages 158–164 of: Proceedings of the 6th International Conference on Mushroom Biology and Mushroom products.*
- Hagiya, A., Naganuma, T., Maki, Y., Ohta, J., Tohkairin, Y., Shimizu, T., Nomura, T., Hachimori, A., & Uchiumi, T. 2005. A mode of assembly of P0, P1, and P2 proteins at the GTPase-associated center in animal ribosome: in vitro analyses with P0 truncation mutants. *The Journal of Biological Chemistry*, **280**(47), 391–393.
- Hagn, A., Wallisch, S., Radl, V., Charles Munch, J., & Schloter, M. 2007. A new cultivation independent approach to detect and monitor common *Trichoderma* species in soils. *Journal of Microbiological Methods*, **69**(1), 86–92.
- Halvorson, H.O., & Ziegler, N.R. 1933. Application of statistics to problems in bacteriology I. A means of determining bacterial population by the dilution method. *Journal of Bacteriology*, **25**(2), 101–121.
- Hammel, K.E., Kapich, A.N., Jr, Kenneth A.J., & Ryan, Z.C. 2002. Reactive oxygen species as agents of wood decay by fungi. *Enzyme and Microbial Technology*, **30**, 445–453.
- Harman, G.E., Howell, C.R., Viterbo, A., Chet, I., & Lorito, M. 2004. *Trichoderma* species—opportunistic, avirulent plant symbionts. *Nature reviews. Microbiology*, **2**(1), 43–56.
- Hatvani, L., Antal, Z., Manczinger, L., Szekeres, A., Druzhinina, I.S., Kubicek, C.P., Nagy, A., Nagy, E., Vágvölgyi, C., & Kredics, L. 2007. Green mold dis-

- eases of *Agaricus* and *Pleurotus* spp. are caused by related but phylogenetically different *Trichoderma* species. *Phytopathology*, **97**(4), 532–537.
- He, J., Xu, Z., & Hughes, J. 2005. Pre-lysis washing improves DNA extraction from a forest soil. *Soil Biology and Biochemistry*, **37**(12), 2337–2341.
- Herigstad, B., Hamilton, M., & Heersink, J. 2001. How to optimize the drop plate method for enumerating bacteria. *Journal of Microbiological Methods*, **44**(2), 121–9.
- Hermosa, M.R., Grondola, I., & Monte, E. 1999. Isolation of *Trichoderma harzianum* Th2 from commercial mushroom compost in Spain. *Plant Disease*, **83**(6), 591.
- Hernández, R.C.L., Largeteau, M., Farnet, A.-M. nad Minvielle, N., Regnault-Roger, C., & Savoie, J.-M. 2011. Phenotypic variability in cultivars and wild strains of *Agaricus brailiensis* and *Agaricus subrufescens*. *Pages 38–49 of: Proceedings of the 7th International Conference on Mushroom Biology and Mushroom Products*, vol. 2.
- Hibbett, D.S, Binder, M., Bischoff, J.F., Blackwell, M., Cannon, P.F., Eriksson, O.E., Huhndorf, S., James, T., Kirk, P.M., Lücking, R., Thorsten Lumbsch, H., Lutzoni, F., Matheny, P.B., McLaughlin, David J., Powell, M.J., Redhead, S., Schoch, C.L., Spatafora, J.W., Stalpers, J.A., Vilgalys, R., Aime, M.C., Aptroot, A., Bauer, R., Begerow, D., Benny, G.L., Castlebury, L.A., Crous, P.W., Dai, Y.-C., Gams, W., Geiser, D.M., Griffith, G.W., Gueidan, C., Hawksworth, D.L., Hestmark, G., Hosaka, K., Humber, R.A., Hyde, K.D., Ironside, J.E., Kõljalg, U., Kurtzman, C.P., Larsson, K.-H., Lichtwardt, R., Longcore, J., Miadlikowska, Jolanta, Miller, Andrew, Moncalvo, Jean-Marc, Mozley-Standridge, Sharon, Oberwinkler, Franz, Parmasto, E., Reeb, V., Rogers, J.D., Roux, C., Ryvarden, L., Sampaio, J. Paulo, Schüssler, A., Sugiyama, J., Thorn, R.G., Tibell, L., Untereiner, W.A., Walker, C., Wang, Z., Weir, A., Weiss, M., White, M.M., Winka, K., Yao, Y.-J., & Zhang, N. 2007. A higher-level phylogenetic classification of the Fungi. *Mycological Research*, **111**(Pt 5), 509–547.

- Howeler, M., Ghiorse, W.C., & Walker, L.P. 2003. A quantitative analysis of DNA extraction and purification from compost. *Journal of Microbiological Methods*, **54**, 37–45.
- Hwang, C.-S., Baek, Y.-U., Yim, H.-S., & Kang, S.-O. 2003. Protective roles of mitochondrial manganese-containing superoxide dismutase against various stresses in *Candida albicans*. *Yeast*, **20**(11), 929–941.
- Hwang, C.-S. and Rhie, G., Oh, J.-H., Huh, W.-K., Yim, H.-S., & Kang, S.-O. 2002. Copper- and zinc-containing superoxide dismutase (Cu/ZnSOD) is required for the protection of *Candida albicans* against oxidative stresses and the expression of its full virulence. *Microbiology (Reading, England)*, **148**(Pt 11), 3705–13.
- Idress, H.A., Suliman, S.A., Omar, K.S., El-Komy, H.M.A, & Sarwar, M. 2012. Occurrence and Microbiological Characteristics of *Trichoderma* in Al-Jabal Al-Akhdar Region, Libya. *Journal of Biological Sciences*, **12**, 209–217.
- Iiyama, K., Stone, B.A., & Macauley, B.J. 1994. Compositional changes in compost during composting and growth of *Agaricus bisporus*. *Applied and environmental microbiology*, **60**(5), 1538–46.
- Inbar, J., & Chet, I. 1995. The role of recognition in the induction of specific chitinases during mycoparasitism by *Trichoderma harzianum*. *Microbiology*, **141**(1), 2823–9.
- Jess, S., Murchie, A.K., & Bingham, J.F.W. 2007. Potential sources of sciarid and phorid infestations and implications for centralised phases I and II in mushroom compost production. *Crop protection*, **26**(4), 455–464.
- Johnson, L.F., Bernard, E.C., & Qian, P. 1987. Isolation of *Trichoderma* spp. at low temperatures from Tennessee and Alaska soils. *Plant Disease*, **71**(2), 137–140.
- Jokic, A., A., Frenkel, Vairavamurthy, M.A., & Huang, P.M. 2001. Birnessite analysis of the Maillard reactions: its significance in natural humification. *Geophysical research letters*, **28**(20), 2899–2902.

- Jordan, S.N., Mullen, G.J., & Murphy, M.C. 2008. Composition variability of spent mushroom compost in Ireland. *Bioresource technology*, **99**(2), 411–8.
- Kang, D., Kim, J, Choi, N.J., Kwang-Hyeon, L., & Lee, C.H. 2011. Chemotaxonomy of *Trichoderma* spp. using mass spectrometry-based metabolite profiling. *Journal of Microbiology and Biotechnology*, **21**(1), 5–13.
- Kaufman, D.D., Williams, L.E., & Sumner, C.B. 1963. Effect of plating medium and incubation temperature on growth of fungi in soil-dilution plates. *Canadian Journal of Microbiology*, **9**(6), 741–751.
- Keller, N.P., Turner, G., & Bennett, J.W. 2005. Fungal secondary metabolism - from biochemistry to genomics. *Nature reviews Microbiology*, **3**(12), 937–947.
- Kim, Y., Nandakumar, M.P., & Marten, M.R. 2007. Proteomics of filamentous fungi. *Trends in Biotechnology*, **25**(9), 395–400.
- Klein, D. 2002. Quantification using real-time PCR technology: applications and limitations. *Trends in Molecular Medicine*, **8**(6), 257–260.
- Klemsdal, S.S., Hayes, C.K., Hjeljord, L., Lorito, M., Harman, G.E., & Tronsmo, A. 1996. Isolation and characterization of a cDNA from *Trichoderma harzianum* P1 encoding a 14-3-3 protein homolog. *Gene*, **171**(1), 123–127.
- Komon-Zelazowska, M., Bissett, J., Zafari, D., Hatvani, L., Manczinger, L., Woo, S., Lorito, M., Kredics, L., Kubicek, C.P., & Druzhinina, I.S. 2007. Genetically closely related but phenotypically divergent *Trichoderma* species cause green mold disease in oyster mushroom farms worldwide. *Applied and Environmental Microbiology*, **73**(22), 7415–7426.
- Konrad, M. 1992. Cloning and expression of the essential gene for guanylate kinase from yeast. *The Journal of Biological Chemistry*, **267**(36), 25652–5.
- Kredics, L., Kocsubé, S., Nagy, L., Komo-Zelazowska, M., Manczinger, L., Sajben, E., Nagy, A., Vágvölgyi, C., Kubicek, C.P., Druzhinina, I.S., & Hatvani, L. 2009. Molecular identification of *Trichoderma* species associated with *Pleurotus ostreatus* and natural substrates of the oyster mushroom. *FEMS Microbiology Letters*, **300**(1), 58–67.

- Kredics, L., Jimenez, L.G., Naeimi, S., Czifra, D., Urbán, P., Manczinger, L., & Vágvölgyi, C. 2010. A challenge to mushroom growers : the green mould disease of cultivated champignons. *Pages 295–305 of: Current Research, Technology and Education topics in Applied Microbiology and Microbial Biotechnology.*
- Krupke, O.A.t, Castle, A.J., & Rinker, D.L. 2003. The North American mushroom competitor, *Trichoderma aggressivum f. aggressivum*, produces antifungal compounds in mushroom compost that inhibit mycelial growth of the commercial mushroom *Agaricus bisporus*. *Mycological Research*, **107**(12), 1467–1475.
- Kubicek, C.P., Herrera-Estrella, A., Seidl-Seiboth, V., Martinez, D.A., Druzhinina, I.S., Thon, M., Zeilinger, S., Casas-Flores, S., Horwitz, B.A., Mukherjee, P.K., Mukherjee, M., Kredics, L., Alcaraz, L.D., Aerts, A., Antal, Z., Atanasova, L., Cervantes-Badillo, M.G., Challacombe, J., Chertkov, O., McCluskey, K., Couplier, F., Deshpande, N., von Döhren, H., Ebbole, D.J., Esquivel-Naranjo, E.U., Fekete, E., Flipphi, M., Glaser, F., Gómez-Rodríguez, E.Y., Gruber, S., Han, C., Henrissat, B., Hermosa, R., Hernández-Oñate, M, Karaffa, L., Kosti, I., Le Crom, S., Lindquist, E., Lucas, S., Lübeck, M., Lübeck, P.S., Margeot, A., Metz, B., Misra, M., Nevalainen, H., Omann, M., Packer, N., Perrone, G., Uresti-Rivera, E.E., Salamov, A., Schmoll, M., Seiboth, B., Shapiro, H., Sukno, S., Tamayo-Ramos, J.A., Tisch, D., Wiest, A., Wilkinson, H.H., Zhang, M., Coutinho, P.M., Kenerley, C.M., Monte, E., Baker, S.E., & Grigoriev, I.V. 2011. Comparative genome sequence analysis underscores mycoparasitism as the ancestral life style of *Trichoderma*. *Genome Biology*, **12**(4), R40.
- Kullnig-Gradinger, C.M., Szakacs, G., & Kubicek, C.P. 2002. Phylogeny and evolution of the genus *Trichoderma* : a multigene approach. *Mycological Research*, **106**(7), 757–767.
- Kurbanoglu, E.B., Algur, O.F., & Zulkadir, A. 2004. Submerged production of edible mushroom *Agaricus bisporus* mycelium in ram horn hydrolysate. *Industrial Crops and Products*, **19**(3), 225–230.
- Kuznetsov, V.V., Radyukina, N.L., & Shevyakova, N.I. 2006. Polyamines and

- stress: Biological role, metabolism, and regulation. *Russian Journal of Plant Physiology*, **53**(5), 583–604.
- Lamb, C., & Dixon, R.A. 1997. The oxidative burst in plant disease resistance. *Annual Review of Plant Physiology and Plant Molecular Biology*, **48**(June), 251–275.
- LaMontagne, M.G., Michel, F.C., Holden, P.A., & Reddy, C.A. 2002. Evaluation of extraction and purification methods for obtaining PCR-amplifiable DNA from compost for microbial community analysis. *Journal of microbiological methods*, **49**(3), 255–264.
- Lane, C. 2010. *Trichoderma green mould-diagnostic assays for improved disease control*. Tech. rept. Horticultural Development Company.
- Largeteau, M.L., Iapicco, R., Savoie, J.-M., & Olivier, J.-M. 2000a. Green mould disease in France: *Trichoderma harzianum* Th2 and other species causing damage on mushroom farms. *Mushroom Science XV: Science and Cultivation of Edible Fungi*, **15**(2), 625–632.
- Largeteau, M.L., Savoie, J.-M., & Olivier, J.-M. 2000b. Interactions between the pathogen *Trichoderma harzianum* Th2 and *Agaricus bisporus* in mushroom compost. *Mycologia*, **92**(2), 233–240.
- Largeteau, M.L., Latapy, C., Minvielle, N., Regnault-Roger, C., & Savoie, J.-M. 2010. Expression of phenol oxidase and heat-shock genes during the development of *Agaricus bisporus* fruiting bodies, healthy and infected by *Lecanicillium fungicola*. *Applied Microbiology and Biotechnology*, **85**(5), 1499–507.
- Lemmers, Geert. 2010. *Trichoderma* in Bulk Phase III (Part 1). *Mushroom Business*, **40**, 10–13.
- Lew, R.R. 2011. How does a hypha grow? The biophysics of pressurized growth in fungi. *Nature reviews. Microbiology*, **9**(7), 509–18.
- Li, B., Fu, Y., Jiang, D., Xie, J., Cheng, J., Li, G., Hamid, M.I., & Yi, X. 2010. Cyclic GMP as a second messenger in the nitric oxide-mediated conidia-

- tion of the mycoparasite *Coniothyrium minitans*. *Applied and Environmental Microbiology*, **76**(9), 2830–6.
- López-Mondéjar, R., Antón, A., Raidl, S., Ros, M., & Pascual, J.A. 2010. Quantification of the biocontrol agent *Trichoderma harzianum* with real-time Taq-Man PCR and its potential extrapolation to the hyphal biomass. *Bioresource Technology*, **101**(8), 2888–2891.
- Lu, M., Poulsen, S.K., Lu, P.S., Jensen, D.F., & Thrane, U. 2000. Identification of *Trichoderma* strains from building materials by ITS1 ribotyping, UP-PCR fingerprinting and UP-PCR cross hybridization. *FEMS Microbiology Letters*, **185**, 129–134.
- Ma, Z., & Michailides, T. 2007. Approaches for eliminating PCR inhibitors and designing PCR primers for the detection of phytopathogenic fungi. *Crop Protection*, **26**(2), 145–161.
- Mach, R.L., Peterbauer, C.K., Payer, K., Jaksits, S., Woo, S.L., Zeilinger, S., Kullnig, C.M., Lorito, M., & Kubicek, C.P. 1999. Expression of two major chitinase genes of *Trichoderma atroviride* (*T. harzianum* P1) is triggered by different regulatory signals. *Applied and Environmental Microbiology*, **65**(5), 1858–1863.
- Maheshwari, R., Bharadwaj, G., & Bhat, M.K. 2000. Thermophilic Fungi : Their Physiology and Enzymes. *Society*, **64**(3).
- Maniratanachote, R., Minami, K., Katoh, M., Nakajima, M., & Yokoi, T. 2006. Dephosphorylation of ribosomal protein P0 in response to troglitazone-induced cytotoxicity. *Toxicology Letters*, **166**(3), 189–99.
- Marra, R., Ambrosino, P., Carbone, V., Vinale, F., Woo, S.L., Ruocco, M., Ciliento, R., Lanzuise, S., Ferraioli, S., Soriente, I., Gigante, S., Turrà, D., Fogliano, V., Scala, F., & Lorito, M. 2006. Study of the three-way interaction between *Trichoderma atroviride*, plant and fungal pathogens by using a proteomic approach. *Current Genetics*, **50**(5), 307–21.

- Martin, G.R. 2008. Phase 1 issues today: a composter's perspective. *Pages 858–866 of: Science and cultivation of edible and medicinal fungi: Mushroom Science XVII.*
- Martinez, D., Berka, R.M., Henrissat, B., Saloheimo, M., Arvas, M., Baker, S.E., Chapman, J., Chertkov, O., Coutinho, P.M., Cullen, D., Danchin, E.G.J., Grigoriev, I.V., Harris, P., Jackson, M., Kubicek, C.P., Han, C.S., Ho, I., Larrondo, L.F., de Leon, A.L., Magnuson, J.K., Merino, S., Misra, M., Nelson, B., Putnam, N., Robbertse, B., Salamov, A.A., Schmoll, M., Terry, A., Thayer, N., Westerholm-Parvinen, A., Schoch, C.L., Yao, J., Barabote, R., Barbote, R., Nelson, M.A., Detter, C., Bruce, D., Kuske, C.R., Xie, G., Richardson, P., Rokhsar, D.S., Lucas, S.M., Rubin, E.M., Dunn-Coleman, N., Ward, M., & Brettin, T.S. 2008. Genome sequencing and analysis of the biomass-degrading fungus *Trichoderma reesei* (syn. *Hypocrea jecorina*). *Nature biotechnology*, **26**(5), 553–560.
- Mathesius, U. 2009. Comparative proteomic studies of root-microbe interactions. *Journal of Proteomics*, **72**(3), 353–66.
- Meincke, R., Weinert, N., Radl, V., Schloter, M., Smalla, K., & Berg, G. 2010. Development of a molecular approach to describe the composition of *Trichoderma* communities. *Journal of Microbiological Methods*, **80**(1), 63–69.
- Minkinen, P. 2004. Practical applications of sampling theory. *Chemometrics and Intelligent Laboratory Systems*, **74**(1), 85–94.
- M.M., Bradford. 1976. A rapid and sensitive method for the quantitation of microgram quantities of protein utilizing the principle of protein-dye binding. *Analytical Biochemistry*, **72**(12), 248 – 254.
- Montero-Barrientos, M., Hermosa, R., Cardoza, R.E., Gutiérrez, S., & Monte, E. 2011. Functional analysis of the *Trichoderma harzianum* nox1 gene, encoding an NADPH oxidase, relates production of reactive oxygen species to specific biocontrol activity against *Pythium ultimum*. *Applied and environmental microbiology*, **77**(9), 3009–16.

- Morris, E., Harrington, O., Doyle, O.P.E., & Clancy, K.J.C. 2000. Green mould disease - The study of survival and dispersal characteristics of the weed mould *Trichoderma*, in the Irish mushroom industry. *Pages 645–652 of: Mushroom Science XV: Science and Cultivation of Edible Fungi.*
- Muñoz, C., Guillen, F., Martínez, A. T., & Martínez, M.J. 1997. Laccase isoenzymes of *Pleurotus eryngii* : characterization , catalytic properties , and participation in activation of molecular oxygen and Mn²⁺ + oxidation. *Applied and Environmental Microbiology*, **63**(6), 2166–2174.
- Muñoz, F. García-gil D. 2007. Free radical generation using the activation of hemolymph prepared from the homopteran *Dactylopius coccus*. *Archives of Insect Biochemistry and Physiology*, **28**(May), 20–28.
- Mukherjee, P.K., Horwitz, B.A., & Kenerley, C.M. 2012. Secondary metabolism in *Trichoderma*—a genomic perspective. *Microbiology (Reading, England)*, **158**(1), 35–45.
- Mullis, K., Faloona, F., Scharf, S., Saiki, R., Horn, G., & Erlich, H. 1986. Specific enzymatic amplification of DNA *in vitro*: the polymerase chain reaction. *Cold Spring Harbor Symposia on Quantitative Biology*, **51**(1), 263–273.
- Mumpuni, A., Sharma, H.S.S., & Brown, A.E. 1998. Effect of metabolites produced by *Trichoderma harzianum* biotypes and *Agaricus bisporus* on their respective growth radii in culture. *Applied and Environmental Microbiology*, **64**(12), 5053–6.
- Muthumeenakshi, S., Mills, P.R., Brown, A.E., & Seaby, D.A. 1994. Intraspecific molecular variation among *Trichoderma harzianum* isolates colonizing mushroom compost in the British Isles. *Microbiology (Reading, England)*, **140**(4), 769–777.
- Muthumeenakshi, S., Brown, A.E., & Mills, P.R. 1998. Genetic comparison of the aggressive weed mould strains of *Trichoderma harzianum* from mushroom compost in North America and the British Isles. *Plant Pathology*, **102**(4), 385–390.

- Nampoothiri, K.M., Baiju, T.V., Sandhya, C., Sabu, A., Szakacs, G., & Pandey, A. 2004. Process optimization for antifungal chitinase production by *Trichoderma harzianum*. *Process Biochemistry*, **39**(11), 1583–1590.
- Nguyen, M.H., Husain, S. and Clancy, C.J., Peacock, J.E., Hung, C.-C., Kontoyiannis, D.P., Morris, A.J., Heath, C.H., Wagener, M., & Yu, V.L. 2010. Outcomes of central nervous system cryptococcosis vary with host immune function: results from a multi-center, prospective study. *The Journal of Infection*, **61**(5), 419–426.
- Nielsen, K.F., & Smedsgaard, J. 2003. Fungal metabolite screening : database of 474 mycotoxins and fungal metabolites for dereplication by standardised liquid chromatography UV mass spectrometry methodology. *Journal of Chromatography A*, **1002**, 111–136.
- Nielsen, N.-P.V., Carstensen, J.M., & Smedsgaard, J. 1998. Aligning of single and multiple wavelength chromatographic profiles for chemometric data analysis using correlation optimised warping. *Journal of Chromatography A*, **805**(1-2), 17–35.
- Nikoh, N., Hayase, N., Iwabe, N., Kuma, K., & Miyata, T. 1994. Phylogenetic relationship of the kingdoms Animalia, Plantae, and Fungi, inferred from 23 different protein species. *Molecular Biology and Evolution*, **11**(5), 762–768.
- Noble, R. and Dobrovin-Pennington, A., & Spurdens, D. 2000. *M 35: Determining the causes of mushroom water stress symptoms*. Tech. rept. Horticultural Development Company.
- Noble, R., & Gaze, R.H. 1994. Controlled environment composting for mushroom cultivation: substrates based on wheat and barley straw and deep litter poultry manure. *The Journal of Agricultural Science*, **123**, 71–79.
- Noble, R., & Gaze, R.H. 1996. Preparation of mushroom (*Agaricus bisporus*) composts in controlled environments: Factors influencing compost bulk density and productivity. *International Biodeterioration & Biodegradation*, **37**(1-2), 93–100.

- Noble, R., Fermor, T.R., Lincoln, S., Evered, C., Mead, A., & Li, R. 2003. Primordia initiation of mushroom (*Agaricus bisporus*) strains on axenic casing materials. *Mycologia*, **95**(4), 620–629.
- Ospina-Giraldo, M.D., Royse, D.J., Thon, M.R., Chen, X., & Romaine, C.P. 1998. Phylogenetic relationships of *Trichoderma harzianum* causing mushroom green mold in Europe and North America to other species of *Trichoderma* sources from world-wide. *Mycologia*, **90**(1), 76–81.
- Ospina-Giraldo, M.D., Royse, D.J., Chen, X., & Romaine, C.P. 1999. Molecular phylogenetic analyses of biological control strains of *Trichoderma harzianum* and other biotypes of *Trichoderma* spp. associated with mushroom green mold. *Phytopathology*, **89**(4), 308–13.
- Otieno, W., Jeger, M., & Termorshuizen, A. 2003. Effect of infesting soil with *Trichoderma harzianum* and amendment with coffee pulp on survival of *Armillaria*. *Biological Control*, **26**(3), 293–301.
- Parati, F., Altieri, R., Esposito, A., Lobianco, A., Pepi, M., Montesi, L., & Nair, T. 2011. Validation of thermal composting process using olive mill solid waste for industrial scale cultivation of *Agaricus bisporus*. *International Biodeterioration & Biodegradation*, **65**(1), 160–163.
- Paredes, C., & Medina, E. 2009. Characterization of the Different Organic Matter Fractions of Spent Mushroom Substrate. *Communications in Soil Science and Plant Analysis*, **40**, 150–161.
- Pasini, E.M., Lutz, H.U., Mann, M., & Thomas, A.W. 2010. Red blood cell (RBC) membrane proteomics—Part II: Comparative proteomics and RBC patho-physiology. *Journal of Proteomics*, **73**(3), 421–35.
- Patyshakuliyeva, A., & De Vries, R.P. 2011. Biodegradation of carbohydrates during the formation of *Agaricus bisporus* compost. *Pages 197–202 of: Proceedings of the 7th International Conference on Mushroom Biology and Mushroom Products*, vol. 1.

- Pecchia, J.A., Beyer, D.M., & Wuest, P.J. 2002. The effect of poultry manure based formulations on odor generation during phase I mushroom composting. *Compost Science and Utilisation*, **10**(3), 186–196.
- Pegg, A.E. 1986. Recent advances in the biochemistry of polyamines in eukaryotes. *The Biochemical Journal*, **234**(2), 249–262.
- Perrone, S.T., McDonald, K.L., Sutherland, M.W., & Guest, D.I. 2003. Superoxide release is necessary for phytoalexin accumulation in *Nicotiana tabacum* cells during the expression of cultivar-race and non-host resistance towards *Phytophthora* spp. *Physiological and Molecular Plant Pathology*, **62**(3), 127–135.
- Peskin, A.V. 1997. Cu,Zn-superoxide dismutase gene dosage and cell resistance to oxidative stress: a review. *Bioscience Reports*, **17**(1), 85–9.
- Petersen, L., Dahl, C.K., & Esbensen, K.H. 2004. Representative mass reduction in sampling a critical survey of techniques and hardware. *Chemometrics and Intelligent Laboratory Systems*, **74**(1), 95–114.
- Petersen, L., Minkkinen, P., & Esbensen, K.H. 2005. Representative sampling for reliable data analysis: Theory of Sampling. *Chemometrics and Intelligent Laboratory Systems*, **77**(1-2), 261–277.
- Philippoussis, A., & Diamantopoulou, P. 2011. Agro-food industry and agricultural residues conversion into high value products by mushroom cultivation. *Pages 339–351 of: Proceedings of the 7th International Conference on Mushroom Biology and Mushroom Products*, vol. 1.
- Polizzi, V., Adams, A.N., Picco, A.M., Adriaens, E., Lenoir, J., Van Peteghem, C., De Saeger, S., & De Kimpe, N. 2011. Influence of environmental conditions on production of volatiles by *Trichoderma atroviride* in relation with the sick building syndrome. *Building and Environment*, **46**(4), 945–954.
- Qin, W.M., & Lan, W.Z. 2004. Fungal elicitor-induced cell death in *Taxus chinensis* suspension cells is mediated by ethylene and polyamines. *Plant Science*, **166**(4), 989–995.

- Rao, J.R., Watabe, M., Stewart, T.A., Millar, B.C., & Moore, J.E. 2007. Pelleted organo-mineral fertilisers from composted pig slurry solids, animal wastes and spent mushroom compost for amenity grasslands. *Waste management (New York, N.Y.)*, **27**(9), 1117–28.
- Reales-Calderón, J.A., Martínez-Solano, L., Martínez-Gomariz, M., Nombela, C., Molero, G., & Gil, C. 2012. Sub-proteomic study on macrophage response to *Candida albicans* unravels new proteins involved in the host defense against the fungus. *Journal of Proteomics*, **75**(15), 4734–4746.
- Regnier, T., Combrick, S., Paley, K., & Beyer, D. 2012. Application regime for disease control using thyme oil. *Pages 384–389 of: Proceedings of the 18th international congress on mushroom biology an mushroom science: Mushroom Science XVIII.*
- Reuter, T., Xu, W., Alexander, T.W., Stanford, K., Xu, Y., & McAllister, T.A. 2009. Purification of polymerase chain reaction (PCR)-amplifiable DNA from compost piles containing bovine mortalities. *Bioresource technology*, **100**(13), 3343–3349.
- Rich, B.E., & Steitz, J.A. 1987. Human acidic ribosomal phosphoproteins PO, P1, and P2: analysis of cDNA clones , in vitro synthesis, and assembly. *Molecular and Cellular Biology*, **7**(11), 4065–4074.
- Rifai, M.A. 1969. A revision of the genus *Trichoderma*. *Mycology Papers*, **116**, 1–56.
- Rinker, D.L. 1997. Sensitivity of spawn-run compost or casing to green mould infection. *Mushroom World*.
- Rinker, D.L., & Alm, G. 2000. Management of green mould disease in Canada. *Mushroom Science XV: Science and Cultivation of Edible Fungi*.
- Rinker, D.L., & Alm, G. 2008. Management of casing *Trichoderma* using fungicides. *Pages 496–509 of: Science and cultivation of edible and medicinal fungi: Mushroom Science XVII.*

- Robson, G.D., Wiebe, M.G., & Trinci, A.P. 1991. Exogenous cAMP and cGMP modulate branching in *Fusarium graminearum*. *Journal of General Microbiology*, **137**(4), 963–9.
- Romaine, C.P., Royse, D.J., & Schlaghauser, C. 2008. Emergence of benzimidazole-resistant green mould, *Trichoderma aggressivum*, on cultivated *Agaricus bisporus* in North America. *Pages 510–523 of: Science and cultivation of edible and medicinal fungi: Mushroom Science XVII*.
- Royse, D.J., & Chalupa, W. 2009. Effects of spawn, supplement and phase II compost additions and time of re-casing second break compost on mushroom (*Agaricus bisporus*) yield and biological efficiency. *Bioresource technology*, **100**(21), 5277–82.
- Royse, D.J., Boomer, K., Du, Y., Handcock, M., Coles, P.S., & Romaine, C.P. 1999. Spatial distribution of green mold foci in 30 commercial mushroom crops. *Plant Disease*, **83**(1), 71–76.
- Rubio, M.B., Hermosa, R., Reino, J.L., Collado, I.G., & Monte, E. 2009. Thectf1 transcription factor of *Trichoderma harzianum* is involved in 6-pentyl-2H-pyran-2-one production and antifungal activity. *Fungal genetics and biology : FG & B*, **46**(1), 17–27.
- Samuels, G.J. 1996. *Trichoderma*: a review of biology and systematics of the genus. *Mycological Research*, **100**(8), 923–935.
- Samuels, G.J., Dodd, S.L., Gams, W., Castlebury, L.A., & Petrini, O. 2002. *Trichoderma* species associated with the green mold epidemic of commercially grown *Agaricus bisporus*. *Mycologia*, **94**(1), 146–170.
- Samuels, G.J., Chaverri, P., Farr, D.F., & McCray, E.B. 2012. *Trichoderma* Online. *Systematic Mycology and Microbiology Laboratory, ARS, USDA*, Retrieved October 9.
- Sánchez, C. 2004. Modern aspects of mushroom culture technology. *Applied microbiology and biotechnology*, **64**(6), 756–62.

- Sanchez, J.E., Mejia, L., & Royse, D.J. 2008. Pangola grass colonized with *Scytalidium thermophilum* for production of *Agaricus bisporus*. *Bioresource technology*, **99**(3), 655–62.
- Santos, C., & Ballesta, J.P.G. 2002. Role of the ribosomal stalk components in the resistance of *Aspergillus fumigatus* to the sordarin antifungals. *Molecular Microbiology*, **43**(1), 227–37.
- Santos, C., Remacha, M., Ballesta, G., & Ballesta, J.P.G. 2004. Ribosomal P0 protein domain involved in selectivity of antifungal sordarin derivatives. *Antimicrobial Agents and Chemotherapy*, **48**(8), 2930–2936.
- Sanz, L., Chamorro, M.I., Rey, M., Bele, M., Llobell, A., Monte, E., & Gonza, F.J. 2005. Proteomic analysis of secreted proteins from *Trichoderma harzianum*. Identification of a fungal cell wall-induced aspartic protease. *Fungal Genetics and Biology*, **42**, 924–934.
- Savoie, J.-M., & Mata, G. 1998. Extracellular laccase production during hyphal interactions between *Trichoderma* sp. and Shiitake, *Lentinula edodes*. *Applied and Environmental Microbiology*, **49**, 589–593.
- Savoie, J.-M., & Mata, G. 2003. *Trichoderma harzianum* metabolites pre-adapt mushrooms to *Trichoderma aggressivum* antagonism. *Mycologia*, **95**(2), 191–199.
- Savoie, J.-M., Iapicco, R., & Largeteau-Mamoun, M. 2001a. Factors influencing the competitive saprophytic ability of *Trichoderma harzianum* Th2 in mushroom (*Agaricus bisporus*) compost. *Mycological Research*, **105**(11), 1348–1356.
- Savoie, J.-M., Mata, G., & Mamoun, M. 2001b. Variability in brown line formation and extracellular laccase production during interaction between white-rot basidiomycetes and *Trichoderma harzianum* biotype Th2. *Mycologia*, **93**(2), 243–248.
- Savoie, J.-M., Védie, R., Blanc, F., Minvielle, N., Rousseau, T., & Delegnes, J.-P. 2011. Biomethane digestate from horse manure, a new waste usable in compost for growing the button mushroom *Agaricus bisporus*? *Pages 179–181*

- of: *Proceedings of the 7th International Conference on Mushroom Biology and Mushroom Products*, vol. 2.
- Schickler, H., C.B., Danin-Gehald, Haran, S., & Chet, I. 1998. Electrophoretic characterization of chitinases as a tool for the identification of *Trichoderma harzianum* strains. *Mycological Research*, **102**(3), 373–377.
- Scrase, R. 1995. Cultivating mushrooms From pure culture to spawn production. *Mycologist*, **9**(2), 53–56.
- Seaby, D.A. 1987. Infection of mushroom compost by *Trichoderma* species. *Mushroom Journal*, **179**, 355–361.
- Seaby, D.A. 1989. Further observations on *Trichoderma* species. *Mushroom Journal*, **197**, 147–151.
- Seaby, D.A. 1996a. Differentiation of *Trichoderma* taxa associated with mushroom production. *Plant Pathology*, **45**(5), 905–912.
- Seaby, D.A. 1996b. Investigation of the epidemiology of green mould of mushroom (*Agaricus bisporus*) compost caused by *Trichoderma harzianum*. *Plant Pathology*, **45**(5), 913–923.
- Seidl, V., Marchetti, M., Schandl, R., Allmaier, G., & Kubicek, C.P. 2006. Epl1, the major secreted protein of *Hypocrea atroviridis* on glucose, is a member of a strongly conserved protein family comprising plant defense response elicitors. *The FEBS Journal*, **273**(18), 4346–59.
- Seidl, V., Song, L., Lindquist, E., Gruber, S., Koptchinskiy, A., Zeilinger, S., Schmoll, M., Martínez, P., Sun, J., Grigoriev, I., Herrera-Estrella, A., Baker, S.E., & Kubicek, C.P. 2009. Transcriptomic response of the mycoparasitic fungus *Trichoderma atroviride* to the presence of a fungal prey. *BMC genomics*, **10**(Jan.), 567.
- Seneviratne, C.J., Wang, Y., Jin, L., Abiko, Y., & Samaranyake, L.P. 2010. Proteomics of drug resistance in *Candida glabrata* biofilms. *Proteomics*, **10**(7), 1444–54.

- Shamshad, A., Clift, A.D., & Mansfield, S. 2009. The effect of tibia morphology on vector competency of mushroom sciarid flies. *Journal of Applied Entomology*, **133**(6), 484–490.
- Sharma, H.S.S and, Cunha-B., Kilpatrick, M., Lyons, G., Wichers, H., & Hoozee, J. 2008. Quality evaluation of gamma-irradiated cereal grains for spawn production. *Pages 413–436 of: Science and cultivation of edible and medicinal fungi: Mushroom Science XVII.*
- Sharma, H.S.S., Kilpatrick, M., Lyons, G., & Burns, L. 1999. Colonisation of phase II compost by biotypes of *Trichoderma harzianum* and their effect on mushroom yield and quality. *Applied Microbiology and Biotechnology*, **51**, 572–578.
- Sharma, H.S.S., Lyons, G., & Chambers, J. 2000. Comparison of the changes in mushroom (*Agaricus bisporus*) compost during windrow and bunker stages of phase I and II. *Annals of Applied Biology*, **136**, 59–68.
- Shevchenko, A., Tomas, H., Havlis, J., Olsen, J.V., & Mann, M. 2006. In-gel digestion for mass spectrometric characterization of proteins and proteomes. *Nature Protocols*, **1**(6), 2856–60.
- Silar, P. 2005. Peroxide accumulation and cell death in filamentous fungi induced by contact with a contestant. *Mycological Research*, **109**(2), 137–149.
- Singh, A.D., Abdullah, N., & Vikineswary, S. 2003. Optimization of extraction of bulk enzymes from spent mushroom compost. *Journal of Chemical Technology & Biotechnology*, **78**(7), 743–752.
- Singh, S.K., Vijay, B., Mediratta, V., Ahlawat, O.P., & Kamal, S. 2005. Molecular characterization of *Humicola grisea* isolates associated with *Agaricus bisporus* compost. *Current Science*, **59**(10), 1745–1748.
- Slot, J.C., & Hibbett, D.S. 2007. Horizontal transfer of a nitrate assimilation gene cluster and ecological transitions in fungi: a phylogenetic study. *PloS one*, **2**(10), e1097.

- Smedsgaard, J. 1997. Micro-scale extraction procedure for standardized screening of fungal metabolite production in cultures. *Journal of Chromatography A*, **760**(2), 264–70.
- Sobieralski, K., Siwulski, M., Fruyska-Józwiak, D., Błaszczuk, L., Sas-Golak, I., & Jasiska, A. 2010. Impact of infections with two *Trichoderma aggressivum* f. *europaeum* isolates on the yielding of some wild strains of *Agaricus bisporus* (Lange) Imbach. *Journal of Plant Protection Research*, **50**(4), 501–504.
- Sonnenberg, A.S.M., Baars, J.J.P., Hendrickx, P.M., Lavrijssen, B., Gao, W., Weijn, A., & Mes, J.J. 2011. Breeding and strain protection in the button mushroom *Agaricus bisporus*. *Pages 7–15 of: Proceedings of the 7th International Conference on Mushroom Biology and Mushroom Products*, vol. 1.
- Stajich, J.E., Berbee, M.L., Blackwell, M., Hibbett, D.S., Timothy, Y., Spatafora, J.W., & Taylor, J.W. 2009. The Fungi. *Current Biology*, **19**(18), 840–845.
- Staniaszek, S., Szajko, K., Uliński, Z., Szczech, M., & Marczewski, W. 2010. BseGI restriction of the polymerase chain reaction amplicon Th444 is required to distinguish biotypes of *Trichoderma aggressivum* causing serious losses in mushroom (*Agaricus bisporus*) production. *HortScience*, **45**(12), 1910–1911.
- Staunton, L. 1987. *Trichoderma* green mould in mushroom compost. *Mushroom Journal*, **179**, 362–363.
- Staunton, L., & Dunne, R. 1997. *Integrated disease and pest control in Irish mushroom tunnels*. Tech. rept. Teagasc.
- Stoknes, K., Høiland, K., Norgaard, E., & Hammer, P.J. 2008. From food to waste to food - a high yield of mushrooms from food waste compost. *Pages 272–285 of: Science and cultivation of edible and medicinal fungi: Mushroom Science XVII*.
- Straatsma, G., Gerrits, J.P.G., Gerrits, T.M., op den Camp, H.J.M., & van Griensven, L.J.L.D. 1991. Growth kinetics of *Agaricus bisporus* mycelium on solid substrate (mushroom compost). *Journal of General Microbiology*, **137**(7), 1471–1477.

- Taylor, J.W., Turner, E., Townsend, J.P., Dettman, J.R., & Jacobson, D. 2006. Eukaryotic microbes, species recognition and the geographic limits of species: examples from the kingdom Fungi. *Philosophical transactions of the Royal Society of London. Series B, Biological sciences*, **361**(1475), 1947–1963.
- Tebbe, C.C., & Vahjen, W. 1993. Interference of humic acids and DNA extracted directly from soil in detection and transformation of recombinant DNA from bacteria and a yeast. *Applied and Environmental Microbiology*, **59**(8), 2659–2665.
- ten Have, R., Wijngaard, H., Ariës-Kronenburg, N. A. E., Straatsma, G., & Schaap, P. J. 2003. Lignin degradation by *Agaricus bisporus* accounts for a 30% increase in bioavailable holocellulose during cultivation on compost. *Journal of agricultural and food chemistry*, **51**(8), 2242–5.
- Thornton, C.R., & Dewey, F.M. 1996. Detection of phialoconidia of *Trichoderma harzianum* in peat-bran by monoclonal antibody-based enzyme-linked immunosorbent assay. *Mycological Research*, **100**(2), 217–222.
- Thrane, U., Poulsen, S.B., Nirenberg, H.I., & Lieckfeldt, E. 2001. Identification of *Trichoderma* strains by image analysis of HPLC chromatograms. *FEMS Microbiology Letters*, **203**(2), 249–255.
- Thy, P., Esbensen, K.H., & Jenkins, B.M. 2009. On representative sampling and reliable chemical characterization in thermal biomass conversion studies. *Biomass and Bioenergy*, **33**(11), 1513–1519.
- Tkachenko, A.G., & Fedotova, M.V. 2007. Dependence of protective functions of *Escherichia coli* polyamines on strength of stress caused by superoxide radicals. *Biochemistry (Moscow)*, **72**(1), 109–116.
- Tønning, E., Nørgaard, L., Engelsen, S.B., Pedersen, L., & Esbensen, K.H. 2006. Protein heterogeneity in wheat lots using single-seed NIT A Theory of Sampling (TOS) breakdown of all sampling and analytical errors. *Chemometrics and Intelligent Laboratory Systems*, **84**(1-2), 142–152.

- Tornberg, K., & Olsson, S. 2002. Detection of hydroxyl radicals produced by wood-decomposing fungi. *FEMS Microbiology Ecology*, **40**(1), 13–20.
- Tsujiyama, S., & Minami, M. 2005. Production of phenol-oxidizing enzymes in the interaction between white-rot fungi. *Mycoscience*, **46**(4), 268–271.
- Unger, C., Kleta, S., Jandl, G., & Tiedemann, A. 2005. Suppression of the defence-related oxidative burst in bean leaf tissue and bean suspension cells by the necrotrophic pathogen *Botrytis cinerea*. *Journal of Phytopathology*, **26**, 15–26.
- Van Griensven, L.J.L.D., & Van Roestel, A.J.J. 2004. The cultivation of the button mushroom, *Agaricus bisporus*, in The Netherlands : a successful industry. *Revista Mexicana de Micologia*, **19**(12), 95–102.
- Van Griensven, L.J.L.D., & Vogels, G. D. 1990. Biomass and biological activity during the production of compost used as a substrate in mushroom cultivation. *Applied and environmental microbiology*, **56**(10), 3029–3034.
- Verma, M., Brar, S.K., Tyagi, R.D., Surampalli, R.Y., & Valéro, J.R. 2007. Antagonistic fungi, *Trichoderma* spp.: Panoply of biological control. *Biochemical Engineering Journal*, **37**(1), 1–20.
- Vernooij, E.M.M. 2008. Casing, 'the skin of the substrate': preparation and management of the casing layer. *Pages 875–898 of: Science and cultivation of edible and medicinal fungi: Mushroom Science XVII*.
- Veuthey, A.-L., & Bittar, G. 1998. Phylogenetic relationships of fungi, plantae, and animalia inferred from homologous comparison of ribosomal proteins. *Journal of Molecular Evolution*, **47**(1), 81–92.
- Watabe, M., Rao, J.R., Xu, J., Millar, B.C., Ward, R.F., & Moore, J.E. 2004. Identification of novel eubacteria from spent mushroom compost (SMC) waste by DNA sequence typing: ecological considerations of disposal on agricultural land. *Waste management (New York, N.Y.)*, **24**(1), 81–6.
- Wenzel, M., & Bandow, J.E. 2011. Proteomic signatures in antibiotic research. *Proteomics*, **11**(15), 3256–68.

-
- Whittaker, R.H. 1969. New Concepts of Kingdoms of Organisms. *Science*, **163**(3863), 150–160.
- Williams, J., Clarkson, J.M., Mills, P.R., & Cooper, R.M. 2003a. A selective medium for quantitative reisolation of *Trichoderma harzianum* from *Agaricus bisporus* compost. *Applied and Environmental Microbiology*, **69**(7), 4190–4191.
- Williams, J., Clarkson, J.M., Mills, P.R., & Cooper, R.M. 2003b. Saprotrophic and mycoparasitic components of aggressiveness of *Trichoderma harzianum* groups toward the commercial mushroom *Agaricus bisporus*. *Applied and Environmental Microbiology*, **69**(7), 4192–4199.
- Zarenejad, F., Yakhchali, B., & Rasooli, I. 2012. Evaluation of indigenous potent mushroom growth promoting bacteria (MGPB) on *Agaricus bisporus* production. *World journal of microbiology & biotechnology*, **28**(1), 99–104.
- Zipper, H. 2003. Mechanisms underlying the impact of humic acids on DNA quantification by SYBR Green I and consequences for the analysis of soils and aquatic sediments. *Nucleic Acids Research*, **31**(7), 39e–39.